



Designation: D 4812 – 05

Standard Test Method for Unnotched Cantilever Beam Impact Resistance of Plastics¹

This standard is issued under the fixed designation D 4812; the number immediately following the designation indicates the year of original adoption or, in the case of revision, the year of last revision. A number in parentheses indicates the year of last approval. A superscript epsilon (ϵ) indicates an editorial change since the last revision or reapproval.

1. Scope*

1.1 This test method covers the determination of the resistance of plastics to breakage by flexural shock, as indicated by the energy extracted from standardized pendulum-type hammers, mounted in standardized machines, in breaking standard specimens with one pendulum swing. The result of this test method is reported as energy absorbed per unit of specimen width.

NOTE 1—The pendulum-type test instruments have been standardized in that they must comply with certain requirements, including a fixed height of hammer fall that results in a substantially fixed velocity of the hammer at the moment of impact. Pendulums of different initial energies (produced by varying their effective weights) are recommended for use with specimens of different impact strengths. Moreover, manufacturers of the equipment are permitted to use different lengths and constructions of pendulums (with resulting possible differences in pendulum rigidities (see Section 5), and other differences in machine design).

1.2 The values stated in SI units are to be regarded as standard. The values given in brackets are for information only.

1.3 *This standard does not purport to address all of the safety concerns, if any, associated with its use. It is the responsibility of the user of this standard to establish appropriate safety and health practices and determine the applicability of regulatory limitations prior to use.*

NOTE 2—This standard and ISO 180, Method 1U, are similar in content but are not technically equivalent.

2. Referenced Documents

2.1 *ASTM Standards:*²

D 256 Test Methods for Impact Resistance of Plastics and Electrical Insulating Materials

D 618 Practice for Conditioning Plastics for Testing

D 883 Terminology Relating to Plastics

D 5947 Test Methods for Physical Dimensions of Solid Plastic Specimens

E 691 Practice for Conducting an Interlaboratory Study to

Determine the Precision of a Test Method

3. Terminology

3.1 *Definitions*—Definitions used in this test method are in accordance with Terminology D 883.

4. Summary of Test Method

4.1 This test method differs from others of similar character in that unnotched test specimens are used (see Test Methods D 256 for procedures using notched test specimens). The lack of a notch makes this test method especially useful for reinforced materials where a notch may mask the effects of orientation. It may also be used with other filled or unreinforced materials where a stress-concentrating notch is not desired. It is not valid for materials that twist when subjected to this test.

5. Significance and Use

5.1 The pendulum-impact test indicates the energy to break standard test specimens of specified size under stipulated conditions of specimen mounting and pendulum velocity at impact.

5.2 The energy lost by the pendulum during the breakage of the specimen is the sum of the energies required to produce the following results:

5.2.1 To initiate fracture of the specimen,

5.2.2 To propagate the fracture across the specimen,

5.2.3 To throw the free end (or pieces) of the broken specimen (toss correction),

5.2.4 To bend the specimen,

5.2.5 To produce vibration in the pendulum arm,

5.2.6 To produce vibration or horizontal movement of the machine frame or base,

5.2.7 To overcome friction in the pendulum bearing and in the indicating mechanism, and to overcome windage (pendulum air drag),

5.2.8 To indent or deform plastically the specimen at the line of impact, and

5.2.9 To overcome the friction caused by the rubbing of the striking nose (or other part of the pendulum) over the face of the bent specimen.

5.3 For relatively brittle materials for which fracture propagation energy is small in comparison with the fracture initiation energy, the indicated impact energy absorbed is, for all

¹ This test method is under the jurisdiction of ASTM Committee D20 on Plastics and is the direct responsibility of Subcommittee D20.10 on Mechanical Properties.

Current edition approved Nov. 1, 2005. Published December 2005. Originally approved in 1988. Last previous edition approved in 1999 as D 4812 - 99.

² For referenced ASTM standards, visit the ASTM website, www.astm.org, or contact ASTM Customer Service at service@astm.org. For *Annual Book of ASTM Standards* volume information, refer to the standard's Document Summary page on the ASTM website.

*A Summary of Changes section appears at the end of this standard.

practical purposes, the sum of items given in 5.2.1 and 5.2.3. The toss correction (5.2.3) may represent a very large fraction of the total energy absorbed when testing relatively dense and brittle materials.

5.4 For materials for which the fracture propagation energy (5.2.2) may be large compared to the fracture initiation energy (5.2.1), factors (5.2.2, 5.2.5, and 5.2.9) can become quite significant, even when the specimen is accurately machined and positioned and the machine is in good condition with adequate capacity (Note 3). Bending (5.2.4) and indentation losses (5.2.8) may be appreciable when testing soft materials.

NOTE 3—Although the frame and base of the machine should be sufficiently rigid and massive to handle the energies of tough specimens without motion or excessive vibration, the pendulum arm cannot be made very massive because the greater part of its mass must be concentrated near its center of percussion at the striking nose. Locating the striking nose precisely at the center of percussion reduces vibration of the pendulum arm when used with brittle specimens. However, some losses due to pendulum-arm vibration, the amount varying with the design of the pendulum, will occur with tough specimens even when the striking nose is properly positioned.

5.5 In a well-designed machine of sufficient rigidity and mass the losses due to the items given in 5.2.6 and 5.2.7 should be very small. Vibrational losses (5.2.6) can be quite large when specimens of tough materials are tested in machines of insufficient mass which are not securely fastened to a heavy base.

5.6 This test method requires that the type of failure for each specimen be recorded as one of the three coded categories defined as follows:

5.6.1 C (Complete Break)—A break in which the specimen is separated into two or more pieces.

5.6.2 P (Partial Break)—An incomplete break that has fractured at least 90 % of the depth of the specimen.

5.6.3 NB (Non-Break)—An incomplete break where the fracture extends less than 90 % of the depth of the specimen.

5.6.3.1 For tough materials the pendulum may not have the energy necessary to completely break the extreme outermost fibers and toss the broken piece or pieces. Results obtained from “non-break” specimens shall be considered a departure from standard and shall be reported as “NB” only and a numerical value shall not be reported. Impact values cannot be directly compared for any two materials that experience different types of failure as defined by this code.

5.6.4 Averages reported must likewise be derived from specimens contained within a single failure category. This letter code will be included with the reported impact identifying the types of failure associated with the reported value. If more than one type of failure is observed for a sample material, then the report will indicate the average impact value for each type of failure, followed by the percent of the specimens failing in that manner and identified by the letter code.

5.7 The value of this impact test method lies mainly in the areas of quality control and materials specification. The fact that a material shows twice the energy absorption of another under these conditions of test does not indicate that this same relationship will exist under another set of test conditions. The ranking of materials may even be changed under different testing conditions.

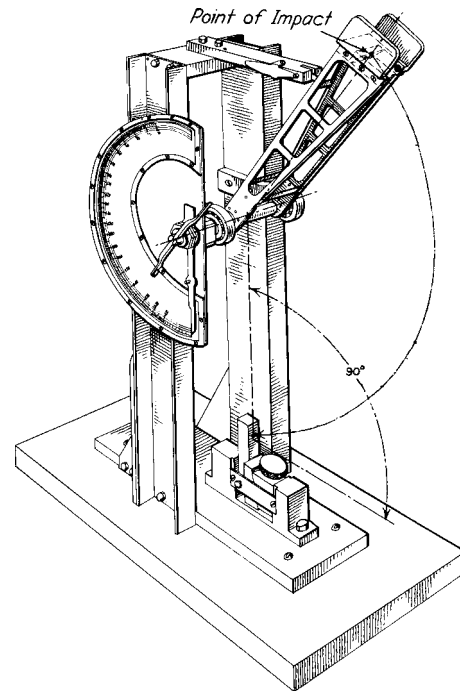

FIG. 1 Cantilever Beam Impact Test Equipment

5.8 Before proceeding with this test method, reference should be made to the specification of the material being tested. Any test specimen preparation, conditioning, dimensions, or testing parameters, or combination thereof, covered in the material specification shall take precedence over those mentioned in this test method except in cases where to do so would conflict with the purpose for conducting testing. If there are no material specifications, then the default conditions apply.

6. Apparatus

6.1 *Impact Machine*, consisting of a massive base on which is mounted a vise for holding the specimen and to which is connected, through a rigid frame and antifriction bearings, one of a number of pendulum-type hammers (or one basic hammer to which extra weights may be attached) having an initial energy suitable for use with the particular specimen to be tested, plus a pendulum holding and releasing mechanism and a mechanism for indicating the breaking energy of the specimen. A jig for positioning the specimen in the vise and graphs or tables to aid in the calculation of the correction for friction and windage should be included. See Fig. 1 for one type of machine that may be used. The type of machine that is depicted can also be used for the testing of notched specimens using Test Methods D 256. Detailed requirements are given in 6.2-6.5. See Appendix X1 for general methods for checking and calibrating the machine. Additional instructions for adjusting a particular machine should be supplied by the manufacturer.

6.2 *Pendulum*, consisting of a single or multimembered arm with a bearing on one end and a head, containing the striking nose, on the other. Although a large proportion of the mass of the pendulum should be concentrated in the head, the arm must be sufficiently rigid to maintain the proper clearances and geometric relationships between the machine parts and the

specimen and to minimize vibrational losses which are always included in the measured impact value.

6.2.1 *Striking Nose (of the Pendulum)*, of hardened steel and cylindrical surface having a radius of curvature of 0.80 ± 0.20 mm [0.031 ± 0.008 in.] with its axis horizontal and perpendicular to the plane of swing of the pendulum.

6.2.1.1 The line of contact of the striking nose shall be located at the center of percussion of the pendulum within ± 2.54 mm [± 0.100 in.] (Note 4). Those portions of the pendulum adjacent to the cylindrical striking edge shall be recessed or inclined at a suitable angle so that there will be no chance for other than this cylindrical surface coming into contact with the specimen during the break.

6.2.2 *Pendulum Holding and Releasing Mechanism*, in a position such that the vertical height of fall of the striking nose shall be 610 ± 2 mm [24.0 ± 0.1 in.]; this will produce a velocity of the striking nose at the moment of impact of approximately 3.46 m [11.35 ft]/s. The mechanism shall be so constructed and operated that it will release the pendulum without imparting acceleration or vibration to it.

6.2.3 The effective length of the pendulum shall be between 0.325 and 0.406 m [12.8 and 16.0 in.] so that the above required elevation of the striking nose may be obtained by raising the pendulum to an angle between 60 and 30° above the horizontal.

NOTE 4—The distance from the axis of support to the center of percussion may be determined experimentally from the period of small amplitude oscillations of the pendulum, as follows:

$$L = (g/4\pi^2)p^2 \quad (1)$$

where:

L = distance from the axis of support to the center of percussion, m [ft].

g = local gravitational acceleration (known to an accuracy of one part in one thousand), m/s^2 [ft/s^2].

π = 3.1416 ($4\pi^2 = 39.4786$), and

p = period, s, of a single complete swing (to and fro) determined from at least 50 consecutive and uninterrupted swings (known to one part in two thousands). The angle of swing shall be less than 5° each side of center.

6.2.4 The machine shall be provided with a basic pendulum capable of delivering an energy of 2.710 ± 0.135 J [2.00 ± 0.10 ft-lbf]. This pendulum shall be used with all specimens that extract less than 85 % of this energy. Heavier pendulums shall be provided for specimens that require more energy to break. These may be separate interchangeable pendulums or one basic pendulum to which extra pairs of equal calibrated weights may be attached rigidly to opposite sides of the pendulum at its center of percussion. It is imperative that the extra weights shall not change the position of the center of percussion of the free-hanging rest point of the pendulum.

6.2.4.1 A range of pendulums having energies from 2.710 to 21.680 J [2 to 16 ft-lbf] has been found to be sufficient for use with most plastic specimens and may be used with most machines. A series of pendulums such that each has twice the energy of the next lighter one will be found convenient. Each pendulum shall have an energy within ± 0.5 % of its nominal capacity.

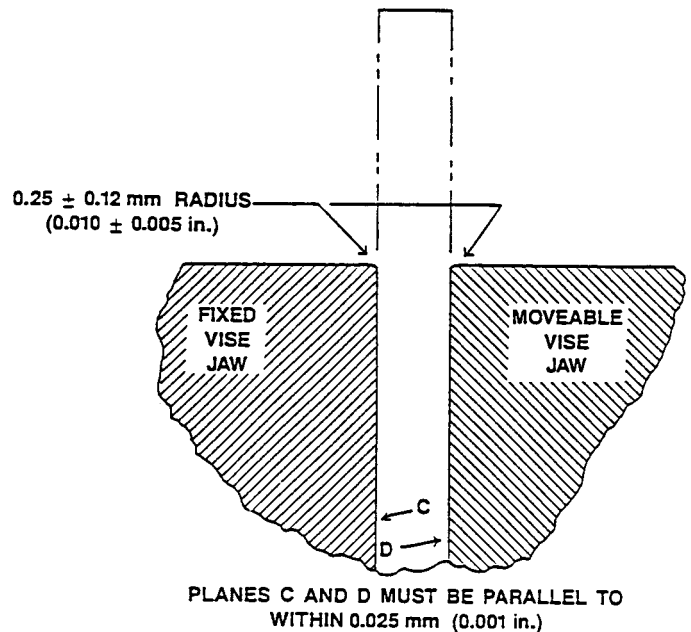

FIG. 2 Diagram Showing Proper Radius for Vise Jaw Edges

6.2.5 When the pendulum is free-hanging, the striking surface shall come within 0.5 % of scale of touching the front face of a standard specimen. During an actual swing this element shall make initial contact with the specimen on a line 22.00 ± 0.05 mm [0.866 ± 0.002 in.] above the top surface of the vise.

6.2.6 Means shall be provided for determining the energy expended by the pendulum in breaking the specimen. This may consist of a pointer and dial mechanism or it may consist of an electronic determination provided with a digital display. The device will indicate the height of rise of the pendulum beyond the point of impact in terms of energy removed from the specific pendulum. The indicated energy must be corrected for friction and pendulum windage. Instructions for making these corrections are included in 9.3, Appendix X2, and Appendix X3. Electronic displays may automatically correct for windage and friction.

6.3 *Vise*, for clamping the specimen rigidly in position so that the long axis of the specimen is vertical and at right angles to the top plane of the vise. The top edges of the jaws of the vise shall have a radius of 0.25 ± 0.12 mm [0.010 ± 0.005 in.] (see Fig. 2).

NOTE 5—It is especially important that the correct radius be maintained on the moveable vise jaw. Any sharp edge, nick, or burr on this jaw will create a “notch” or stress concentration point when the jaw is clamped against the test specimen. This stress concentration point has lowered values of some materials to less than 50 % of the value obtained when the jaw has the correct radius.

6.3.1 It is very important that exactly 31.75 ± 0.25 mm [1.25 ± 0.010 in.] of the specimen project above the top surface of the vise (see 9.5).

NOTE 6—Some plastics are sensitive to clamping pressure. For this reason, cooperating laboratories should agree upon some means of standardizing the clamping force, such as with a torque wrench on the screw of the specimen vise or by use of standardized pneumatic or

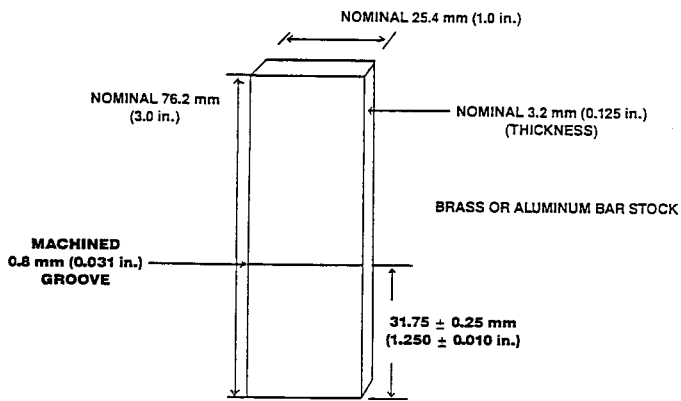

FIG. 3 Sketch of Positioning Jig

hydraulic cylinders with specified supply pressure. If the faces of the vise or specimen are not flat and parallel, a greater sensitivity to clamping pressure may be evident. See the calibration procedure in [Appendix X1](#) for adjustment and correction instructions for faulty instruments.

6.4 The vise, pendulum, and frame shall be sufficiently rigid to ensure correct alignment of the hammer and specimen, both at the moment of impact and during the propagation of the fracture, and to minimize energy losses due to vibration. The base shall be sufficiently massive that the impact will not cause it to move. The machine shall be so designed, constructed, and maintained that energy losses due to pendulum air drag (windage), friction in the pendulum bearings, and friction and inertia in the indicating mechanism, are held to a minimum.

6.5 A check of the calibration of an impact machine is difficult to make under dynamic conditions. The basic parameters are normally checked under static conditions; if the machine passes the static tests, then it is assumed to be accurate. The calibration procedure in [Appendix X1](#) shall be used to establish the accuracy of the equipment. However, for some machine designs it might be necessary to change the recommended method of obtaining the required calibration measurements. Other methods of performing the required checks may be substituted provided that they can be shown to result in an equivalent accuracy. [Appendix X1](#) also describes a dynamic test for checking certain features of the machine and specimen.

6.6 A Simple Jig (see [Fig. 3](#)), to facilitate proper positioning of the test specimen may be constructed from brass or aluminum bar stock of 3.2 by 25-mm [$\frac{1}{8}$ by 1-in.] cross section and having a length of 76 mm [3 in.]. From one end of the metal bar, carefully machine a narrow groove of 0.8-mm [$\frac{1}{32}$ -in.] depth across the 25-mm [1-in.] face of the bar at a distance of 31.75 ± 0.25 mm [1.250 ± 0.010 in.] from the selected end.

6.7 *Micrometers*, suitable micrometers with a resolution of 0.025 mm [0.001 in.] or better shall be used to measure the thickness of the test specimen. The micrometer shall conform to the applicable provisions of Test Methods [D 5947](#).

7. Test Specimens

7.1 Unless specifically noted, test specimens shall have the following dimensions:

7.1.1 *Depth*— 12.70 ± 0.15 mm [0.500 ± 0.006 in.],

7.1.2 *Length*—63.50 mm [2.500 in.], max, 60.30 mm [2.375 in.], min, and

7.1.3 *Preferred Width*— 3.17 ± 0.13 mm [0.125 ± 0.005 in.].

NOTE 7—For clarification purposes, width is the dimension of the test specimen face struck by the pendulum hammer.

7.1.4 The tolerance for test specimen depth was chosen on the basis of molding considerations. (**Warning**—Interlaboratory testing has indicated that this tolerance range appears to be suitable for most, but not all, materials. For a few materials, the impact strength may be found to vary with the specimen depth at the extremes of the above tolerance range. Users of the test method should check each material type; if such a dependency is found, a tolerance of ± 0.05 mm [± 0.002 in.] is required.)

7.1.5 Longitudinal edge faces must be parallel within 0.025 mm [0.001 in.]. Thinner specimens should be avoided since they usually twist in the clamping vise. Test specimens greater than 6.35 mm [0.250 in.] in width should be avoided.

7.2 Molded test specimens should be injection molded to the depth and width stated above ([Note 8](#)). If longer bars are molded, test specimens cut from the gate end of the bar shall not be used. Comparisons between injection-molded and injection-molded machined test specimens or molded-to-length and cut-to-length test specimens should be avoided unless representing a variation being studied.

NOTE 8—The type of mold and molding machine used and the flow behavior in the mold cavity will influence the results obtained. Cooperating laboratories should agree on standard molds and upon a standard molding procedure for the material under investigation.

7.3 For sheet materials, the specimens shall be cut from the sheet in both the lengthwise and crosswise directions, unless the sheets are known to be isotropic. The test specimen width shall be the thickness of the sheet.

7.4 Test specimens prepared by other means may also be used. Results from two sets of data may not be comparable if different means of test specimen preparation are used. A statement about test specimen preparation shall be part of the report (see [10.1.2](#)).

7.5 The practice of cementing, bolting, clamping, or otherwise combining thinner specimens to form a composite test specimen should be avoided since test results may be seriously affected by interface effects.

7.6 Each test specimen shall be free of twist, deformation, nicks, scratches, pits, and sink marks. Any test specimen showing observable or measurable departure from one or more of these requirements shall be rejected.

8. Conditioning

8.1 Specimen Conditioning:

8.1.1 Condition the test specimens at $23 \pm 2^\circ\text{C}$ [$73.4 \pm 3.6^\circ\text{F}$] and $50 \pm 5\%$ relative humidity for not less than 40 h prior to test in accordance with Procedure A of Practice [D 618](#), unless otherwise specified by contract or relevant material specification, or unless it has been shown that conditioning is not necessary. In cases of disagreement, the tolerances shall be $\pm 1^\circ\text{C}$ [$\pm 1.8^\circ\text{F}$] and $\pm 2\%$ relative humidity.

8.1.2 Materials known to be sensitive to moisture absorption should not be conditioned as stated above. Other conditioning procedures appropriate for the material (for example, “dry as molded”) should be used and stated in the report.

8.2 *Test Conditions*—Conduct tests in the standard laboratory atmosphere of $23 \pm 2^\circ\text{C}$ [$73.4 \pm 3.6^\circ\text{F}$] and $50 \pm 5\%$ relative humidity, unless otherwise specified in the contract or relevant material specification. In cases of disagreement, the tolerances shall be $\pm 1^\circ\text{C}$ [$\pm 1.8^\circ\text{F}$] and $\pm 2\%$ relative humidity.

9. Procedure

9.1 At least five and preferably ten or more individual determinations of impact value must be made on each sample group. Each group shall consist of specimens of one nominal thickness only. In the case of specimens cut from sheets that are suspected of being anisotropic, prepare and test specimens from each principal direction (lengthwise and crosswise to the direction of anisotropy).

9.2 Estimate the breaking energy for the specimen and select a pendulum of suitable energy. Use the lightest standard pendulum that is expected to break each specimen in the group with a loss of not more than 85 % of its energy (Note 10). Check the machine with the proper pendulum in place for conformity with the requirements of Section 6 before starting the tests (see Appendix X1).

NOTE 9—Ideally an impact test would be conducted at a constant test velocity. In a pendulum-type test the velocity decreases as the fracture progresses. For specimens that have an impact energy approaching the capacity of the pendulum, there is insufficient energy to complete the break and toss. By avoiding the higher 15 % scale energy readings, the velocity of the pendulum will not be reduced below 1.33 m/s [4.4 ft/s]. On the other hand, the use of too heavy a pendulum would reduce the sensitivity of the reading.

9.3 If the machine is equipped with a mechanical pointer and dial, perform the following operations before testing the specimens:

9.3.1 With the indicating pointer in its normal starting position, but without a specimen in the vise, release the pendulum from its normal starting position and note the position the pointer attains after the swing as one reading of Factor A.

9.3.2 Without resetting the pointer or electronic indicator, raise the pendulum and release it again. The pointer should move up the scale an additional amount. Repeat this procedure until a swing causes no additional movement of the pointer and note the final reading as one reading of Factor B (see Note 10).

9.3.3 Repeat the operations in 9.3.1 and 9.3.2 several times and calculate and record the average A and B readings.

NOTE 10—Factor B is an indication of the energy lost by the pendulum to friction in the pendulum bearings and to windage. The difference $A - B$ is an indication of the energy lost to friction and inertia in the indicating mechanism. The actual corrections, however, will be smaller than these factors, since in an actual test the energy absorbed by the specimen prevents the pendulum from making a full swing. Therefore, the indicated breaking energy of the specimen must be included in the calculation of the machine correction before determining the breaking energy of the specimen (see 9.7). The A and B values also provide an indication of the condition of the machine.

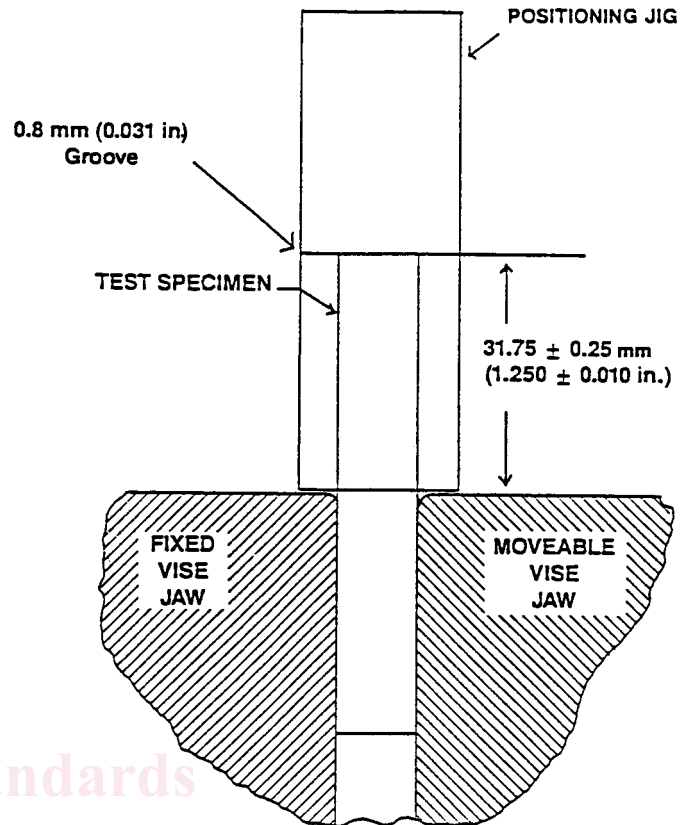

FIG. 4 Diagram Showing Clamped Test Specimen and Positioning Jig Before Removal

9.3.4 If excess friction is indicated, the machine shall be adjusted before starting a test. If the machine is equipped with a digital energy indicating system, follow the manufacturer’s instructions to correct for windage and friction.

9.4 Check the specimens for conformity with the requirements of Section 7. Measure the thickness and width of each specimen in the middle with a micrometer caliper to the nearest 0.025 mm [0.001 in.] and record, along with its identifying markings.

9.5 Position the specimen precisely and rigidly but not too tightly clamped in the vise (see Note 6). The end of the test specimen can be matched against the groove of the positioning jig when the jig is held vertically on the top surface of the vise (see Fig. 4). After clamping the specimen in the vise, remove the jig.

9.6 Release the pendulum and record the breaking energy together with a description of the appearance of the broken specimen (see failure categories in 5.6).

9.7 Subtract the windage and friction correction from the indicated breaking energy of the specimen, unless determined automatically by the indicating system (that is, digital display or computer). If a mechanical dial and pointer is employed, use the A and B factors and the appropriate tables or the graph described in Annexes A1 and A2 to determine the correction. For those digital systems that do not automatically compensate for windage and friction, follow the manufacturer’s procedure for performing this correction.

9.7.1 If the proper hammer was used, calculate the impact strength as follows:

TABLE 1 Unnotched Impact Strength

Material	Average Width, mm	Average Depth, mm	Average Impact Resistance of Specimen Width, J/m	Values Expressed as Percent of the Average			
				S_r^A	S_R^B	I_r^C	I_R^D
Polymethylmethacrylate	3.155	12.66	325.9	6.79	7.67	19.2	21.7
40 % talc-filled polypropylene	3.165	12.66	63.1	6.56	7.09	18.6	20.1
13 % glass-reinforced nylon ^E	3.106	12.75	421.5	7.75	8.91	21.9	25.2
20 % glass-reinforced acetal ^E	3.145	12.74	535.4	6.28	8.25	17.8	23.4
30 % glass-reinforced polyethylene terephthalate	3.076	12.61	926.0	11.9	13.7	33.7	38.7
Acrylonitrile-butadiene-styrene	3.073	12.69	1019	11.3	13.9	32.1	39.3

^A S_r = within-laboratory coefficient of variation of the average.

^B S_R = between-laboratories coefficient of variation of the average.

^C I_r = 2.83 S_r .

^D I_R = 2.83 S_R .

^E Data from nine laboratories.

$$\text{impact resistance} = (\text{corrected reading})/B \quad (2)$$

where:

corrected reading = net indicator value, J [ft-lbf], and
 B = test specimen width, m [in.] (see [Note 7](#)).

9.8 Calculate the average impact strength of the group of specimens. However, only values of specimens having the same nominal depth, width, and type of break may be averaged. Do not include values obtained from specimens that did not break in the manner specified in [5.6](#). Also calculate the standard deviation of the group of values.

10. Report

10.1 Report the following information:

10.1.1 Complete identification of the material tested, including type and manufacturer's code number,

10.1.2 A statement giving the specific details of the test specimen preparation (that is, cut from the center of a universal bar, machined from plaques, etc.), the testing conditions used, and for sheet materials, the direction of testing with respect to anisotropy, if any,

10.1.3 The capacity of the pendulum, J [ft-lbf or in.-lbf],

10.1.4 The measured width and thickness of each test specimen, mm [in.], and the average,

10.1.5 The total number of specimens tested per sample of material (that is, five, ten, or more),

10.1.6 The number of those specimens that resulted in failures conforming to each of the categories described in [5.6](#),

10.1.7 The average impact resistance in joules per metre of specimen width [or ft-lbf/in. of specimen width] of the specimens of [10.1.6](#) for each failure category except nonbreak,

10.1.8 The standard deviation of the values of the impact resistances of the specimens of [10.1.6](#),

10.1.9 The percent of specimens failing in each category suffixed by the corresponding letter codes from [5.6](#),

10.1.10 Date of testing, and

10.1.11 Test method number and revision date.

11. Precision and Bias ³

11.1 [Table 1](#) is based on a round robin conducted in 1985,

involving six materials tested by ten laboratories. For each material, all the samples were injection molded by the material supplier. Samples of polymethylmethacrylate were molded to length. Samples of polypropylene, polyethylene terephthalate, and acrylonitrile-butadiene-styrene (ABS) were molded as longer bars and cut to length by the supplier. Samples of nylon and acetal materials were molded as longer bars and sealed in moisture-proof pouches. Test specimens of these two materials were prepared immediately before testing by the individual laboratories. Each test result was the average of five individual determinations. Each laboratory obtained one test result for each material. (**Warning**—The following explanations of I_r and I_R ([11.2-11.2.3](#)) are only intended to present a meaningful way of considering the *approximate* precision of this test method. The data in [Table 1](#) should not be rigorously applied to acceptance or rejection of material, as those data are specific to the round robin and may not be representative of other lots, conditions, materials, or laboratories. Users of this test method should apply the principles outlined in [Practice E 691](#) to generate data specific to their laboratory and materials or between specific laboratories. The principles of [11.2](#) and [11.2.3](#) would then be valid for such data.)

11.2 *Concept of I_r and I_R* —If S_r and S_R have been calculated from a large enough body of data, and for test results that were averages from testing five specimens:

11.2.1 *Repeatability, I_r* (Comparing two test results for the same material, obtained by the same operator using the same equipment on the same day)—The two test results should be judged not equivalent if they differ by more than the I_r value for that material.

11.2.2 *Reproducibility, I_R* (Comparing two test results for the same material, obtained by different operators using different equipment on different days)—The two test results should be judged not equivalent if they differ by more than the I_R value for that material.

11.2.3 Any judgment made in accordance with [11.2.1](#) and [11.2.2](#) would have an approximate 95 % (0.95) probability of being correct.

11.3 *Bias*—Bias is systematic error which contributes to the difference between a test result and a true (or reference) value. There are no recognized standards on which to base an estimate of bias for this test method.

³ Supporting data are available from ASTM Headquarters. Request RR: D20-1147.