



Designation: E839 – 05

Standard Test Methods for Sheathed Thermocouples and Sheathed Thermocouple Material¹

This standard is issued under the fixed designation E839; the number immediately following the designation indicates the year of original adoption or, in the case of revision, the year of last revision. A number in parentheses indicates the year of last reapproval. A superscript epsilon (ϵ) indicates an editorial change since the last revision or reapproval.

INTRODUCTION

Thermocouples are widely used in industry and they provide reliable service. However, if thermocouples fail in service, the consequences can range from negligible to life threatening. Often a loss of equipment, product, or operating time will result. The user should weigh the potential consequences of thermocouple failure when considering what tests should be performed. No tests are required by this document except those specifically ordered by the user. This document lists methods for testing sheathed thermocouples and thermocouple material but does not state criteria for acceptance. The acceptance criteria for the particular thermocouple, when subjected to the tests, are given in other ASTM standard specifications for that thermocouple. Examples from ASTM thermocouple specifications for acceptance criteria are given for many of the tests. These tabulated values are *not* necessarily those that would be required to meet these tests, but are given here as examples only.

Users should be aware that certain characteristics of thermocouple materials, including the emf versus temperature relationship may change with time in use; consequently, test results and performance obtained at time of manufacture may not necessarily apply throughout an extended period of use. It should be further noted that due to possible changes in homogeneity, attempting to recalibrate used thermocouples is likely to yield irrelevant results, and is not recommended.

1. Scope

1.1 These are test methods for sheathed thermocouple material and assemblies.

1.2 The tests are intended to ensure quality control and to evaluate the suitability of sheathed thermocouple material or assemblies for specific applications. Some alternative test methods to obtain the same information are given, since in a given situation an alternative test method may be more practical. Service conditions are widely variable and so it is unlikely that all the tests described will be appropriate for a given thermocouple application. A brief statement is made following each test description to indicate when it might be used.

1.3 The tests described herein include test methods to measure the following properties of sheathed thermocouple material and assemblies.

1.3.1 Insulation Properties:

1.3.1.1 Compaction—absorption method and tension method.

1.3.1.2 Thickness.

1.3.1.3 Resistance—room temperature and elevated temperature.

1.3.2 Sheath Properties:

1.3.2.1 Integrity—water test (two test methods) and mass spectrometer.

1.3.2.2 Dimensions—length, diameter, and roundness.

1.3.2.3 Wall thickness.

1.3.2.4 Surface—gross visual, finish, defect detection by dye penetrant, and cold-lap detection by tension test.

1.3.2.5 Metallurgical structure.

1.3.2.6 Ductility—bend test and tension test.

1.3.3 Thermolement Properties:

1.3.3.1 Calibration.

1.3.3.2 Homogeneity.

1.3.3.3 Drift.

1.3.3.4 Thermolement diameter, roundness, and surface appearance.

1.3.3.5 Thermolement spacing.

1.3.3.6 Thermolement ductility.

1.3.3.7 Metallurgical structure.

¹ These test methods are under the jurisdiction of ASTM Committee E20 on Temperature Measurement and is the direct responsibility of Subcommittee E20.04 on Thermocouples.

Current edition approved Nov. 1, 2005. Published December 2005. Originally approved in 1989. Last previous edition approved in 1996 as E839 – 96 which was withdrawn in August 2005 and reinstated in November 2005. DOI: 10.1520/E0839-05.

- 1.3.4 *Thermocouple Assembly Properties:*
- 1.3.4.1 Dimensions—length, diameter, and roundness.
- 1.3.4.2 Surface—gross visual, finish, reference end seal, and defect detection by dye penetrant.
- 1.3.4.3 Electrical—continuity, loop resistance, and connector polarity.
- 1.3.4.4 Radiographic inspection.
- 1.3.4.5 Thermoelement diameter.
- 1.3.4.6 Thermal response time.
- 1.3.4.7 Thermal cycle.

2. Referenced Documents

2.1 ASTM Standards:²

- D2771 Test Methods for Compaction Density of Electrical Grade Magnesium Oxide³
- E3 Guide for Preparation of Metallographic Specimens
- E94 Guide for Radiographic Examination
- E112 Test Methods for Determining Average Grain Size
- E142 Method for Controlling Quality of Radiographic Testing³
- E165 Practice for Liquid Penetrant Examination for General Industry
- E207 Test Method for Thermal EMF Test of Single Thermoelement Materials by Comparison with a Reference Thermoelement of Similar EMF-Temperature Properties
- E220 Test Method for Calibration of Thermocouples by Comparison Techniques
- E230 Specification and Temperature-Electromotive Force (EMF) Tables for Standardized Thermocouples
- E235 Specification for Thermocouples, Sheathed, Type K and Type N, for Nuclear or for Other High-Reliability Applications
- E344 Terminology Relating to Thermometry and Hydrometry
- E585/E585M Specification for Compacted Mineral-Insulated, Metal-Sheathed, Base Metal Thermocouple Cable
- E608/E608M Specification for Mineral-Insulated, Metal-Sheathed Base Metal Thermocouples
- E780 Test Method for Measuring the Insulation Resistance of Mineral-Insulated, Metal-Sheathed Thermocouples and Thermocouple Cable at Room Temperature
- E988 Temperature-Electromotive Force (EMF) Tables for Tungsten-Rhenium Thermocouples
- E1129/E1129M Specification for Thermocouple Connectors
- E1350 Guide for Testing Sheathed Thermocouples, Thermocouples Assemblies, and Connecting Wires Prior to, and After Installation or Service
- E1684 Specification for Miniature Thermocouple Connectors
- E1751 Guide for Temperature Electromotive Force (EMF)

² For referenced ASTM standards, visit the ASTM website, www.astm.org, or contact ASTM Customer Service at service@astm.org. For *Annual Book of ASTM Standards* volume information, refer to the standard's Document Summary page on the ASTM website.

³ Withdrawn. The last approved version of this historical standard is referenced on www.astm.org.

Tables for Non-Letter Designated Thermocouple Combinations³

E2181/E2181M Specification for Compacted Mineral-Insulated, Metal-Sheathed, Noble Metal Thermocouples and Thermocouple Cable

2.2 ANSI Standard

B 46.1 Surface Texture⁴

3. Terminology

3.1 *Definitions*—The definitions given in Terminology E344 shall apply to these test methods.

3.2 Definitions of Terms Specific to This Standard:

3.2.1 *bulk cable, n*—a single length of thermocouple cable (produced from the same raw material lot) after completion of fabrication resulting in sheathed thermocouple material.

3.2.2 *cable lot, n*—a quantity of finished mineral-insulated, metal-sheathed thermocouple cable manufactured from tubing from the same heat, wire from the same spool and heat, and insulation from the same batch then assembled and processed together under controlled production conditions to the required final outside diameter.

3.2.3 *cold-lap, n*—sheath surface defects where the sheath surface has been galled and torn by a drawing die and the torn surface smoothed by a subsequent diameter reduction.

3.2.4 *insulation compaction density, n*—the density of a compacted powder is the combined density of the powder particles and of the voids remaining after the powder compaction. Sometimes the insulation compaction density is divided by the theoretical density of the powder particles to obtain a dimensionless fraction of theoretical density as a convenient method to express the relative compaction.

3.2.5 *raw material, n*—tubing, insulation and wires used in the fabrication of sheathed thermocouple cable.

3.2.6 *short range ordering, n*—the reversible short-ranged, order-disorder transformation in which the nickel and chromium atoms occupy specific (ordered) localized sites in the Type EP or Type KP thermoelement alloy crystal structure.

3.2.7 *thermocouple assembly, n*—the cut-to-length, finished assembly consisting of thermocouple material with thermoelements having one end joined in a measuring junction. The assembly has the sheath closed at the measuring end and has a moisture seal at the reference junction end of the sheath. The assembly does not include a reference junction but may include a thermocouple connector, thermocouple extension, or compensating wire.

4. Summary of Test Methods

4.1 Insulation Properties:

4.1.1 *Compaction*—These tests ensure that the insulation is compacted sufficiently (1) to prevent the insulation from shifting during use with the possibility of the thermoelements shorting to each other or to the sheath, and (2) to have good heat transfer between the sheath and the thermoelements.

4.1.2 *Insulation Resistance*—The insulation must be free of moisture and contaminants that would compromise the

⁴ Available from American National Standards Institute (ANSI), 25 W. 43rd St., 4th Floor, New York, NY 10036.

voltage-temperature relation or shorten the useful life of the sheathed thermocouple. Measurement of insulation resistance is a useful way to detect the presence of unacceptable levels of impurities in the insulation.

4.2 *Sheath Properties:*

4.2.1 *Integrity*—These tests ensure that (1) the sheath will be impervious to moisture and gases so the insulation and thermoelements will be protected, (2) surface flaws and cracks that might develop into sheath leaks are detected, and (3) the sheath walls are as thick as specified.

4.2.2 *Dimensions*—Determination of length, diameter, and sheath roundness are often necessary to assure proper dimensional fit.

4.2.3 *Sheath Ductility*—The sheath must be ductile enough to bend the required amount without breaking or cracking.

4.3 *Thermoelement Properties Service Life:*

4.3.1 *Calibration*—These tests ensure that the temperature-emf relationship corresponds to the standard values both initially and after a short time of heating to service temperatures.

4.3.2 *Size*—The thermocouple sheath and thermoelement sizes are related to service life and the thermoelement spacing is related to possible low insulation resistance or shorting.

4.3.3 *Thermoelement Ductility*—Ductility of the thermoelements must be sufficient to allow the assembly to be bent during assembly or service without significant damage to the thermoelements.

4.4 *Thermocouple Assembly Properties*—The criteria listed above must apply to both thermocouple assemblies and to bulk cable, and in addition, the following tests are important for thermocouple assemblies.

4.4.1 *Continuity*—The loop continuity test assures that the thermocouple assembly has a completed circuit.

4.4.2 *Loop Resistance*—The loop resistance test can detect shorted or damaged thermoelements.

4.4.3 *Polarity*—The connector polarity test indicates whether the connector is correctly installed.

4.4.4 *End Seal*—The end seal, if faulty, may allow the contamination of the insulation with moisture or gases.

4.4.5 *Radiography*—Radiographic examination of the junction and sheath closure weld can indicate faulty junctions and sheath closures that will lead to early failure. The internal dimensions can also be measured from the radiograph.

4.4.6 *Response Time*—The thermal response time gives an indication of the quickness with which an installed thermocouple will signal a changing temperature under the test conditions.

4.4.7 *Thermal Cycle*—The thermal cycle test will offer assurance that the thermocouple will not have early failure because of strains imposed from temperature transients.

5. Significance and Use

5.1 This test method provides a description of test methods used in ASTM specifications that establish certain acceptable limits for characteristics of thermocouple assemblies and thermocouple cable.

5.2 The intended use of these test methods is to define the methods by which the characteristics shall be determined.

5.3 The usefulness and purpose of the included tests are given for the category of tests.

6. General Requirements

6.1 All the inspection operations are to be performed under clean conditions (that is, conditions that will not degrade the insulation, sheath, or thermoelements), including the use of suitable gloves when appropriate.

6.2 During all process steps in which insulation is exposed to ambient atmosphere, the air must be clean, with less than 50 % relative humidity, and at a temperature between 20 and 26 °C (68 and 79 °F).

6.3 All samples which are tested shall be identified by material code, and shall be traceable to a production run.

7. Insulation Properties

7.1 *Insulation Compaction Density*—The thermal conductivity of the insulation, as well as the ability of the insulation to lock the thermoelements into place, will be affected by the insulation compaction density.

7.1.1 Test Methods **D2771** is a test on representative specimen to measure the compaction density of electrical grade magnesium oxide. Two methods are used to find the density: Test Method A for water displacement and Test Method B for oil absorption. Both Test Methods A and B require precision weighing and careful procedure.

7.1.2 A direct measurement test of insulation compaction density is applicable if a representative sample can be sectioned so the sample ends are perpendicular to the sample length and the sheath, thermoelements, and insulation form a smooth surface free of burrs. The test procedure is to:

7.1.2.1 Weigh the sample section,

7.1.2.2 Measure the sheath diameter and length with a micrometer,

7.1.2.3 Separate wires, sheath, and insulation by use of an air abrasive tool (air-driven abrasive particles) to remove the insulation from the sample,

7.1.2.4 Weigh the thermoelements and sheath, and

7.1.2.5 Determine the sheath and thermoelements densities either by experiment or from references.

7.1.3 The fraction of the maximum theoretical insulation density is determined as follows:

$$(A - B)/\{[0.785 C^2 D - (E/F + G/H)]J\} \quad (1)$$

where:

A = total specimen mass, kg or lb,

B = sheath and wires mass, kg or lb,

C = sheath diameter, m or in.,

D = specimen length, m or in.,

E = sheath mass, kg or lb,

F = sheath density, kg/m³ or lb/in.³,

G = wires mass, kg or lb,

H = wires density (averaged density if applicable), kg/m³ or lb/in.³, and

J = maximum theoretical density of the insulation, kg/m³ or lb/in.³.

7.2 *Insulation Compaction, Tension Test Method*—This is a destructive test on representative samples that determines if the thermoelements are locked together with the sheath by the

compacted insulation, but the test does not measure the compaction density per se. This tension test is the complement of the tests of 7.1 that measure the insulation compaction density but does not establish that the thermoelements are locked to the sheath (since there is no established minimum compaction density where locking begins). This test can be performed concurrently with the sheath ductility test (8.5.3).

7.2.1 Cut a test specimen about 0.5 m (20 in.) long from one end of a bulk material length and strip both ends of the specimen to expose a minimum of 10 mm (0.4 in.) of the thermoelements.

7.2.2 Without sealing the exposed insulation, clean the thermoelements (wires) of insulation to provide good electrical contact and twist the wires together on one end to form a thermocouple loop (Fig. 1).

7.2.3 Measure the electrical resistance of the thermocouple loop to $\pm 0.01 \Omega$ and measure the length of the thermocouple loop to establish the electrical resistance per unit length.

7.2.4 Place the test sample in the tension testing machine so that (1) the grips clamp only on the sample sheath, (2) the force will be applied longitudinally on the sheath, and (3) there is at least a 0.25-m (10-in.) distance between the grips where the force will be applied (Fig. 2).

7.2.5 Attach an ohmmeter capable of measuring $\pm 0.01 \Omega$ to the exposed thermoelements and measure the resistance with no tension force applied; also measure the distance between the tension tester grips to establish the initial length, L_0 , of the test sample that will be elongated.

7.2.6 Calculate the initial resistance, R_0 , of the test specimen section that will be elongated, using the unit length electrical resistance obtained in 7.2.3.

7.2.7 Make a simultaneous record of the electrical resistance and the elongation of the sheath while stretching the test sample until the thermoelements break.

7.2.8 Examine the exposed ends of the thermoelements to see whether they have been drawn into the insulation during the elongation; any shortening of the exposed ends indicates low compaction of the insulation.

7.2.9 Plot the fractional change of resistance ($\Delta R/R_0$) versus the fractional change of length ($\Delta L/L_0$). The slope of the plot reveals if the thermoelements were locked to the sheath throughout the plastic deformation of the sheath and, if not, where the thermoelements began to elongate in a different manner than the sheath. Examples of criteria to evaluate the insulation locking are given in X1.9

7.3 *Insulation Thickness Measurement*—Determine the dimension C of Fig. 3 from a metallographic mount, prepared in

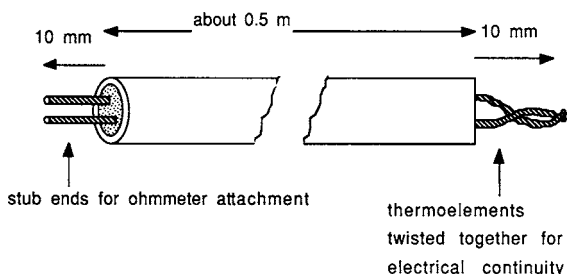

FIG. 1 Specimen of Sheathed Thermocouple Material Prepared for Tension Testing

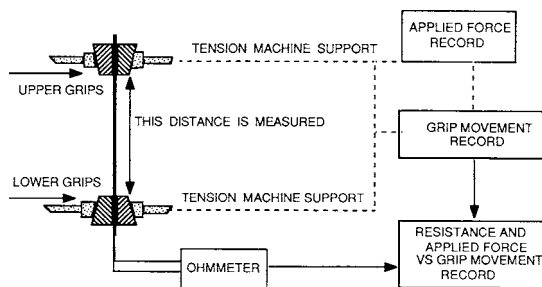

FIG. 2 The Thermocouple Positioned in the Tension Tester

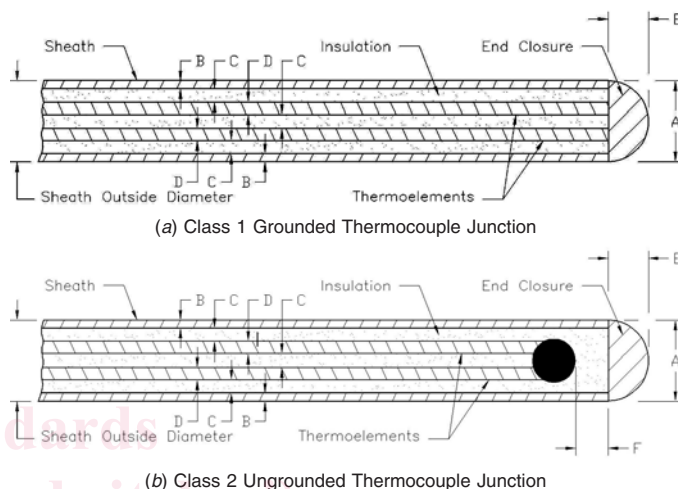

FIG. 3 Sheathed Thermocouple Assembly

accordance with Practice E3 of a polished cross section of the thermocouple using a microscope having at least a 60 \times magnification and a 2.5-mm (0.1-in.) reticle graduated in at least 0.03-mm (0.001-in.) increments. Sampling frequency, measurement tolerance, and insulation thickness shall be as stated in the standard specification relevant to the subject thermocouple. Examples of specifications for the insulation thickness are given in the Measuring Junction Configuration section of Specification E608/E608M for the junction area, in the General Dimensional Requirements of Specification E585/E585M and in Tables X1.1 and X1.2.

7.4 *Insulation Resistance, Room Temperature*—Measure the insulation resistance of sheathed thermocouple material at room temperature using Test Method E780. Sampling frequency and insulation resistance shall be as stated in the relevant invoking thermocouple specification, or as agreed upon between the purchaser and the producer. See Table X1.3.

7.5 *Insulation Resistance, Elevated Temperatures*—The purpose of this test is to determine if the thermocouple insulation will be adequate for high temperature use of the thermocouple (**Warning**—All thermocouples may have changes in thermoelectric homogeneity produced by exposure to elevated temperatures; therefore, this test should be regarded as possibly destructive.) Sampling frequency shall be as stated in the standard specification relevant to the subject thermocouple.

7.5.1 *Thermocouple Assembly*—Measure the electrical resistance between the thermoelements and the sheath for a Class

2 (ungrounded junction) finished thermocouple assembly (Fig. 3) using the technique of Test Method E780 (Resistance Measurement). Insert the measuring junction of the finished thermocouple into a furnace or constant temperature bath to a depth that will yield maximum temperature stability (example: 20 sheath diameters). Then, the thermocouple junction can be heated to the test temperature. This procedure is not applicable to a Class 1 (grounded junction) thermocouple assembly.

7.5.1.1 The minimum acceptable insulation resistance between the thermoelements and the sheath, while the test specimen is at the specified elevated temperature, shall be as stated in the standard specification relevant to the subject thermocouple assembly.

7.5.2 Bulk Cable—Insulation resistance tests on sheathed thermocouple cable at elevated temperatures have the purpose of determining (1) if excess moisture is in the insulation of the bulk cable, or (2) if the insulation contains excess impurities other than moisture, which will affect the insulation resistance at high temperatures.

7.5.2.1 Elevated Temperature, Moisture and Impurities Combined—The steps listed for this test are intended to evaluate the combined effects of insulation impurities on the elevated temperature resistance of Type K or N bulk material. (Warning—Improper technique in constructing thermocouple assemblies can introduce additional insulation impurities.)

(1) Cut a specimen of approximately 1.2 m (4 ft) in length from the end of the bulk material. Strip both ends of the sample about 25 mm (1 in.) to expose the thermoelements and at once seal the ends with an insulating sealant such as epoxy to prevent further moisture absorption. Wind the center section of the specimen around a 25-mm (1-in.) mandrel to form three coils, as shown in Fig. 4. The coils use about 0.3 m (1 ft) of the specimen.

(2) Install a suitable connector on one end of the coil and test the room temperature insulation resistance as described in 7.4.

(3) Insert the sample coil into a furnace and bring the coil temperature to $1000 \pm 10^\circ\text{C}$. The sealed ends of the sample should be kept near room temperature. Allow the sample to

stabilize at 1000°C for at least 15 min, as measured by the furnace monitor thermocouple.

(4) Measure the insulation resistance at the voltage and range appropriate for readability and the thermocouple sheath diameter. The charge time of the megohm tester should be 1 min before the measurement is recorded.

(5) Record the insulation resistance between each thermoelement, and from each thermoelement to the sheath.

7.5.2.2 Elevated Temperature, Contaminants Other than Moisture—The steps listed for this test evaluate the effects of impurities in the insulation (other than moisture) on the insulation resistance of the bulk material at elevated temperatures.

(1) Cut a specimen about 0.6 m (2 ft) long from the end of the bulk material to be tested. Strip both ends about 25 mm (1 in.) to expose the thermoelements.

(2) Weld extension wires to each of the thermoelements and to the sheath, as shown in Fig. 5. The extension wires need not be the same composition as the thermoelements, but the extension wire must withstand the temperature of the test and the same composition extension wire should be used for all connections to the specimen.

(3) Wind the center section of the specimen around a 25-mm (1-in.) mandrel to form three coils, as shown in Fig. 5. The coils use about 0.3 m (1 ft) of the sample.

(4) Install a suitable terminal strip or connector to the extension wires, as shown in Fig. 5 and test the room temperature insulation resistance as described in 7.4.

(5) Insert the sample coil into a furnace so that the extension wires are in the same uniform temperature zone as the coil and bring the coil temperature to $1000 \pm 10^\circ\text{C}$. Allow the sample to stabilize to the test temperature for at least 15 min, as measured by the furnace monitor thermocouple.

(6) Measure the insulation resistance at the voltage appropriate for the thermocouple sheath diameter. The charge time of the megohm tester should be 1 min before the measurement is recorded.

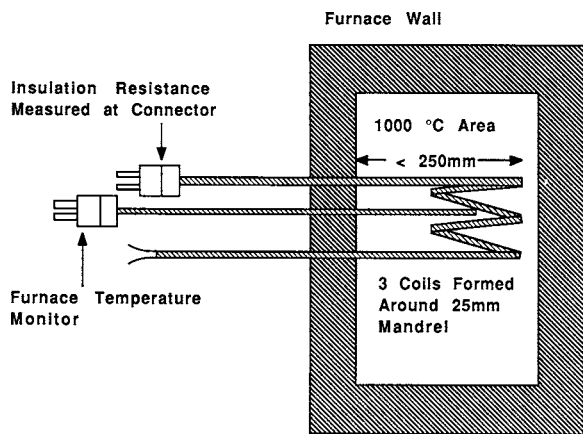

NOTE—The ends of the test specimen are sealed with epoxy to prevent water vapor from being adsorbed or desorbed during the test.

FIG. 4 High Temperature Insulation Resistance Test Assembly to Test for Moisture Plus Impurities

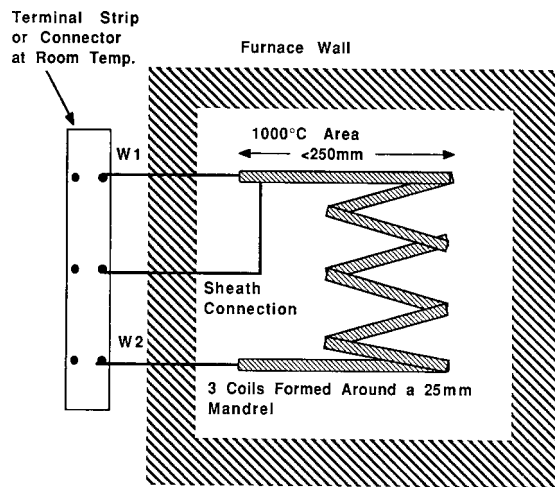

NOTE—The ends of the test specimen are not sealed, allowing water vapor to escape before measuring the insulation resistance

FIG. 5 High Temperature Insulation Resistance Test, Insulation Contamination Other Than Moisture

(7) Record the resistance between each thermoelement, and from each thermoelement to the sheath.

8. Sheath Properties

8.1 *Sheath Integrity*—Leakage of air or moisture into the sheath can be detrimental to the life and local homogeneity of the sheathed thermoelements. Penetrations of the sheath may be caused by holes left during the fabrication of the sheath tubing, cracks due to welding, holes because of incomplete closures at either of the measurement ends, or by other mechanical damage. Two major methods, water penetration and mass spectrometer measurements of helium penetration, are commonly used for assessing sheath integrity. The mass spectrometer method is the most sensitive and the only one that can be used with Class 1 (grounded junction) thermocouples. These sheath integrity test methods are given in order of increasing test sensitivity and difficulty. Before any sheath integrity tests are performed, wipe sheath with a rag dampened in solvent to remove oily surface contaminants.

8.1.1 *Fast Sheath Integrity Test Using Water*—This test is usually a test on bulk cable using a less sensitive ohmmeter and a lower voltage test than the test used in 8.1.2; it is the fastest test, intended to detect the larger sheath penetrations.

8.1.1.1 Strip one end of the length to bare a 6 mm (0.25 in.) length of thermoelements.

8.1.1.2 Check the opposite end of the length for any evidence of shorting of thermoelements to the sheath.

8.1.1.3 Seal the open ends with an insulating sealant to prevent the absorption of water vapor.

8.1.1.4 Using a direct-current (dc) ohmmeter, reading to at least 20 MW, connect the ground lead to the cable sheath and the other test lead to either thermoelement.

8.1.1.5 Then, wipe the length of the sheath with a rag saturated with cold tap water, slowly with a light pressure applied to the sheath, starting from the end opposite the instrument connection.

8.1.1.6 As an alternative, immerse the entire length (in a coil if necessary) in tap water, except for 2 %, but not to exceed 0.3 m (1 ft), at each end.

8.1.1.7 With the ohmmeter range selection switch on the most sensitive readable range, interpret any noticeable reduction of insulation resistance as evidence of a leak in the sheath.

8.1.1.8 The leaking section may be cut from the length of material and this test repeated to determine acceptability of the remaining portion of the finished length.

8.1.2 *Basic Sheath Integrity Test Using Water*.

8.1.2.1 Strip one end of the sheathed material to expose a minimum of 6 mm (0.25 in.) of the thermoelements.

8.1.2.2 Check the opposite end of the length for any evidence of shorting of thermoelements to the sheath.

8.1.2.3 Seal the open ends with an insulating sealant to prevent the absorption of water vapor.

8.1.2.4 Using a megohmmeter on the most sensitive readable range with an applied voltage at a minimum of 10 Vdc and at a maximum of 50 Vdc, measure the insulation resistance between the sheath and thermoelements.

8.1.2.5 Then, using a clean rag saturated with unheated tap water (water dripping from the rag), wipe along the length of the sheath from the end opposite the instrument connection at

a rate between 40 to 50 mm/s (7.9 to 9.8 ft/min) applying a light pressure to the rag circumferentially around the sheath thereby forcing the water into and through any fissure in the sheath wall. Set the material aside for 30 min after application of the water.

8.1.2.6 A more discriminating method to ensure detecting exceptionally small leaks is to immerse the entire length (coiled if necessary), including welded measuring junction end, in unheated tap water. Allow up to 2 %, but no more than 0.3 m (1 ft) of length on ends with insulating sealant to remain out of the water. Leave the material immersed in the water for a minimum of 16 h.

8.1.2.7 After the exposure to the water as required in 8.1.2.5 or 8.1.2.6, repeat the insulation resistance test of 8.1.2.4. Interpret a noticeable reduction in insulation resistance immediately upon exposure to the water, or after completion of either technique selected, as evidence of a leak in the sheath.

8.1.2.8 A technique to locate the leak, if one is detected, is to leave the voltage applied while the sheathed material is exposed to the water. This will often pinpoint the location of a leak by emitted bubbles due to the electrolysis of water.

8.1.2.9 The leaking section of the length of material may be removed and this test repeated to determine acceptability of the remaining portion of the finished length.

8.1.3 *Sheath Integrity, Mass Spectrometer Method*:

8.1.3.1 Test the sheath and measuring end closure as follows: Weld, or otherwise hermetically seal the cold end to prevent the detrimental absorption of moisture. Wipe the test item clean with a solvent-saturated cloth. Recommended solvents are alcohol, methyl ethyl ketone, or methyl isobutyl. (**Warning**—These solvents can be considered as hazardous and possibly toxic. Refer to applicable Material Safety Data Sheets.) Externally pressurize the sheath and measuring end closure with helium to at least 7.0 Mpa (66 atm) for a period of 5 to 10 min. Exclude the cold end moisture seal from helium pressurization to preclude damage. Wipe the test item again with a solvent-saturated tissue and insert within 2 h into a test chamber. Evacuate the interior of this chamber to a pressure of 7 kPa (50 mm Hg) or less, and test for the presence of helium using a mass spectrometer-type helium-leak detector. Monitor the test chamber for a time period of at least three times the *System Time Response* (8.1.3.3). Take an indication of helium leakage of 6×10^{-6} standard cubic centimeters per second as evidence of a leak.

8.1.3.2 Determine the sensitivity of the leak detector combined with the evacuated test chamber, hereafter called the system, using a standard leak or a calibrated leak of known leak rate before and after each test, or group of tests, on a given day. If the second sensitivity test shows system sensitivity less than the minimum value specified below, repeat all intervening leak tests on the item being tested.

8.1.3.3 Introduce the standard or calibrated leak into the system at the point farthest from the leak detector. The mass spectrometer-type helium-leak detector shall demonstrate a minimum system sensitivity of 3×10^{-9} standard cubic centimeters of helium per second as indicated on the smallest scale division on the leak detector meter. A leak rate of 6×10^{-9} standard cubic centimeter of helium per second shall