



Designation: D 3061 – 97<sup>ε1</sup>

# Standard Guide for Three-Piece Steel and Tinplate Straight-Wall and Necked-In Aerosol Cans<sup>1</sup>

This standard is issued under the fixed designation D 3061; the number immediately following the designation indicates the year of original adoption or, in the case of revision, the year of last revision. A number in parentheses indicates the year of last reappraisal. A superscript epsilon ( $\epsilon$ ) indicates an editorial change since the last revision or reappraisal.

*This standard has been approved for use by agencies of the Department of Defense.*

<sup>ε1</sup> NOTE—Corrections were made to the dimensions in Tables 3 and 4 in March 2000.

## 1. Scope

1.1 In the interest of uniformity and quality, the aerosol industry has developed dimensional guidelines which are suggested for U.S. three-piece steel and tin-plate aerosol cans of straight-wall and necked-in design. Domestic can makers uniformly agreed to comply with these guidelines and were instrumental in their development. A series of standard methods and gages were also developed to uniformly determine specific dimensions. The tolerances established for these dimensions allow for can manufacturing and filling process variations.

1.2 It is the purpose of this guide to provide a listing of currently manufactured aerosol can sizes as well as industry voluntary dimensional guidelines.

1.3 Table 1 and Table 2 present the sales code diameter and height of straight-wall and necked-in three-piece aerosol cans. The units in parentheses are in SI format, an alternate reference using dimensions suggested by the Metric Working Group of the Can Makers Institute. They are based on International Organization for Standardization (ISO) inside diameters to the nearest whole millimetre. Can heights are based on heights over the double seam (CSMA Dimension D) converted to the nearest whole millimetre.

## 2. Terminology

2.1 Specific dimensions used in this guide are described as follows and correspond to those associated with the cross-sectional drawings of straight-wall and necked-in aerosol cans (Fig. 1 and Fig. 2, respectively).

### 2.2 Dimensions and Definitions:

- 2.2.1 *A*—inside diameter of the 1-in. (25.4-mm) opening.
- 2.2.2 *B*—outside diameter of the 1-in. (25.4-mm) opening.
- 2.2.3 *C*—distance from the top of the curl of the 1-in. (25.4-mm) opening to the top of the top double seam.
- 2.2.4 *D*—distance from the top of the top double seam to the

<sup>1</sup> This specification is under the jurisdiction of ASTM Committee D10 on Packaging and is the direct responsibility of Subcommittee D10.33 on Mechanical Dispensers. Originally developed by the Chemical Specialties Manufacturers Assn. (CSMA).

Current edition approved Sept. 10, 1997. Published April 1998. Originally published as D 3061 – 72. Last previous edition D 3061 – 79 (1991).

**TABLE 1 Sales Code Height for Various Diameters of Straight-Wall Aerosol Cans (SI)**

| 202 (52 mm) by | 207.5 (60 mm) by | 211 (65 mm) by | 300 (73 mm) by |
|----------------|------------------|----------------|----------------|
| 214 ( 73)      | 509 (141)        | 413 (122)      | 709 (192)      |
| 306 ( 85)      | 605 (160)        | 600 (152)      |                |
| 314 ( 98)      | 701 (179)        | 604 (158)      |                |
| 406 (111)      | 703 (182)        | 612 (171)      |                |
| 505 (134)      | 708 (190)        | 713 (198)      |                |
| 509 (141)      | 713 (198)        | 908 (241)      |                |
| 700 (177)      |                  |                |                |
| 708 (190)      |                  |                |                |

bottom of the bottom double seam.

2.2.5 *E*—distance from the top of the curl of the 1-in. (25.4-mm) opening to the bottom of the bottom double seam.

2.2.6 *F*—distance between the bottom of the top double seam and the top of the bottom double seam.

2.2.7 *G*—curl thickness of the 1-in. (25.4-mm) opening measured using the special Starrett micrometer or equivalent.

2.2.8 *J*\*—vertical distance from the maximum snap-lock diameter to the bottom of the countersink.

2.2.9 *K*—outside diameter of the top double seam (excluding crossover).

2.2.10 *L*\*—width of the countersink at the maximum snap-lock diameter.

2.2.11 *M*\*—snap-lock undertuck.

2.2.12 *N*\*—outside diameter of the snap-lock.

2.2.13 *P*\*—snap-lock wall length, as measured vertically from the maximum snap-lock diameter to the point of maximum undertuck.

**TABLE 2 Sales Code Height for Various Diameters of Necked-In Aerosol Cans (SI)**

| 111/112 by<br>(45 mm) | 200/202 by<br>(52 mm) | 202/205 by<br>(57 mm) | 207.5/211 by<br>(65 mm) | 211/214 by<br>(70 mm) |
|-----------------------|-----------------------|-----------------------|-------------------------|-----------------------|
| 214 ( 73)             | 214 ( 73)             | 410 (117)             | 413 (122)               | 315 (100)             |
| 312 ( 95)             | 314 ( 98)             | 604 (158)             | 604 (158)               | 413 (122)             |
| 410 (117)             | 406 (111)             | 608 (165)             | 612 (171)               | 714 (200)             |
| 508 (139)             | 509 (141)             | 701 (179)             | 713 (198)               | 804 (209)             |
| 608 (165)             | 514 (149)             | 704 (184)             |                         | 1006 (263)            |
|                       | 700 (177)             | 710 (193)             |                         |                       |
|                       | 708 (190)             | 802 (206)             |                         |                       |
|                       |                       | 803 (207)             |                         |                       |

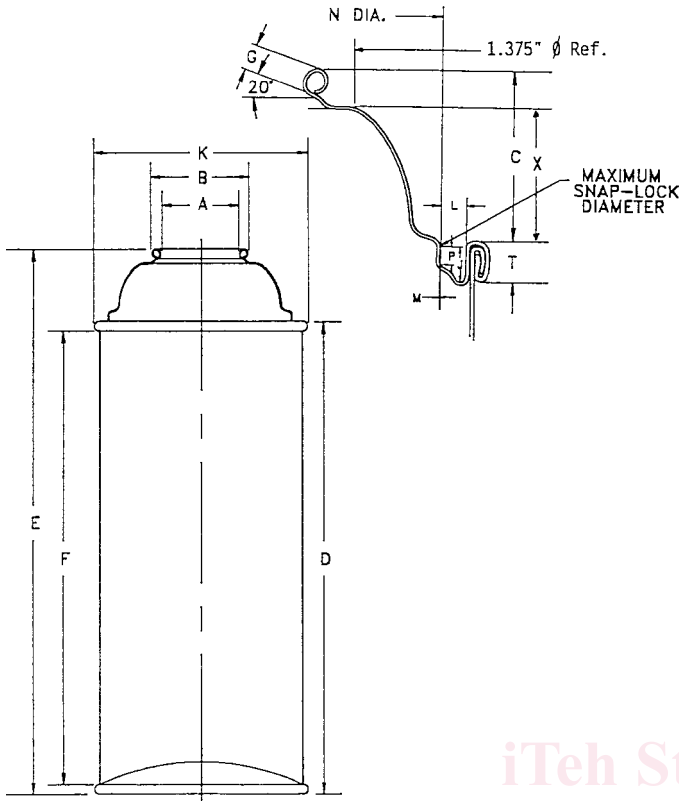

FIG. 1 Straight-Wall Aerosol Can

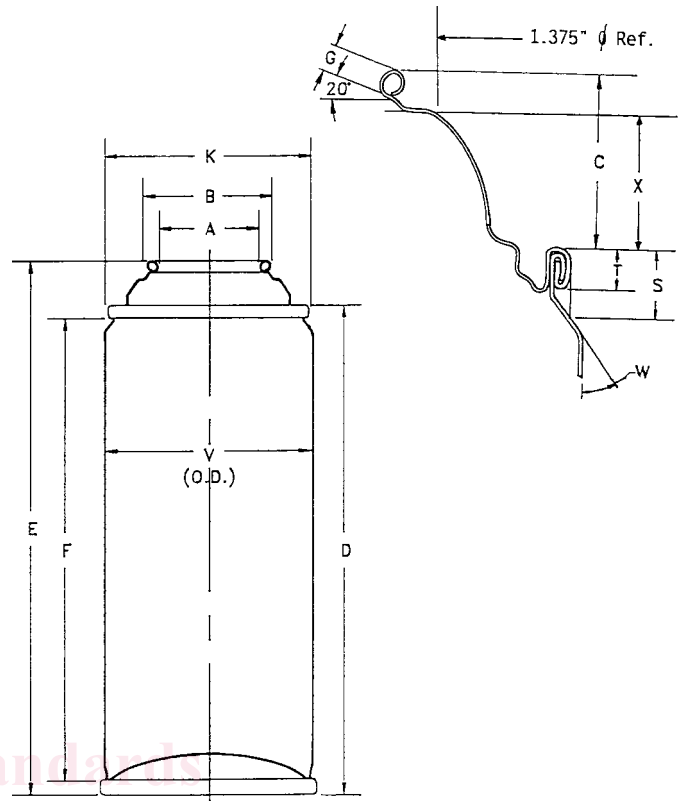

FIG. 2 Necked-In Aerosol Can

2.2.14 *S*—vertical distance, tangent to the outside diameter of the dome double seam, from the top of the dome double seam to the necked-in area of the can sidewall.

2.2.15 *T*—width or height of the top double seam.

2.2.16 *V*\*—body outside diameter of necked-in cans.

2.2.17 *W*—top neck angle of the body wall.

NOTE 1—\* Method of measurement to be agreed upon between the supplier and the user if needed.

### 3. Guideline Dimensions

3.1 The following tables provide guideline dimensions for straight-wall and necked-in three-piece aerosol cans (alternate tables furnish SI equivalents).

3.2 Various container heights (*D*, *E*, and *F*) are based on the following examples:

3.2.1 A typical 211 by 413 aerosol can has a Sales Code height of 413, or  $4\frac{13}{16}$  in., which converted to its decimal equivalent, is 4.812 in.. However, Dimension *D* is derived by subtracting 0.020 in. from the decimal conversion of the Sales Code height:

$$D = 4.812 \text{ in.} - 0.020 \text{ in.} = 4.792 \text{ in.} \quad (1)$$

3.2.2 Dimension *E* is obtained by adding the *C* Dimension to the *D* Dimension. The *C* Dimension is found in Tables 3-6,

depending on end diameter and unit of measure.

$$E = C + D = 0.798 \text{ in.} + 4.792 \text{ in.} = 5.590 \text{ in.} \quad (2)$$

3.2.3 Dimension *F* is the Sales Code height decimal equivalent minus 0.300 in.. This conversion includes the double seam width or height of both top and bottom double seams, as well as, the 0.020-in. height reduction from our *D* Dimension determination.

$$F = 4.812 \text{ in.} - 0.300 \text{ in.} = 4.512 \text{ in.} \quad (3)$$

3.3 In all tables, the guidelines refer to Fig. 1 and Fig. 2, which illustrate the dimensions. Table 3 and Table 4 give straight-wall aerosol can height and curl dimensions. Table 5 and Table 6 give comparable information for necked-in aerosol cans.

### 4. Overcap Fit Dimensions

4.1 Table 7 provides the dimensions of top end and body which are critical for overcap fit.

### 5. Keywords

5.1 aerosol cans; specifications for tin-plate aerosol cans; tin-plate aerosol cans

**TABLE 3 Straight-Wall Aerosol Cans Guideline Dimensions (Inches)**

| Nominal Can Size | A<br>±0.004 | B<br>±0.010 | C<br>±0.016 | D<br>±0.031 | E<br>±0.035 | F<br>(minimum) | G<br>±0.007 |
|------------------|-------------|-------------|-------------|-------------|-------------|----------------|-------------|
| 202 by 214       | 1.000       | 1.221       | 0.396       | 2.855       | 3.251       | 2.575          | 0.130       |
| 202 by 306       | 1.000       | 1.221       | 0.396       | 3.355       | 3.751       | 3.075          | 0.130       |
| 202 by 314       | 1.000       | 1.221       | 0.396       | 3.855       | 4.251       | 3.575          | 0.130       |
| 202 by 406       | 1.000       | 1.221       | 0.396       | 4.355       | 4.751       | 4.075          | 0.130       |
| 202 by 505       | 1.000       | 1.221       | 0.396       | 5.293       | 5.689       | 5.013          | 0.130       |
| 202 by 509       | 1.000       | 1.221       | 0.396       | 5.542       | 5.938       | 5.262          | 0.130       |
| 202 by 700       | 1.000       | 1.221       | 0.396       | 6.980       | 7.376       | 6.700          | 0.130       |
| 202 by 709       | 1.000       | 1.221       | 0.396       | 7.480       | 7.876       | 7.200          | 0.130       |
| 207.5 by 509     | 1.000       | 1.221       | 0.798       | 5.542       | 6.341       | 5.262          | 0.130       |
| 207.5 by 605     | 1.000       | 1.221       | 0.798       | 6.292       | 7.090       | 6.012          | 0.130       |
| 207.5 by 701     | 1.000       | 1.221       | 0.798       | 7.042       | 7.840       | 6.676          | 0.130       |
| 207.5 by 703     | 1.000       | 1.221       | 0.798       | 7.168       | 7.966       | 6.888          | 0.130       |
| 207.5 by 708     | 1.000       | 1.221       | 0.798       | 7.480       | 8.278       | 7.200          | 0.130       |
| 207.5 by 713     | 1.000       | 1.221       | 0.798       | 7.792       | 8.590       | 7.512          | 0.130       |
| 211 by 413       | 1.000       | 1.221       | 0.798       | 4.792       | 5.590       | 4.512          | 0.130       |
| 211 by 600       | 1.000       | 1.221       | 0.798       | 5.980       | 6.778       | 5.700          | 0.130       |
| 211 by 604       | 1.000       | 1.221       | 0.798       | 6.230       | 7.028       | 5.950          | 0.130       |
| 211 by 612       | 1.000       | 1.221       | 0.798       | 6.730       | 7.528       | 6.450          | 0.130       |
| 211 by 713       | 1.000       | 1.221       | 0.798       | 7.792       | 8.590       | 7.512          | 0.130       |
| 211 by 908       | 1.000       | 1.221       | 0.798       | 9.480       | 10.278      | 9.200          | 0.130       |
| 300 by 709       | 1.000       | 1.221       | 0.798       | 7.542       | 8.340       | 7.262          | 0.130       |

**TABLE 4 Straight-Wall Aerosol Cans Guideline Dimensions (Millimetres)**

| Nominal Can Size | A<br>±0.10 | B<br>±0.25 | C<br>±0.41 | D<br>±0.79 | E<br>±0.89 | F<br>(minimum) | G<br>±0.18 |
|------------------|------------|------------|------------|------------|------------|----------------|------------|
| 52 by 73         | 25.40      | 31.01      | 9.40       | 72.52      | 82.58      | 65.41          | 3.30       |
| 52 by 85         | 25.40      | 31.01      | 9.40       | 85.22      | 95.28      | 78.11          | 3.30       |
| 52 by 98         | 25.40      | 31.01      | 9.40       | 97.92      | 107.98     | 90.81          | 3.30       |
| 52 by 111        | 25.40      | 31.01      | 9.40       | 110.62     | 120.68     | 103.51         | 3.30       |
| 52 by 134        | 25.40      | 31.01      | 9.40       | 134.43     | 144.49     | 127.32         | 3.30       |
| 52 by 141        | 25.40      | 31.01      | 9.40       | 140.78     | 150.84     | 133.67         | 3.30       |
| 52 by 177        | 25.40      | 31.01      | 9.40       | 177.29     | 187.35     | 170.18         | 3.30       |
| 52 by 190        | 25.40      | 31.01      | 9.40       | 189.99     | 200.05     | 182.88         | 3.30       |
| 60 by 141        | 25.40      | 31.01      | 20.27      | 140.78     | 161.05     | 133.67         | 3.30       |
| 60 by 160        | 25.40      | 31.01      | 20.27      | 159.83     | 180.10     | 152.72         | 3.30       |
| 60 by 179        | 25.40      | 31.01      | 20.27      | 178.88     | 199.15     | 171.77         | 3.30       |
| 60 by 182        | 25.40      | 31.01      | 20.27      | 182.05     | 202.32     | 174.94         | 3.30       |
| 60 by 190        | 25.40      | 31.01      | 20.27      | 189.99     | 210.26     | 182.88         | 3.30       |
| 60 by 198        | 25.40      | 31.01      | 20.27      | 197.93     | 218.20     | 190.82         | 3.30       |
| 65 by 122        | 25.40      | 31.01      | 20.27      | 121.72     | 141.99     | 114.62         | 3.30       |
| 65 by 152        | 25.40      | 31.01      | 20.27      | 151.89     | 172.16     | 144.62         | 3.30       |
| 65 by 158        | 25.40      | 31.01      | 20.27      | 158.24     | 178.51     | 151.13         | 3.30       |
| 65 by 171        | 25.40      | 31.01      | 20.27      | 170.94     | 191.21     | 163.83         | 3.30       |
| 65 by 198        | 25.40      | 31.01      | 20.27      | 197.93     | 218.20     | 190.82         | 3.30       |
| 65 by 241        | 25.40      | 31.01      | 20.27      | 240.79     | 261.06     | 233.68         | 3.30       |
| 73 by 192        | 25.40      | 31.01      | 20.27      | 191.58     | 211.85     | 184.47         | 3.30       |