

---

---

**Laminated veneer lumber —  
Measurement of dimensions and  
shape — Method of test**

*Lamibois — Mesurage des dimensions et forme — Méthode d'essai*

**iTeh STANDARD PREVIEW**  
**(standards.iteh.ai)**

[ISO 27567:2009](https://standards.iteh.ai/catalog/standards/sist/adfbf3ad-0342-48e6-a44f-30df27d58e2b/iso-27567-2009)

<https://standards.iteh.ai/catalog/standards/sist/adfbf3ad-0342-48e6-a44f-30df27d58e2b/iso-27567-2009>



**PDF disclaimer**

This PDF file may contain embedded typefaces. In accordance with Adobe's licensing policy, this file may be printed or viewed but shall not be edited unless the typefaces which are embedded are licensed to and installed on the computer performing the editing. In downloading this file, parties accept therein the responsibility of not infringing Adobe's licensing policy. The ISO Central Secretariat accepts no liability in this area.

Adobe is a trademark of Adobe Systems Incorporated.

Details of the software products used to create this PDF file can be found in the General Info relative to the file; the PDF-creation parameters were optimized for printing. Every care has been taken to ensure that the file is suitable for use by ISO member bodies. In the unlikely event that a problem relating to it is found, please inform the Central Secretariat at the address given below.

**iTeh STANDARD PREVIEW**  
**(standards.iteh.ai)**

ISO 27567:2009

<https://standards.iteh.ai/catalog/standards/sist/adfb3ad-0342-48e6-a44f-30d27d58e2b/iso-27567-2009>



**COPYRIGHT PROTECTED DOCUMENT**

© ISO 2009

All rights reserved. Unless otherwise specified, no part of this publication may be reproduced or utilized in any form or by any means, electronic or mechanical, including photocopying and microfilm, without permission in writing from either ISO at the address below or ISO's member body in the country of the requester.

ISO copyright office  
Case postale 56 • CH-1211 Geneva 20  
Tel. + 41 22 749 01 11  
Fax + 41 22 749 09 47  
E-mail [copyright@iso.org](mailto:copyright@iso.org)  
Web [www.iso.org](http://www.iso.org)

Published in Switzerland

## Foreword

ISO (the International Organization for Standardization) is a worldwide federation of national standards bodies (ISO member bodies). The work of preparing International Standards is normally carried out through ISO technical committees. Each member body interested in a subject for which a technical committee has been established has the right to be represented on that committee. International organizations, governmental and non-governmental, in liaison with ISO, also take part in the work. ISO collaborates closely with the International Electrotechnical Commission (IEC) on all matters of electrotechnical standardization.

International Standards are drafted in accordance with the rules given in the ISO/IEC Directives, Part 2.

The main task of technical committees is to prepare International Standards. Draft International Standards adopted by the technical committees are circulated to the member bodies for voting. Publication as an International Standard requires approval by at least 75 % of the member bodies casting a vote.

Attention is drawn to the possibility that some of the elements of this document may be the subject of patent rights. ISO shall not be held responsible for identifying any or all such patent rights.

ISO 27567 was prepared by Technical Committee ISO/TC 89, *Wood-based panels*, Subcommittee SC 3, *Plywood*.

## iTeh STANDARD PREVIEW (standards.iteh.ai)

[ISO 27567:2009](https://standards.iteh.ai/catalog/standards/sist/adfb3ad-0342-48e6-a44f-30d27d58e2b/iso-27567-2009)

<https://standards.iteh.ai/catalog/standards/sist/adfb3ad-0342-48e6-a44f-30d27d58e2b/iso-27567-2009>

**iTeh STANDARD PREVIEW**  
**(standards.iteh.ai)**

ISO 27567:2009

<https://standards.iteh.ai/catalog/standards/sist/adfb3ad-0342-48e6-a44f-30df27d58e2b/iso-27567-2009>

# Laminated veneer lumber — Measurement of dimensions and shape — Method of test

## 1 Scope

This International Standard describes the methods for determining the thickness, length, width, spring, bow, twist and section squareness and cupping of test pieces of structural laminated veneer lumber (LVL), as specified in ISO 18776.

## 2 Normative references

The following referenced documents are indispensable for the application of this document. For dated references, only the edition cited applies. For undated references, the latest edition of the referenced document (including any amendments) applies.

ISO 2074, *Plywood — Vocabulary*

ISO 18776, *Laminated veneer lumber (LVL) — Specifications*

ISO 16979, *Wood-based panels — Determination of moisture content*

<https://standards.iteh.ai/catalog/standards/sist/adfbf3ad-0342-48e6-a44f-30d27d58e2b/iso-27567-2009>

## 3 Terms and definitions

For the purposes of this document, the terms and definitions given in ISO 2074 apply.

## 4 Moisture content

To meet the requirements of this International Standard, the test pieces shall have a moisture content of  $(10 \pm 4)$  % as determined in accordance with ISO 16979.

## 5 Apparatus

### 5.1 Determination of thickness.

5.1.1 **Suitable linear measuring instrument**, i.e. a screw micrometer.

5.1.2 **Vernier calipers** or **dial gauge**, having flat and parallel measuring surfaces with a contact area of between 30 mm<sup>2</sup> and 300 mm<sup>2</sup>, reading to an accuracy of 0,1 mm.

### 5.2 Determination of length and width.

5.2.1 **Suitable linear measuring instrument**, reading to an accuracy of 0,5 mm.

**5.3 Determination of spring.**

**5.3.1 Thumbtacks or drawing pins**, at least two, or **staple gun and staples**.

**5.3.2 Blocks**, two, with flat surfaces, for which the difference in thickness does not exceed 0,1 mm.

NOTE Blocks of 30 mm × 15 mm × 20 mm have been found to be suitable.

**5.3.3 Wire or cord**, strong and thin.

**5.3.4 Suitable linear measuring instrument**, reading to an accuracy of 0,5 mm.

**5.4 Determination of bow.**

**5.4.1 Surface**, nominally flat, near horizontal, larger than the piece by at least 25 mm in each direction.

**5.4.2 Suitable linear measuring instrument**, reading to an accuracy of 0,5 mm.

**5.4.3 Masses**, totalling  $(85 \pm 5)$  kg.

**5.5 Determination of twist.**

**5.5.1 Surface**, nominally flat, near horizontal, larger than the piece by at least 25 mm in each direction.

**5.5.2 Suitable linear measuring instrument**, reading to an accuracy of 0,5 mm.

**5.6 Determination of squareness of section.**

**5.6.1 Square**, with legs at least 25 mm longer than the width of the test piece to be measured, with the tolerance for out-of-squareness of the legs of the square being 1 mm/m.

**5.6.2 Suitable linear measuring device**, capable of measuring gaps to an accuracy of 0,1 mm.

**5.7 Determination of cupping.**

**5.7.1 Linear measuring device**, capable of measuring gaps to an accuracy of 0,1 mm.

**5.7.2 Straight edge.**

**6 Procedure**

**6.1 General**

The moisture content of the piece shall be determined in accordance with Clause 4.

**6.2 Determination of thickness**

The thickness of the piece shall be measured at six places, one approximately in the middle of each long side and approximately 25 mm from the edges, and one at each corner approximately 25 mm in from the edge and 200 mm in from the end (see Figure 1).

The measuring instrument (5.1.1) shall be read to the nearest 0,1 mm, and the readings recorded.

Dimensions in millimetres

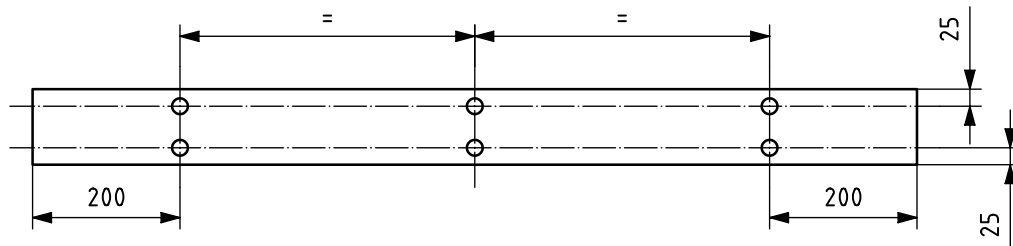

Figure 1 — Location of measuring points for thickness

### 6.3 Determination of length and width

The length and width of the piece shall be measured to the nearest 1 mm, along both long sides and both ends, i.e. two measurements each for length and width. The measurements shall then be recorded.

### 6.4 Determination of spring

Lay the piece to be checked on a flat surface.

Take the measurement on the concave edge of the piece (see Figure 2).

Attach the wire or cord (5.3.3) to one end of the piece with a thumbtack or staple (5.3.1).

Place the blocks (5.3.2) on the edge to be measured and at each end of the piece.

Pull the wire or cord around one corner, over both blocks and around the other corner.

Attach the loose end of the wire or cord to the other end of the piece with a thumbtack or staple, so that the wire or cord is held taut.

Measure the perpendicular distance between the wire or cord and the midpoint of the piece at the centre of the edge, to the nearest 0,5 mm.

Record the deviation from straightness, i.e. the spring, as the difference between the measurement of the perpendicular distance between the wire or cord and the midpoint of the piece at the centre of the edge, and the average thickness of the blocks.

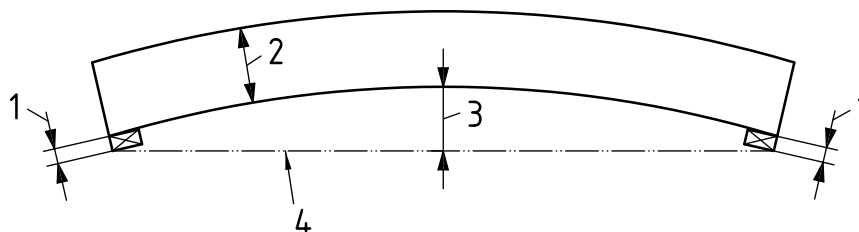

#### Key

- 1 block thickness
- 2 width
- 3 perpendicular distance between wire and midpoint of piece
- 4 wire or cord

Figure 2 — Measurement of spring (plan view)

### 6.5 Measurement of bow

Place the piece on the nominally flat, near horizontal surface (5.4.1) with convex face up, as shown in Figure 3.

Place the load (5.4.3) of  $(85 \pm 5)$  kg on the centre of the piece.

Measure the maximum distance, if any, between the nominally flat surface and the underside of the piece. Make allowance, if necessary, in the measurement for the out-of-flatness of the nominally flat surface.

Record the measurement to the nearest 0,5 mm.

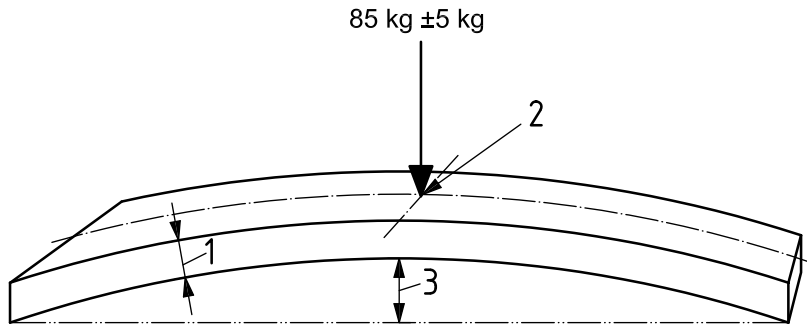

- Key**
- 1 thickness
  - 2 centre of piece
  - 3 bow

iTeh STANDARD PREVIEW  
(standards.iteh.ai)

Figure 3 — Measurement of bow

<https://standards.iteh.ai/catalog/standards/sist/adfb3ad-0342-48e6-a44f-30d27d58e2b/iso-27567-2009>

### 6.6 Measurement of twist

Place the piece on the nominally flat, near horizontal surface (5.5.1), with three corners in contact with the surface, as shown in Figure 4.

Measure the distance, if any, between the fourth corner of the piece and the nominally flat surface. Make allowance, if necessary, in the measurement for the out-of-flatness of the nominally flat surface.

Record the measurement to the nearest 0,5 mm.

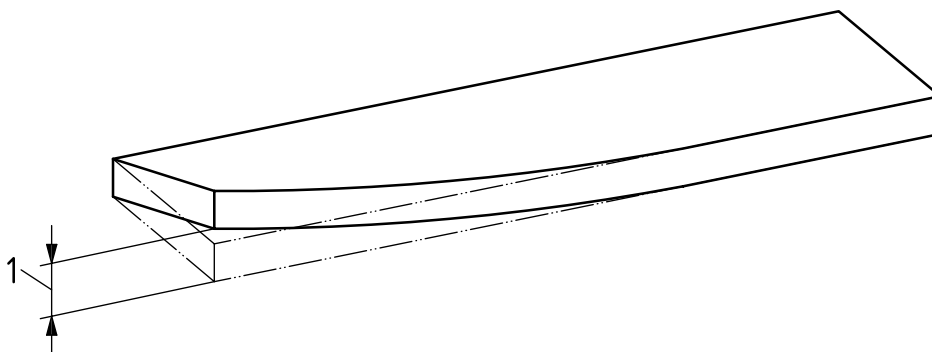

- Key**
- 1 twist

Figure 4 — Measurement of twist



## 6.7 Measurement of squareness of section

The squareness of section shall be measured at three positions along the edge to be checked; one approximately in the middle and the others 200 mm from each end of the piece.

Place the square (5.6.1) on the edge to be checked, so that one leg of the square is butted firmly against the edge (see Figure 5).

Measure the gap, if any, between the face at the opposite edge of the piece and the other leg of the square.

Record the measurements to the nearest 0,1 mm.

Dimensions in millimetres

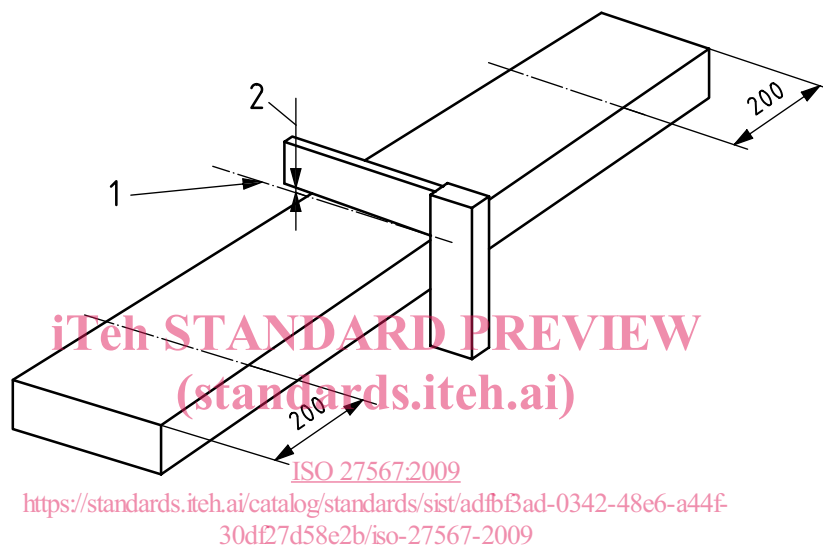

### Key

- 1 centreline
- 2 gap

**Figure 5 — Measurement of squareness of section**

## 6.8 Measurement of cupping

Cupping shall be measured at three positions along the surface to be checked; one approximately in the middle and the others 200 mm from each end of the piece.

Place a straight edge (5.7.2) across the surface to be checked, at right angles to the long edge of the piece so that it touches both edges of the piece (see Figure 6).

Measure the gap, if any, between the straight edge and the surface of the test piece on the centreline of the piece.

Record the measurement to the nearest 0,1 mm.

At the time of measurement the maximum moisture content gradient through the thickness of the test piece shall be 1 %.