



Designation: D6395 – 05

Standard Test Method for Flatwise Flexural Impact Resistance of Rigid Plastics¹

This standard is issued under the fixed designation D6395; the number immediately following the designation indicates the year of original adoption or, in the case of revision, the year of last revision. A number in parentheses indicates the year of last reapproval. A superscript epsilon (ϵ) indicates an editorial change since the last revision or reapproval.

1. Scope*

1.1 The resistance of plastics to breakage by flexural shock may be determined by test methods such as those contained in Test Method [D256](#). Specimens used in those test methods feature a milled notch to promote brittle fracture. The test specimens are struck by a pendulum with the depth dimension parallel to the direction of pendulum swing. This test method is differentiated from the others by its application to the assessment of the effect on impact resistance of changes in the surface of specimens resulting from weathering or other exposure. In this test method, specimens are struck by a pendulum with the depth dimension perpendicular to the direction of pendulum swing. Test Method [D5420](#) may also be used to conduct testing of weathered or exposed specimens. This test method is differentiated from Gardner Impact by the smaller size of the specimens, which may result in substantially higher productivity of accelerated weathering instruments. Additionally, this test method provides multiple data from a single specimen for characterization of within specimen variability.

1.2 This test method describes the determination of the resistance of rigid plastic strip specimens to breakage or permanent deformation when one end of the specimen is subjected to an impact upon its wide face while the other end of the specimen is firmly clamped.

1.3 This test method is applicable to specimens of 1.60 mm [0.0625 in.] thickness. However, the limits of applicability of the test are not sharply defined, and specimens having other dimensions may frequently be used. For specimens of thicknesses other than 1.60 mm [0.0625 in.] the ratio of the distance between the top of the clamp and the centerline of the rounded striking edge to the specimen thickness must be 2.5 ± 0.1 .

1.4 This test method measures the relative impact resistance of samples having approximately the same thickness. Normalization of the impact resistance to unit cross-sectional area only partly compensates for the effects of specimen thickness variation because, at the fixed cantilever length, the ratio of shear stress to tensile stress in bending increases with thick-

ness, and the importance of these effects in contributing to the energy absorbed is greater for ductile than for brittle failure.

1.5 This test method is used primarily as a means of assessing, for a series of samples, changes relative to a control due to some treatment such as weathering or exposure to active environments. It has been particularly useful as a sensitive indicator of the development of surface cracks or a brittle surface. The existence or formation of cracks in an inherently brittle surface produces marked lowering of impact strength when that surface is the one subjected to tension in the test.

1.6 This test method is not generally applicable to materials such as elastomers or nonrigid plastics in which there is no fracture, permanent deformation, or other change due to yielding in flexure. However, it may be desirable to test such materials as file samples to establish reference points when the test is applied as described in [1.5](#).

1.7 The values stated in SI units are to be regarded as the standard. The values given in brackets are for information only.

1.8 *This standard does not purport to address all of the safety concerns, if any, associated with its use. It is the responsibility of the user of this standard to establish appropriate safety and health practices and determine the applicability of regulatory limitations prior to use.*

NOTE 1—There is no equivalent or similar ISO standard.

2. Referenced Documents

2.1 ASTM Standards:²

[D256](#) Test Methods for Determining the Izod Pendulum Impact Resistance of Plastics

[D618](#) Practice for Conditioning Plastics for Testing

[D883](#) Terminology Relating to Plastics

[D5420](#) Test Method for Impact Resistance of Flat, Rigid Plastic Specimen by Means of a Striker Impacted by a Falling Weight (Gardner Impact)

[D5947](#) Test Methods for Physical Dimensions of Solid Plastics Specimens

3. Terminology

3.1 Definitions used in this test method are in accordance with Terminology [D883](#).

¹ This test method is under the jurisdiction of ASTM Committee [D20](#) on Plastics and is the direct responsibility of Subcommittee [D20.10](#) on Mechanical Properties.

Current edition approved Nov. 1, 2005. Published December 2005. Originally approved in 1999. Last previous edition approved in 1999 as D6395 - 99. DOI: 10.1520/D6395-05.

² For referenced ASTM standards, visit the ASTM website, www.astm.org, or contact ASTM Customer Service at service@astm.org. For *Annual Book of ASTM Standards* volume information, refer to the standard's Document Summary page on the ASTM website.

*A Summary of Changes section appears at the end of this standard.

4. Significance and Use

4.1 The flatwise flexural impact test is a test in which the kinetic energy lost by a moving pendulum during impact is used to determine the energy to break or deform a test specimen.

4.2 The standard Izod test apparatus as described in Test Method **D256** is retrofitted with clamping jaws, which hold the test specimen such that the flat face of the specimen is struck by the pendulum during a test.

4.3 The pendulum shall be a standard Izod pendulum as described in Test Method **D256**. It shall be capable of delivering an energy of 2.71 ± 0.14 J [2.00 ± 0.10 ft.-lbf]. Except as detailed in **10.5**, this basic pendulum shall be used with all specimens that extract less than 85 % of the available energy. Higher energy pendulums or a basic pendulum to which weights are added to increase its available energy shall be used with specimens that require more energy to break. A series of energy levels such that each has twice the energy of the next lighter one will be found convenient. The striking nose of the pendulum shall contact one of the flat faces of the specimen at a specified distance above the clamp edge. The ratio of the distance between the top of the clamp and the centerline of the rounded striking edge to the specimen thickness shall be 2.5 ± 0.1 .

4.4 The type of failure of each specimen tested shall be assigned one of the following categories:

Complete Break (C)—A break in which the specimen is separated into two or more pieces.

Hinge Break (H)—A nearly complete break in which there is little or no spring back when the free end is bent or displaced.

Partial Break (P)—An incomplete break in which fracture extends through at least 50 % of the specimen thickness, and such that the free end can be bent with relatively little effort yet has considerable spring back.

Nonbreak (N)—A result where there is no fracture or the fracture extends less than 50 % of the specimen thickness.

4.5 The value of this impact test is to determine the change in impact properties that may result from a material having been exposed to one or a series of environments, such as weathering at different intervals or different intensities when these data are compared to a file sample exposed only to the standard laboratory environment or other agreed upon conditions.

4.6 The flatwise impact resistance is calculated as energy absorbed per unit of cross-sectional area.

4.7 Before proceeding with this test method, reference should be made to the specification of the material being tested. Any test specimen preparation, conditioning, dimensions, and/or testing parameters covered in the material specification shall take precedence over those mentioned in this test method except in cases where to do so would conflict with the purpose for conducting testing. If there are no material specifications, then the default conditions apply.

5. Interferences

5.1 Use of an improper shim will result in test values either too large or too small depending upon whether the shim in use is too short or too long.

5.2 Orientation and molded-in stresses due to flow and cooling history result in variation in properties within injection molded specimen, especially at the ends and at the gate region. The effects of such variations can be minimized by avoiding tests close to the gate or the ends of the specimen.

5.3 The clearance between the pendulum and the clamp as the pendulum passes the clamp at its closest point during a test significantly affects the results of this test. If the specimen thickness is greater than about one half of the clearance, a large energy loss due to friction occurs in ductile specimens. The ratio of shear to surface tensile stress increases and the nature of failure may change abruptly over a narrow range of specimen thickness. The clearance is dictated by the ratio of the distance between the pendulum nose centerline and the clamp top to the specimen thickness (2.5 ± 0.1). The movable jaw face and fixed jaw face set used for the thickness of specimen being tested shall either be of proper dimensions for this ratio or be adjustable in design to allow the ratio to be achieved.

5.4 The use of excessive clamping force may induce stresses in test specimens causing variation in test results.

6. Apparatus

6.1 *Testing Machine*—The testing machine shall consist of the standard Izod test instrument as detailed in Test Method **D256** but with a modified clamping arrangement. **Figs. 1-3** illustrate typical clamping arrangements applicable to some instruments. Other clamping arrangements may be used provided that they maintain the specified ratio of the distance between the top of the clamp and the centerline of the pendulum nose to the specimen thickness (2.5 ± 0.1). Other arrangements must also provide uniform clamping along the clamped length of the specimen and position the specimen such that when the pendulum is freely hanging, the striking edge is within 0.2 % of full scale of touching the front face of the specimen as required by Test Method **D256**. As indicated by these figures, the specimen clamp faces may be bolted or otherwise firmly attached to the existing Izod fixed and movable jaws. To avoid compromising the instrument's capability for Izod testing, using either a dedicated set of fixed and movable Izod jaws or clamping faces mounted in such a way as to not alter the existing Izod jaws is recommended.

6.2 *Specimen Clamp Faces*—Special clamp faces (see **Fig. 2**) for both the fixed and the movable jaws of the clamp shall be used to clamp the test specimen flatwise with its long axis vertical and its thickness direction parallel to the direction of the pendulum swing. The clamp faces constitute a set. Some dimensions within the set are dictated by the thickness of the specimen being tested and by the particular Izod instrument being used. **Fig. 2** provides the dimensions for clamp faces when used with one type of Izod instrument to test 1.60 mm [0.062 in.] thick specimen.

6.2.1 For 1.60 mm [0.062 in.] thick specimens the distance between the upper edge of the clamp and the striking nose of the pendulum is 4.0 mm [0.161 in.] providing a clearance between the clamp and the lowest part of the pendulum's striking nose of 3.20 mm [0.126 in.].

NOTE 2—The required dimensions of hardware may vary from those provided in the figures as a result of individual tolerances necessary to

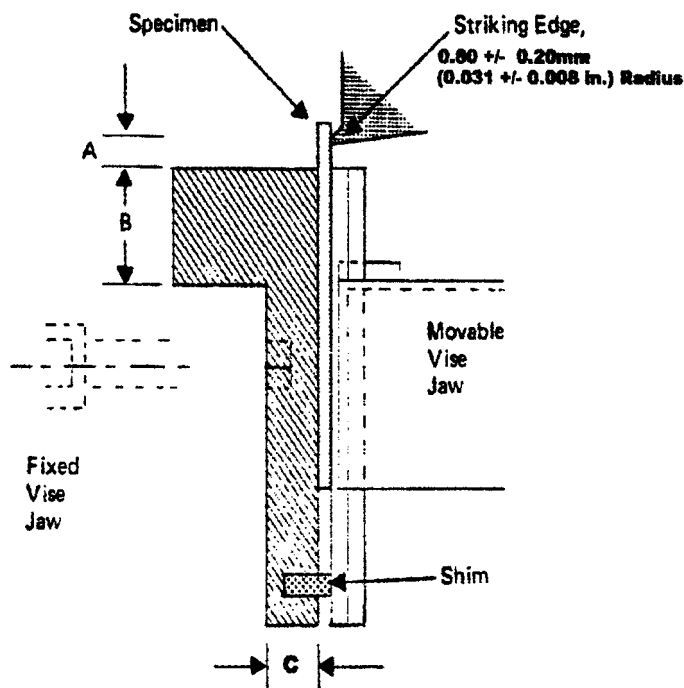

Dimensions

- A = 4.00 mm [0.161 in.] for 1.60 mm [0.062 in.] thick specimen.
- B = The value of dimension B is determined by the particular Izod instrument used. Select dimension B as required to achieve dimension A for the specimen thickness being tested.
- C = The value of dimension C is determined by the thickness of the specimen to be tested. It is calculated by subtracting the specimen thickness from 12.7 mm [0.5 in.].

Legend

- A = Distance between clamp top and center line of rounded striking edge,
- B = Height of clamp top above fixed jaw of vise, and
- C = Thickness of fixed jaw face.

FIG. 1 Typical Specimen Clamping Device

mate with preexisting components. The cumulative tolerances of individual hardware components must result in the required ratio of the distance between the top of the clamp and the centerline of the rounded striking edge to the specimen thickness of 2.5 ± 0.1 .

6.3 *Shims*—A set of steel blocks (see Fig. 3) shall be used to provide spacing between the lower end of the jaw faces to keep the faces as parallel as possible during testing. A shim shall be selected to provide a spacing between the clamp faces matched as closely as possible to the thickness of the specimen being tested. In no case shall the shim protrude beyond the jaw face by less than the specimen thickness or insufficient clamping of the specimen may result. Fig. 3 provides the dimensions for a set of shims spanning a typical range of thickness for the testing of 1.60 mm [0.0625 in.] thick specimen.

6.4 *Micrometers*—Suitable micrometers with a resolution of 0.025 mm [0.001 in.] or better shall be used to measure the thickness of the test specimen. The micrometer shall conform to the applicable provisions of Test Method D5947.

7. Sampling, Test Specimen, and Test Units

7.1 The standard test specimen shall have a rectangular cross-section and an approximate length of 65 mm [2.5 in.]. Most specimens should be 12.7 mm [0.500 in.] wide by 1.60

mm [0.0625 in.] thick, but for some materials, such as those which are glass reinforced, it may be desirable to use specimens of other thicknesses. The specimens may be molded or cut from flat sheet, but they shall be of uniform dimensions within any given set.

7.2 Trim or sand off any protrusions that might interfere with clamping or positioning the specimen in the instrument clamps. Do not introduce notches or scratches in the test face of the specimen.

7.3 Injection-molded specimens shall have at least 6 mm [0.25 in.] cut from the end to be tested first so that when the specimen is clamped in the testing machine, the clamp edge will be no less than 12 mm [0.5 in.] from the original end of the specimen. The clamp edge shall also be at least 6 mm [0.25 in.] from a gate. Whenever this test is used for assessing aging effects, cut off any portion of the test specimen end which has not been uniformly exposed to the aging environment so that the edge of the clamp will be at least 6 mm [0.25 in.] from the unexposed region.

8. Calibration and Standardization

8.1 Check the flatwise impact tester periodically for conformance to the provisions of Test Method D256.

8.2 The proper movable jaw face, fixed jaw face, and shim shall be installed for the thickness of the specimen being tested. The dimensional relationships between the various combinations of hardware components for a 1.60 mm [0.0625 in.] thick specimen is provided in Fig. 1.

8.3 The clearance between the pendulum and the upper grip surface at their closest point shall be checked frequently to confirm that the correct clearance is being used for the thickness of the specimen being tested and that the clearance plus striker radius meets the required ratio.

8.4 Adequate file samples for each group of treated samples shall be tested, preferably at the same time that the treated samples are tested.

9. Conditioning

9.1 *Conditioning*—Condition the test specimens at $23 \pm 2^\circ\text{C}$ [$73.4 \pm 3.6^\circ\text{F}$] and $50 \pm 5\%$ relative humidity for not less than 40 h prior to test in accordance with Procedure A of Practice D618, unless otherwise specified by contract or relevant material specification, or unless it has been shown that conditioning is not necessary. In cases of disagreement, the tolerances shall be 1°C [1.8°F] and $\pm 2\%$ relative humidity.

9.2 *Test Conditions*—Conduct tests in the standard laboratory atmosphere of $23 \pm 2^\circ\text{C}$ [$73.4 \pm 3.6^\circ\text{F}$] and $50 \pm 5\%$ relative humidity, unless otherwise specified by the contract or relevant material specification. In cases of disagreement, the tolerances shall be 1°C [1.8°F] and $\pm 2\%$ relative humidity.

10. Procedure

10.1 Test a minimum of two specimens. Measure and record the width and thickness of each specimen to the nearest 0.025 mm [0.001 in.] by taking a single width measurement and a single thickness measurement in the center of the longitudinal axis.

10.2 Select a movable jaw face and fixed jaw face set, shim appropriate to the thickness of the specimen being tested, and