



Standard Specification for Protective Headgear with Faceguard Used in Bull Riding¹

This standard is issued under the fixed designation F2530; the number immediately following the designation indicates the year of original adoption or, in the case of revision, the year of last revision. A number in parentheses indicates the year of last reapproval. A superscript epsilon (ϵ) indicates an editorial change since the last revision or reapproval.

INTRODUCTION

Bull riding is a sport with intrinsic hazards. It is recognized that it is not possible to write a protective headgear with faceguard standard specification that will result in headgear with faceguards that can protect against injury or death in all accidents. Because of complex interactions of variables such as bull motion, bull size and weight, rider size, direction and point of impact, and individual differences in reaction to impact forces, it must be kept in mind that injuries are still possible. It is also recognized that serious injury or death can result from both low-energy and high-energy impacts, even when protective headgear with faceguard is worn. It is further recognized that protective headgear with faceguards must be acceptable to the user and to the regulating associations or agencies requiring its use.

In bull riding, where the force of impact between the bull and the face of the rider can cause head and facial injury, there is a need for both head and facial protection. After careful consideration of the mechanisms and forces involved in this context, this standard specification for headgear with faceguards has been prepared, using resources in medical, scientific, mechanical engineering, human factors, and biomechanical fields.

This specification is a series of laboratory tests of the protective headgear with faceguard. The headgear testing measures its ability to reduce head acceleration when impacting various shaped objects. The faceguard testing checks its ability to limit contact with the user face to reduce the potential for facial injuries.

This specification incorporates many aspects of other recognized headgear standard specifications.

Other intentions that were not amenable to testing or inspection are offered as guidelines:

(1) The chin strap should be attached in a manner to enable the headgear with faceguard to remain in its normal position on the wearer's head during bull riding and impact conditions;

(2) The physical characteristics of materials used in construction of the headgear with faceguard should retain their shock-absorbing characteristics under the influence of aging, use, or exposure to typical environmental conditions;

(3) The faceguard should not significantly interfere with the vision of the wearer; and

(4) In the event of injury, the headgear with faceguard should be removable without causing movement to the cervical spine. The access provided shall be sufficient for the administration of cardiopulmonary resuscitation to the wearer.

1. Scope

1.1 This specification covers performance requirements and describes test methods for protective headgear with faceguards for use in bull riding.

1.2 All testing and requirements of this specification shall be in accordance with Test Methods F1446, except where noted herein.

1.3 Partial utilization of this specification is prohibited. Any statement of compliance with this specification shall be a certification that the headgear with faceguard meets all of the requirements of the specification in their entirety. A headgear with faceguard that fails to meet any one of the requirements of this specification is considered to have failed the specification, and shall not be sold with any indication that it meets parts of the specification.

1.4 Headgear with faceguards designed to comply with this and other standards may proclaim uses as certified by the manufacturer.

1.5 The values stated in SI units are to be regarded as standard.

¹ This specification is under the jurisdiction of ASTM Committee F08 on Sports Equipment and Facilities and is the direct responsibility of Subcommittee F08.53 on Headgear and Helmets.

Current edition approved Nov. 15, 2005. Published December 2005. DOI: 10.1520/F2530-05.

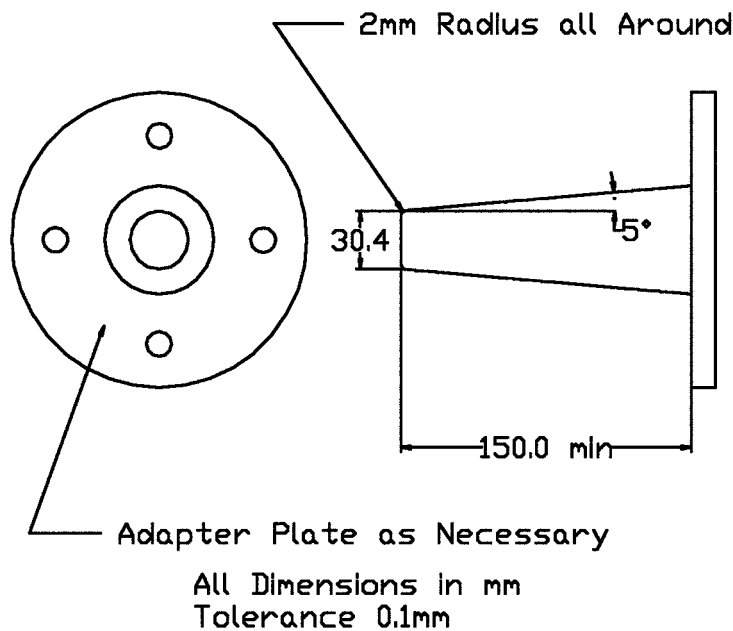

FIG. 1 Simulated Horn

1.6 This standard does not purport to address all of the safety concerns, if any, associated with its use. It is the responsibility of the user of this standard to establish appropriate safety and health practices and determine the applicability of regulatory limitations prior to use.

2. Referenced Documents

2.1 *ASTM Standards*:²

F910 Specification for Face Guards for Youth Baseball

F1163 Specification for Protective Headgear Used in Horse Sports and Horseback Riding

F1446 Test Methods for Equipment and Procedures Used in Evaluating the Performance Characteristics of Protective Headgear

F2220 Specification for Headforms

2.2 *NOCSAE Document*:³

NOCSAE DOC.001 Standard Drop Test Method and Equipment used in Evaluating the Performance Characteristics of Protective Headgear

3. Terminology

3.1 Definitions as identified in Test Methods **F1446**.

3.2 *Definition of Term Specific to This Standard*:

3.2.1 *simulated horn*—a rigid metal rod that is a conservative representation of a bull's horn.

4. Significance and Use

4.1 The purpose of this specification is to provide reliable and repeatable test methods for the evaluation of headgear with faceguards for bull riding. Headgear with faceguards satisfying this specification are intended to reduce forces reaching the head in some of the impacts that may occur in bull riding and to limit contact with the facial features of the rider.

5. Certification

5.1 This specification permits self-certification. It is recommended that each manufacturer employ an independent test laboratory at least annually to test each model and size of headgear with faceguard offered for sale.

6. Apparatus

6.1 Apparatus used for this testing shall be in accordance with Test Methods **F1446** except as noted below.

6.2 *Reference or Full-facial Headform* to be used shall be as specified in:

6.2.1 The section on Other (Reference) Headforms of Specification **F2220**.

6.2.2 Standard drop test method and equipment used in evaluating the performance characteristics of protective headgear of **NOCSAE DOC.001**⁴

6.3 *Simulated Horn*—A rigid steel rod representative of a bull's horn, **Fig. 1**. The end of the rod is 30.4 mm (1.20 in.) in diameter, flat, and perpendicular to the axis of the rod with a 2 mm (0.08 in.) radius round. There is a 5° taper along the length of the rod with the diameter increasing. The overall length of the rod shall be at least 15 cm (6.0 in.) long. The hardness of the rod shall be Brinell Hardness 200 or greater.

² For referenced ASTM standards, visit the ASTM website, www.astm.org, or contact ASTM Customer Service at service@astm.org. For *Annual Book of ASTM Standards* volume information, refer to the standard's Document Summary page on the ASTM website.

³ Available from NOCSAE, P.O. Box 12290, Overland, KS 66282-2290, or www.nocsae.org.

⁴ The sole source of supply of the NOCSAE headforms known to the committee at this time is Southern Impact Research Center, 304 Dunavant Drive, Rockford, TN 37853. If you are aware of alternative suppliers, please provide this information to ASTM International Headquarters. Your comments will receive careful consideration at a meeting of the responsible technical committee,¹ which you may attend.