**Rubber latex, synthetic — Determination
of mechanical stability —**

Part 2:

Moderate-speed method under load

*Latex de caoutchouc synthétique — Détermination de la stabilité
mécanique —*

Partie 2: Méthode à vitesse modérée sous charge

iteh Standards
(<https://standards.iteh.ai>)
Document Preview

ISO 2006-2:2009

<https://standards.iteh.ai/catalog/standards/iso/a477da4f-cec6-49af-b9f1-ab58202d8c35/iso-2006-2-2009>



PDF disclaimer

This PDF file may contain embedded typefaces. In accordance with Adobe's licensing policy, this file may be printed or viewed but shall not be edited unless the typefaces which are embedded are licensed to and installed on the computer performing the editing. In downloading this file, parties accept therein the responsibility of not infringing Adobe's licensing policy. The ISO Central Secretariat accepts no liability in this area.

Adobe is a trademark of Adobe Systems Incorporated.

Details of the software products used to create this PDF file can be found in the General Info relative to the file; the PDF-creation parameters were optimized for printing. Every care has been taken to ensure that the file is suitable for use by ISO member bodies. In the unlikely event that a problem relating to it is found, please inform the Central Secretariat at the address given below.

iTeh Standards
(<https://standards.iteh.ai>)
Document Preview

ISO 2006-2:2009

<https://standards.iteh.ai/catalog/standards/iso/a477da4f-cec6-49af-b9f1-ab58202d8c35/iso-2006-2-2009>



COPYRIGHT PROTECTED DOCUMENT

© ISO 2009

All rights reserved. Unless otherwise specified, no part of this publication may be reproduced or utilized in any form or by any means, electronic or mechanical, including photocopying and microfilm, without permission in writing from either ISO at the address below or ISO's member body in the country of the requester.

ISO copyright office
Case postale 56 • CH-1211 Geneva 20
Tel. + 41 22 749 01 11
Fax + 41 22 749 09 47
E-mail copyright@iso.org
Web www.iso.org

Published in Switzerland

Contents

Page

Foreword	iv
Introduction	v
1 Scope	1
2 Normative references	1
3 Terms and definitions	1
4 Principle	1
5 Reagents	2
6 Apparatus	2
7 Sampling	8
8 Procedure	8
9 Expression of results	10
10 Test report	10
Annex A (informative) Precision	11
Bibliography	14

iTech Standards
<https://standards.itih.ai>
 Document Preview

ISO 2006-2:2009

<https://standards.itih.ai/catalog/standards/iso/a477da4f-cec6-49af-b9f1-ab58202d8c35/iso-2006-2-2009>

Foreword

ISO (the International Organization for Standardization) is a worldwide federation of national standards bodies (ISO member bodies). The work of preparing International Standards is normally carried out through ISO technical committees. Each member body interested in a subject for which a technical committee has been established has the right to be represented on that committee. International organizations, governmental and non-governmental, in liaison with ISO, also take part in the work. ISO collaborates closely with the International Electrotechnical Commission (IEC) on all matters of electrotechnical standardization.

International Standards are drafted in accordance with the rules given in the ISO/IEC Directives, Part 2.

The main task of technical committees is to prepare International Standards. Draft International Standards adopted by the technical committees are circulated to the member bodies for voting. Publication as an International Standard requires approval by at least 75 % of the member bodies casting a vote.

Attention is drawn to the possibility that some of the elements of this document may be the subject of patent rights. ISO shall not be held responsible for identifying any or all such patent rights.

ISO 2006-2 was prepared by Technical Committee ISO/TC 45, *Rubber and rubber products*, Subcommittee SC 3, *Raw materials (including latex) for use in the rubber industry*.

ISO 2006 consists of the following parts, under the general title *Rubber latex, synthetic — Determination of mechanical stability*:

- *Part 1: High-speed method*
- *Part 2: Moderate-speed method under load*

<https://standards.iteh.ai/>

<https://standards.iteh.ai/catalog/standards/iso/a477da4f-cec6-49af-b9f1-ab58202d8c35/iso-2006-2-2009>

Introduction

The mechanical stability of synthetic latices is important in a variety of manufacturing processes, and a number of empirical methods are used for testing. This part of ISO 2006 provides a method of determining the mechanical stability by stirring a latex test portion at a moderate speed under load with shear. It can provide a more accurate indication of latex performance by simulating the actual service conditions.

The design of the mechanical stability test machine utilized in this part of ISO 2006 was originally developed by Maron and Ulevitch^[1], and the mechanical stability of various latices has been studied. It has been concluded that the test is rapid and reliable.

iTeh Standards (<https://standards.iteh.ai>) Document Preview

[ISO 2006-2:2009](https://standards.iteh.ai/catalog/standards/iso/a477da4f-cec6-49af-b9f1-ab58202d8c35/iso-2006-2-2009)

<https://standards.iteh.ai/catalog/standards/iso/a477da4f-cec6-49af-b9f1-ab58202d8c35/iso-2006-2-2009>

Rubber latex, synthetic — Determination of mechanical stability —

Part 2: Moderate-speed method under load

WARNING — Persons using this part of ISO 2006 should be familiar with normal laboratory practice. This part of ISO 2006 does not purport to address all of the safety problems, if any, associated with its use. It is the responsibility of the user to establish appropriate safety and health practices and to ensure compliance with any national regulatory conditions.

1 Scope

This part of ISO 2006 specifies a method for the determination of the mechanical stability of synthetic rubber latex. This method measures the mass of coagulum formed when a test portion of latex is stirred for a specified length of time at moderate speed under a relatively high shear stress achieved by applying a load.

2 Normative references

The following referenced documents are indispensable for the application of this document. For dated references, only the edition cited applies. For undated references, the latest edition of the referenced document (including any amendments) applies.

ISO 123, *Rubber latex — Sampling*

ISO 124, *Latex, rubber — Determination of total solids content*

ISO 3310-1, *Test sieves — Technical requirements and testing — Part 1: Test sieves of metal wire cloth*

3 Terms and definitions

For the purposes of this document, the following terms and definitions apply.

3.1

mechanical stability

resistance to coagulation of latex when subjected to mechanical shear under specified conditions

NOTE The greater the percentage of coagulum formed (w_c as defined in Clause 9), the poorer the mechanical stability.

4 Principle

A test portion of latex is stirred at a moderate speed under load for a given time, and the coagulum formed is separated and weighed. The mass of coagulum formed is inversely proportional to the mechanical stability.

5 Reagents

During the analysis, use only carbonate-free distilled water or water of equivalent purity.

5.1 Surfactant solution: 5 % (by mass) solution of potassium oleate of pH value $10 \pm 0,5$ or, for use with a latex which is coagulated by potassium oleate solution, a 5 % (by mass) solution of a synthetic anionic or non-ionic surfactant.

6 Apparatus

6.1 Mechanical stability tester¹⁾, designed to rotate a disc attached to a spindle shaft at a constant stirring speed of $1\ 000\ \text{min}^{-1} \pm 20\ \text{min}^{-1}$ while applying a constant load to the latex container (6.2). The device shall be capable of maintaining a load of up to 500 N to within 2 N. An example of a tester is shown in Figure 1.

6.2 Latex container, comprising a flat-bottomed plate with a grooved pattern cut into it as shown in Figure 2, a polyethylene liner disc 1,6 mm thick with four holes as shown in Figure 3 and a cylindrical wall with flange assembled with the flat-bottomed plate as shown in Figures 4 and 5.

6.3 Rotating disc, consisting of a vertical stainless-steel shaft 9,5 mm in diameter attached to a disc (also made of stainless steel) with four grooves cut into it. Detailed dimensions are shown in Figure 6.

6.4 Preliminary filter, of stainless-steel wire cloth with an average aperture width of $180\ \mu\text{m} \pm 10\ \mu\text{m}$, complying with ISO 3310-1.

6.5 Test filter, consisting of a disc of stainless-steel wire cloth with an average aperture width of $180\ \mu\text{m} \pm 10\ \mu\text{m}$, complying with ISO 3310-1, dried to constant mass and weighed to the nearest 1 mg, firmly clamped between two stainless-steel rings of equal internal diameter between 25 mm and 50 mm.

Document Preview

[ISO 2006-2:2009](https://standards.iteh.ai/catalog/standards/iso/a477da4f-cec6-49af-b9f1-ab58202d8c35/iso-2006-2-2009)

<https://standards.iteh.ai/catalog/standards/iso/a477da4f-cec6-49af-b9f1-ab58202d8c35/iso-2006-2-2009>

1) Suitable instruments are available commercially, e.g. from Ueshima Seisakusho Co., Ltd., 1053-1 Yaho Kunitachi-shi, Tokyo 186-0011, Japan, Fax: +81-4-2573-1520, and Kumagai Riki Kogyo Co., Ltd., 2-4, Toyotama-kita 3-Chome, Nerima-ku, Tokyo 176-0012, Japan, Fax: +81-3-3994-0520. This information is given for the convenience of users of this part of ISO 2006 and does not constitute an endorsement by ISO of these instruments.

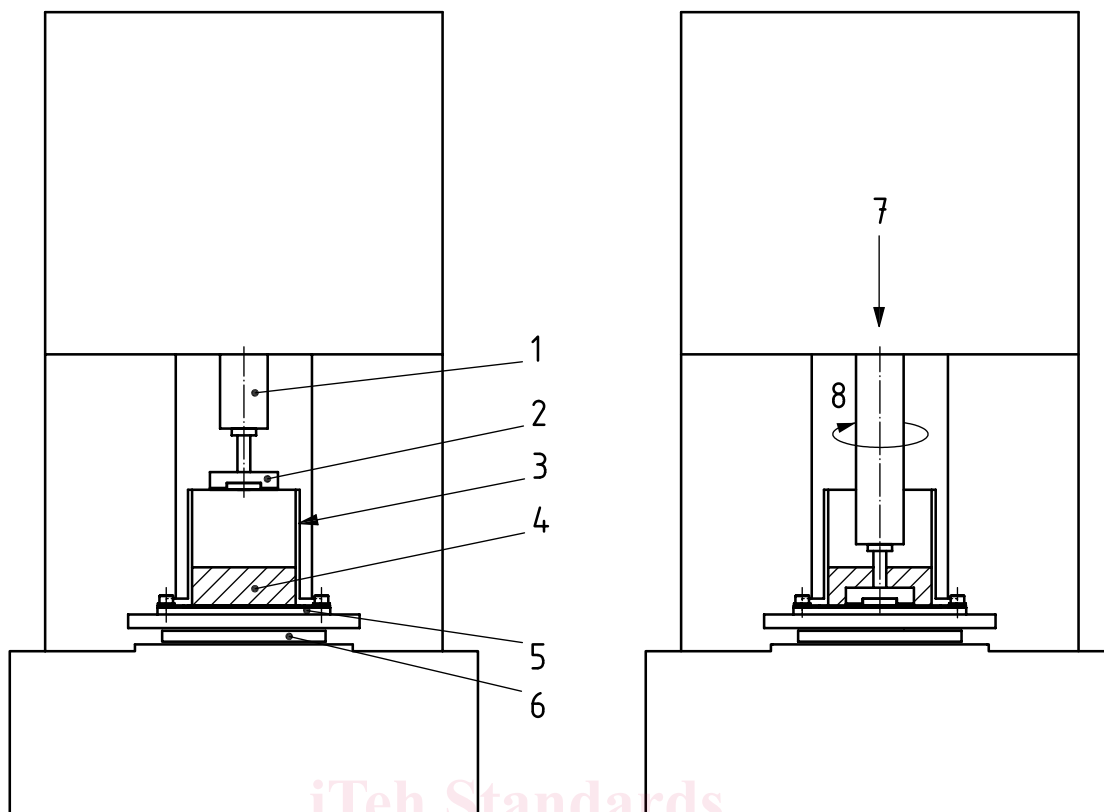

Key

- 1 spindle shaft
- 2 rotating disc
- 3 latex container
- 4 test portion of latex
- 5 flat-bottomed plate
- 6 load cell or scale
- 7 direction of loading
- 8 direction of rotation

(<https://standards.iteh.ai>)
 Document Preview

ISO 2006-2:2009

<https://standards.iteh.ai/catalog/standards/iso/a477da4f-cec6-49af-b9f1-ab58202d8c35/iso-2006-2-2009>

Figure 1 — Mechanical stability tester

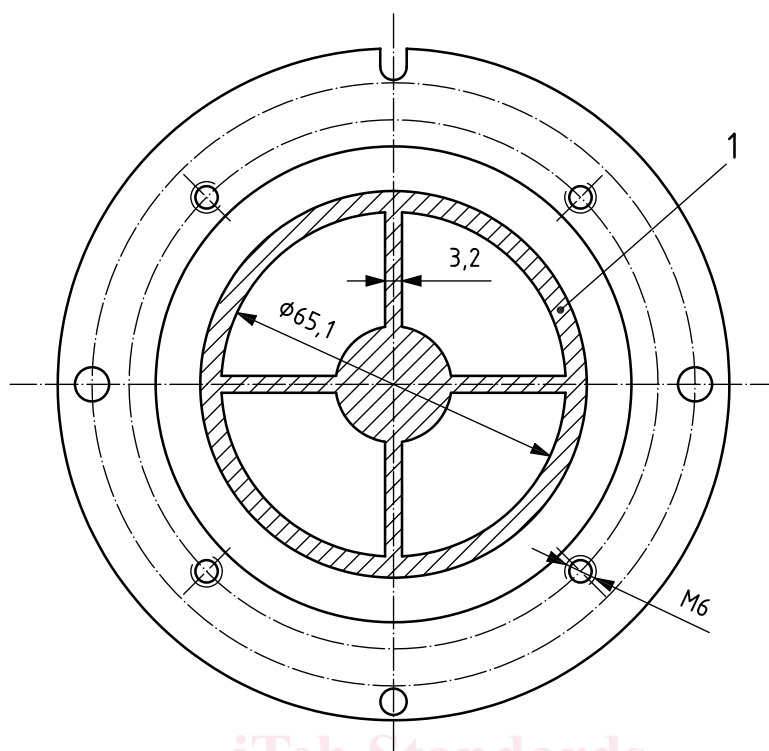

Key

- 1 groove, 1,6 mm in depth

iTeh Standards
(<https://standards.itih.ai>)
Document Preview

Figure 2 — Flat-bottomed plate

ISO 2006-2:2009

<https://standards.itih.ai/catalog/standards/iso/a477da4f-cec6-49af-b9f1-ab58202d8c35/iso-2006-2-2009>