**Rubber and plastics hoses and hose
assemblies — Determination of
permeability to gas**

*Tuyaux et flexibles en caoutchouc et en plastique — Détermination
de la perméabilité au gaz*

iTeh STANDARD PREVIEW
(standards.iteh.ai)

[ISO 4080:2009](https://standards.iteh.ai/catalog/standards/sist/02330449-4015-4dbd-8e45-4cb472b01e6c/iso-4080-2009)

[https://standards.iteh.ai/catalog/standards/sist/02330449-4015-4dbd-
8e45-4cb472b01e6c/iso-4080-2009](https://standards.iteh.ai/catalog/standards/sist/02330449-4015-4dbd-8e45-4cb472b01e6c/iso-4080-2009)



PDF disclaimer

This PDF file may contain embedded typefaces. In accordance with Adobe's licensing policy, this file may be printed or viewed but shall not be edited unless the typefaces which are embedded are licensed to and installed on the computer performing the editing. In downloading this file, parties accept therein the responsibility of not infringing Adobe's licensing policy. The ISO Central Secretariat accepts no liability in this area.

Adobe is a trademark of Adobe Systems Incorporated.

Details of the software products used to create this PDF file can be found in the General Info relative to the file; the PDF-creation parameters were optimized for printing. Every care has been taken to ensure that the file is suitable for use by ISO member bodies. In the unlikely event that a problem relating to it is found, please inform the Central Secretariat at the address given below.

iTeh STANDARD PREVIEW
(standards.iteh.ai)

ISO 4080:2009

<https://standards.iteh.ai/catalog/standards/sist/02330449-4015-4dbd-8e45-4cb472b01e6c/iso-4080-2009>



COPYRIGHT PROTECTED DOCUMENT

© ISO 2009

All rights reserved. Unless otherwise specified, no part of this publication may be reproduced or utilized in any form or by any means, electronic or mechanical, including photocopying and microfilm, without permission in writing from either ISO at the address below or ISO's member body in the country of the requester.

ISO copyright office
Case postale 56 • CH-1211 Geneva 20
Tel. + 41 22 749 01 11
Fax + 41 22 749 09 47
E-mail copyright@iso.org
Web www.iso.org

Published in Switzerland

Contents

Page

Foreword	iv
1 Scope	1
2 Normative references	1
3 Terms and definitions	1
4 Test pieces	2
5 Conditioning of test pieces	2
6 Test temperature	2
7 Test gas	2
8 Test pressure	2
9 Apparatus	2
10 Procedure	3
11 Expression of results	6
12 Test report	7

iTeh STANDARD PREVIEW
(standards.iteh.ai)

ISO 4080:2009

<https://standards.iteh.ai/catalog/standards/sist/02330449-4015-4dbd-8e45-4cb472b01e6c/iso-4080-2009>

Foreword

ISO (the International Organization for Standardization) is a worldwide federation of national standards bodies (ISO member bodies). The work of preparing International Standards is normally carried out through ISO technical committees. Each member body interested in a subject for which a technical committee has been established has the right to be represented on that committee. International organizations, governmental and non-governmental, in liaison with ISO, also take part in the work. ISO collaborates closely with the International Electrotechnical Commission (IEC) on all matters of electrotechnical standardization.

International Standards are drafted in accordance with the rules given in the ISO/IEC Directives, Part 2.

The main task of technical committees is to prepare International Standards. Draft International Standards adopted by the technical committees are circulated to the member bodies for voting. Publication as an International Standard requires approval by at least 75 % of the member bodies casting a vote.

Attention is drawn to the possibility that some of the elements of this document may be the subject of patent rights. ISO shall not be held responsible for identifying any or all such patent rights.

ISO 4080 was prepared by Technical Committee ISO/TC 45, *Rubber and rubber products*, Subcommittee SC 1, *Hoses (rubber and plastics)*.

This fourth edition cancels and replaces the third edition (ISO 4080:1991), which has been technically revised to clarify the test method procedures and to standardize the units in the expression of results clause for method 1 and method 2. It also incorporates the Technical Corrigendum ISO 4080:1991/Cor.2:1998.

[ISO 4080:2009](https://standards.iteh.ai/catalog/standards/sist/02330449-4015-4dbd-8e45-4cb472b01e6c/iso-4080-2009)

<https://standards.iteh.ai/catalog/standards/sist/02330449-4015-4dbd-8e45-4cb472b01e6c/iso-4080-2009>

Rubber and plastics hoses and hose assemblies — Determination of permeability to gas

WARNING — Persons using this International Standard should be familiar with normal laboratory practice. This standard does not purport to address all of the safety problems, if any, associated with its use. It is the responsibility of the user to establish appropriate safety and health practices and to ensure compliance with any national regulatory conditions.

1 Scope

This International Standard specifies three methods for the determination of the volume of gas diffusing through a rubber or plastics hose or length of tubing in a specified time.

Method 1: For determining the permeability of the complete hose or length of tubing, excluding end-fittings, to the test gas. The permeability is calculated with respect to the length of the hose or tubing.

Method 2: For determining the permeability at the hose/fitting interface. This method is used when determining the permeability characteristics of hoses with an unpricked cover, when the gas usually issues from the textile reinforcement at the cut ends. The permeability is calculated with respect to the length of the hose.

Method 3: For determining precisely the permeability of a hose or hose assembly to the test gas. The permeability is calculated with respect to the surface area of the hose lining.

The methods are applicable only to gases which are insoluble in water.

NOTE 1 Although the results are expressed in the same units for methods 1 and 2, the results obtained will not necessarily be comparable in the case of unpricked and pricked hoses intended for the same application as the test times specified are different and the permeability could therefore vary.

NOTE 2 Method 3 is the preferred method.

2 Normative references

The following referenced documents are indispensable for the application of this document. For dated references, only the edition cited applies. For undated references, the latest edition of the referenced document (including any amendments) applies.

ISO 8330, *Rubber and plastics hoses and hose assemblies — Vocabulary*

ISO 23529, *Rubber — General procedures for preparing and conditioning test pieces for physical test methods*

3 Terms and definitions

For the purposes of this document, the terms and definitions given in ISO 8330 apply.

4 Test pieces

4.1 Method 1

The test piece shall be a length of hose or tubing long enough to ensure that the length of the exposed hose or tubing under the gas-collecting trough is 1 m.

NOTE The cover of a hose test piece may be pricked.

4.2 Method 2

The test piece shall be a length of unpricked hose or tubing fitted with end couplings. It shall have a free length of 1 m between the couplings.

NOTE The type of coupling used and the method by which the couplings are fixed to the test piece can affect the results obtained using this method.

4.3 Method 3

The test piece shall be a length of unpricked hose fitted with end couplings. It shall have a free length of 0,5 m between the couplings.

5 Conditioning of test pieces

No test shall be carried out within 24 h of manufacture. Before testing, the test pieces shall be conditioned, in accordance with ISO 23529, for at least 3 h at the specified temperature and humidity.

6 Test temperature

<https://standards.iteh.ai/catalog/standards/sist/02330449-4015-4dbd-8e45-4cb472b01e6c/iso-4080-2009>

Unless otherwise specified in the product standard, the test shall be carried out at a temperature of $23\text{ °C} \pm 2\text{ °C}$.

7 Test gas

The test gas shall be as specified in the product standard.

8 Test pressure

Unless otherwise specified in the product standard, the test shall be carried out at a gas pressure of 1 MPa (10 bar).

9 Apparatus

NOTE Schematic layouts of the test arrangements for the three test methods are shown in Figures 1 to 3.

9.1 Water bath, capable of being maintained at a specified temperature and of sufficient length to accommodate the test piece.

9.2 Gas supply, provided with a suitable pressure gauge and emergency excess flow shutoff valves in case of test piece failure.

9.3 Gas-collecting apparatus, comprising measuring cylinders and in some instances additional apparatus appropriate to each of the three methods, as illustrated in Figures 1 to 3, respectively. The capacity and accuracy of the measuring cylinders shall be selected in accordance with the volume of gas that is expected to be collected.

9.4 Barometer, to record the barometric pressure during the test.

9.5 Two thermometers, to record the water temperature and air temperature at the gas-collection point.

10 Procedure

10.1 Method 1

Attach the appropriate feed and tail couplings to the test piece. Connect one end of the test piece to the specified gas supply (9.2) with a suitable connector. Purge the test assembly with gas for 30 s to expel the air before finally sealing the test assembly by blanking off the other end.

Adjust the temperature of the water bath (9.1) to the specified value.

Immerse the test assembly in the water bath. Apply the gas pressure and maintain this pressure for 72 h prior to collecting any gas.

Arrange the gas-collecting apparatus (9.3) above the test piece as shown in Figure 1 and measure and record the time taken to collect 3,0 cm³ of gas. If the volume of gas collected after 24 h is less than 3,0 cm³ but more than 1 cm³, then this can be taken as the reading. Repeat the measurement a further two times. Alternatively, measure the volume of gas collected in a 24 h period.

If the permeability is required to be determined at different pressures, test at the lowest pressure first and then at increasing pressure levels.

<https://standards.iteh.ai/catalog/standards/sist/02330449-4015-4dbd-8e45-4cb472b01e6c/iso-4080-2009>

10.2 Method 2

Attach the appropriate feed and tail couplings to the test piece. Connect the feed end to the specified gas supply (9.2) and purge the assembly with gas for 30 s to expel the air before finally sealing the test assembly by blanking off the tail coupling.

Maintaining the test assembly at the specified test temperature, apply the gas pressure to the assembly and maintain this pressure for 24 h. Following this period, immerse the test assembly and its end connections in the water bath (9.1) at the specified temperature (see Figure 2).

Position the two measuring cylinders and the collection funnels as shown in Figure 2 so as to collect and measure any gas which escapes from the two ends of the test piece for a period of 1 h. Record the total volume of gas collected as the first reading. Then remove the assembly from the water bath and hold it at the specified temperature and gas pressure for another 24 h.

After 24 h, re-immerses the assembly in the water bath and collect and measure the gas as previously.

Carry out this process a total of six times.

If the permeability is required to be determined at different pressures, test at the lowest pressure first and then at increasing pressure levels.

NOTE It is important to remove the assembly from the water bath after each 1 h period and not leave it immersed, since the exposed textile reinforcement could swell and lead to unrepresentative results.

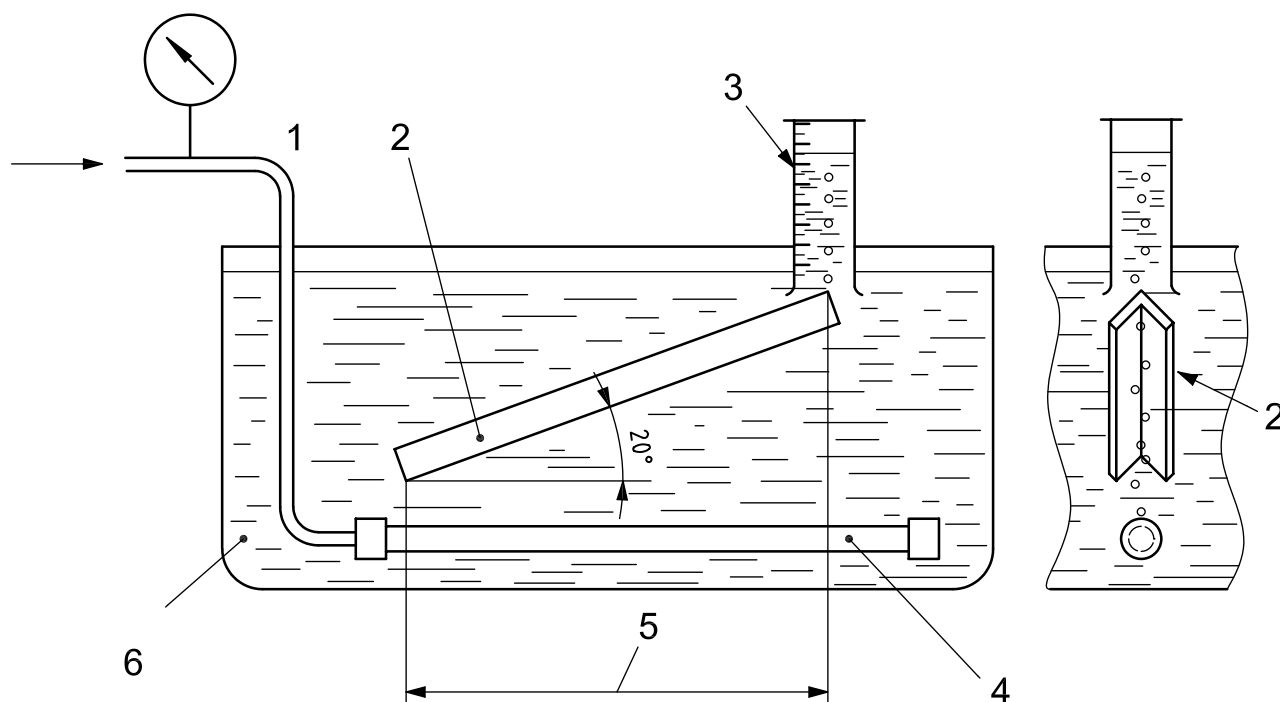

Key

- 1 gas supply
- 2 collecting trough
- 3 measuring cylinder
- 4 test piece
- 5 1 m of free hose
- 6 water bath

iTeh STANDARD PREVIEW
(standards.iteh.ai)

[ISO 4080:2009](https://standards.iteh.ai/catalog/standards/sist/02330449-4015-4dbd-8e45-4cb472b01e6c/iso-4080-2009)

<https://standards.iteh.ai/catalog/standards/sist/02330449-4015-4dbd-8e45-4cb472b01e6c/iso-4080-2009>

Figure 1 — Schematic apparatus for method 1

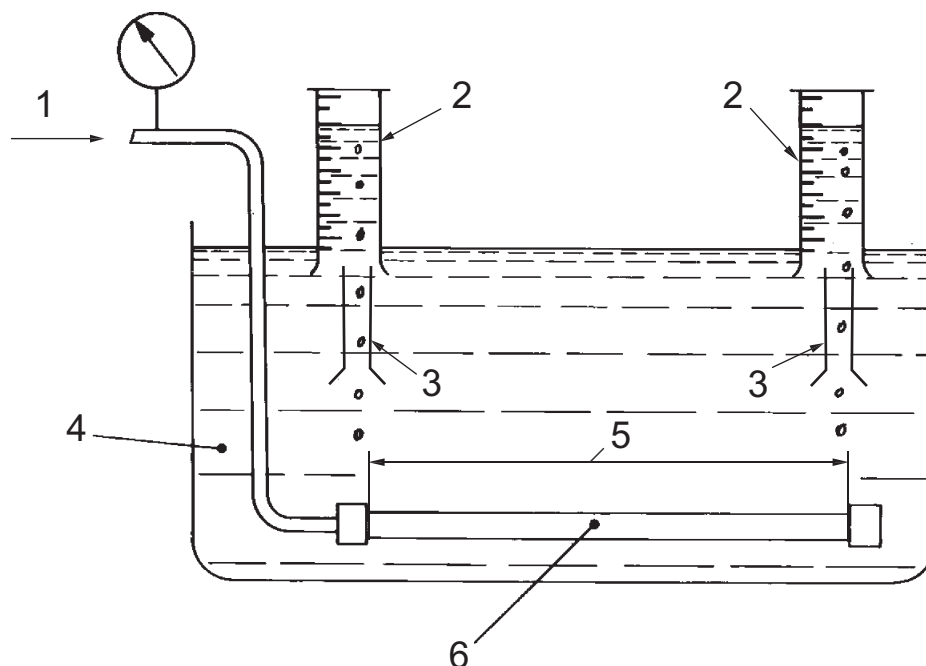
**Key**

- 1 gas supply
- 2 measuring cylinders
- 3 collecting funnels
- 4 water bath
- 5 1 m of hose
- 6 test piece

iTeh STANDARD PREVIEW
(standards.iteh.ai)

[ISO 4080:2009](https://standards.iteh.ai/catalog/standards/sist/02330449-4015-4dbd-8e45-4cb472b01e6c/iso-4080-2009)

<https://standards.iteh.ai/catalog/standards/sist/02330449-4015-4dbd-8e45-4cb472b01e6c/iso-4080-2009>

Figure 2 — Schematic apparatus for method 2

10.3 Method 3

Partially seal one end of the test piece and connect the other end to the specified gas supply (9.2). Purge the test assembly with gas for 30 s to expel the air before finally sealing the test assembly. Adjust the temperature of the water bath (9.1) to the specified temperature.

Insert the test assembly into the glass tube and immerse in the water bath so that they are inclined at approximately 20° to the horizontal (see Figure 3). Apply the gas pressure and maintain it for 14 days. At the end of this period, while still maintaining the specified pressure, collect the gas for 6 h or record the time to collect between 450 cm³ and 500 cm³ of gas. Repeat this procedure every 24 h until two successive gas volumes are within 5 % of each other. Use the average of these two successive readings for the calculation of the permeability.

If the permeability is required to be determined at different pressures, test at the lowest pressure first and then at increasing pressure levels.