



Designation: G86 – 98a (Reapproved 2005)

Standard Test Method for Determining Ignition Sensitivity of Materials to Mechanical Impact in Ambient Liquid Oxygen and Pressurized Liquid and Gaseous Oxygen Environments¹

This standard is issued under the fixed designation G86; the number immediately following the designation indicates the year of original adoption or, in the case of revision, the year of last revision. A number in parentheses indicates the year of last reapproval. A superscript epsilon (ϵ) indicates an editorial change since the last revision or reapproval.

1. Scope

1.1 This test method² describes test equipment and techniques to determine the impact sensitivity of materials in oxygen under two different conditions: (1) in ambient pressure liquid oxygen (LOX) or (2) under pressure-controlled conditions in LOX or gaseous oxygen (GOX). It is applicable to materials for use in LOX or GOX systems at pressures from ambient to 68.9 MPa (0 to 10 000 psig). The test method described herein addresses testing with pure oxygen environments; however, other oxygen-enriched fluids may be substituted throughout this document.

1.2 This test method provides a means for ranking nonmetallic materials as defined in Guide G63 for use in liquid and gaseous oxygen systems and may not be directly applicable to the determination of the sensitivity of the materials in an end-use configuration. This test method may be used to provide batch-to batch acceptance data. This test method may provide a means for evaluating metallic materials in oxygen-enriched atmospheres also; however, Guide G94 should be consulted for preferred testing methods.

1.3 Values stated in SI units are to be regarded as the standard. The values given in parentheses are for information only.

1.4 *This standard does not purport to address all of the safety concerns, if any, associated with its use. It is the responsibility of the user of this standard to establish appropriate safety and health practices and determine the applicability of regulatory limitations prior to use.* See also Section 9.

¹ This test method is under the jurisdiction of ASTM Committee G04 on Compatibility and Sensitivity of Materials in Oxygen Enriched Atmospheres and is the direct responsibility of G04.01 on Test Methods.

Current edition approved Sept. 1, 2005. Published December 2005. Originally approved in 1984. Last previous edition approved in 1998 as G86 - 98a. DOI: 10.1520/G0086-98AR05.

² NASA Handbook 8060.1B, *Pressurized Liquid and Gaseous Oxygen Mechanical Impact Test*, Sept. 1981, pp. 4-72.

2. Referenced Documents

2.1 ASTM Standards:³

- D1193 Specification for Reagent Water
- D4080 Specification for Trichloroethylene, Technical and Vapor-Degreasing Grade
- G63 Guide for Evaluating Nonmetallic Materials for Oxygen Service
- G88 Guide for Designing Systems for Oxygen Service
- G93 Practice for Cleaning Methods and Cleanliness Levels for Material and Equipment Used in Oxygen-Enriched Environments
- G94 Guide for Evaluating Metals for Oxygen Service

2.2 Military Document:⁴

- MIL-D-16791 Detergent, General Purpose (Liquid, Non-ionic), Type One

2.3 American Chemical Society:⁵

- Trichloroethylene, Reagent Grade

2.4 Compressed Gas Association:⁶

- G-4 Oxygen

G-4.1 Cleaning Equipment for Oxygen Service

- G-4.3 Oxygen, Gaseous, Type I B

- G-4.3 Oxygen, Liquid, Type II B

- G-10.1 Nitrogen, Gaseous, Type I B

- G-10.1 Nitrogen, Liquid, Type II B

2.5 NASA Standard:⁷

- NSS 1740.15 Safety Standard for Oxygen and Oxygen Systems

³ For referenced ASTM standards, visit the ASTM website, www.astm.org, or contact ASTM Customer Service at service@astm.org. For *Annual Book of ASTM Standards* volume information, refer to the standard's Document Summary page on the ASTM website.

⁴ Available from Standardization Documents Order Desk, DODSSP, Bldg. 4, Section D, 700 Robbins Ave., Philadelphia, PA 19111-5098, <http://dodssp.daps.dla.mil>.

⁵ Available from American Chemical Society (ACS), 1155 Sixteenth Street, NW Washington, DC 20036, <http://www.acs.org>.

⁶ Available from Compressed Gas Association (CGA), 4221 Walney Rd., 5th Floor, Chantilly, VA 20151-2923, <http://www.cganet.com>.

⁷ Available from National Aeronautics and Space Administration (NASA), NASA Headquarters, Suite 1M32, Washington, DC 20546.

2.6 ASTM Adjuncts:
ABMA-Type Impact Tester and Anvil⁸

3. Terminology

3.1 Definitions of Terms Specific to This Standard:

3.1.1 GOX, *n*—gaseous oxygen.

3.1.2 LOX, *n*—liquid oxygen.

3.1.3 *mechanical impact, n*—a blow delivered by a plummet that has been dropped from a preestablished height onto a striker pin in contact with a sample.

3.1.4 *reaction, n*—a chemical change or transformation in the sample initiated by a mechanical impact.

3.1.4.1 *Discussion*—A reaction from ambient pressure, LOX mechanical impact may be determined by an audible report, an electronically or visually detected flash, obvious charring of the sample, cup, or striker pin.

3.1.4.2 *Discussion*—Reactions in pressurized LOX or GOX are typically indicated by an abrupt increase in test sample temperature, chamber pressure, and light levels and may be supplemented by obvious changes in odor, color, or material appearance as a result of thermal decompositions observed during examination after the test.

3.1.5 *pressure threshold, n*—the highest pressure at a given impact energy level for which the passing criteria have been met.

3.1.6 *energy threshold, n*—the highest impact energy level at a given pressure for which the passing criteria have been met.

4. Summary of Test Method

4.1 The mechanical impact test system is designed to expose material samples to mechanical impact in the presence of liquid or gaseous oxygen at pressures from ambient to 68.9 MPa (0 to 10 000 psig). The basic drop tower configuration consists of: an electromagnet, a plummet, plummet guide tracks, plummet hold/release mechanism, base plate, anvil plate, a specimen cup holder, sample cup, and striker pin (see Fig. 1). For tests conducted under pressure-controlled conditions, the anvil plate and specimen cup holder are replaced with a test chamber equipped with a striker pin or striker pin counterloader (see Fig. 2), test chamber purge, pressurization and vent systems (see Fig. 3), and a plummet catcher (see Fig. 4). The general procedure is to prepare the test sample and record significant pretest data.

4.2 *Ambient LOX Impact Test*—The test conditions (pressure and temperature) are the ambient pressure of the test facility and the boiling point of LOX at that pressure. Each sample is placed into a specimen cup (see Fig. 5), precooled in a sample freezing box (Fig. 6), covered with LOX, and placed in the cup holder seater in the anvil assembly of the impact tester. The plummet is dropped from a selected height onto the striker pin, which transmits the energy to the test sample.

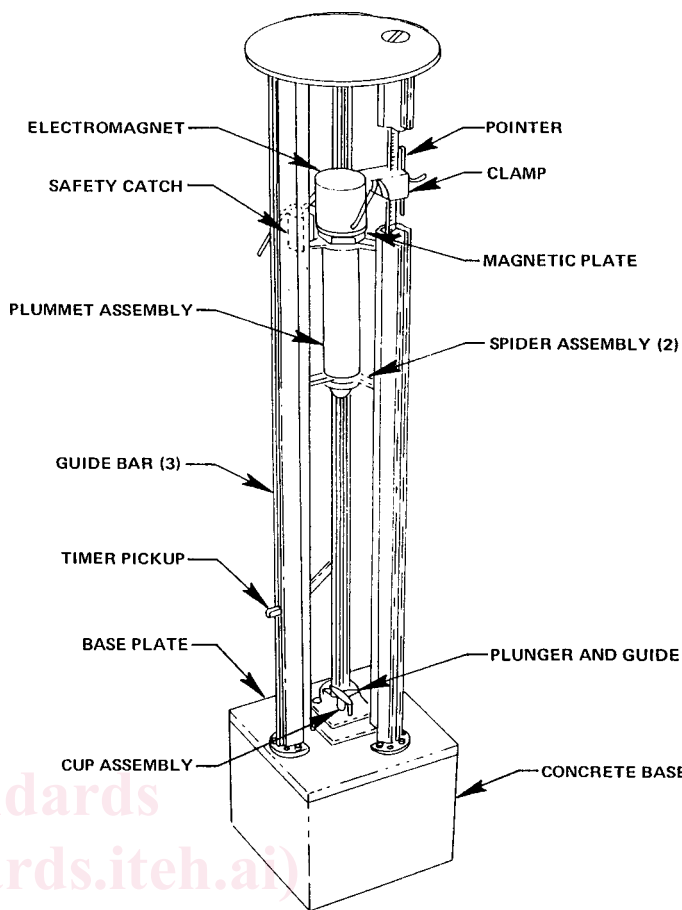

FIG. 1 Oxygen Impact Test Frame

Observation for any reaction is made and noted. Drop tests are continued using a fresh sample, sample cup, and striker pin for each drop until the threshold level is determined or the test series is completed.

4.3 For materials tested in pressurized LOX or GOX, each sample is placed in the test chamber. The test chamber is filled with liquid or gaseous oxygen, pressurized to the required test pressure, and the striker pin or striker pin counterloader is pressed down against the top of the test sample. The plummet is dropped from a selected height onto the striker pin or striker pin counterloader. Instrumentation devices that monitor the test chamber interior for pressure, temperature, and light emission provide evidence of test sample reaction. The sample is removed from the chamber, and the sample is inspected for other evidence of reaction such as odor or charring. Drop tests are continued using a fresh sample, sample holder, and striker pin or striker pin counterloader for each drop, until the threshold level is determined or the test series is completed. Additional modifications to the above procedure are required when testing is performed at temperatures above ambient.

4.4 This test method may be used to determine the impact sensitivity of a material, batch-to-batch acceptance, or to satisfy other prescribed pass-fail criteria.

⁸ Detailed drawings from the ABMA-Type Impact Tester and Anvil Region Assembly are available at a nominal fee from ASTM International, 100 Barr Harbor Dr., Philadelphia, PA 19428. Request Adjunct ADJD2512.

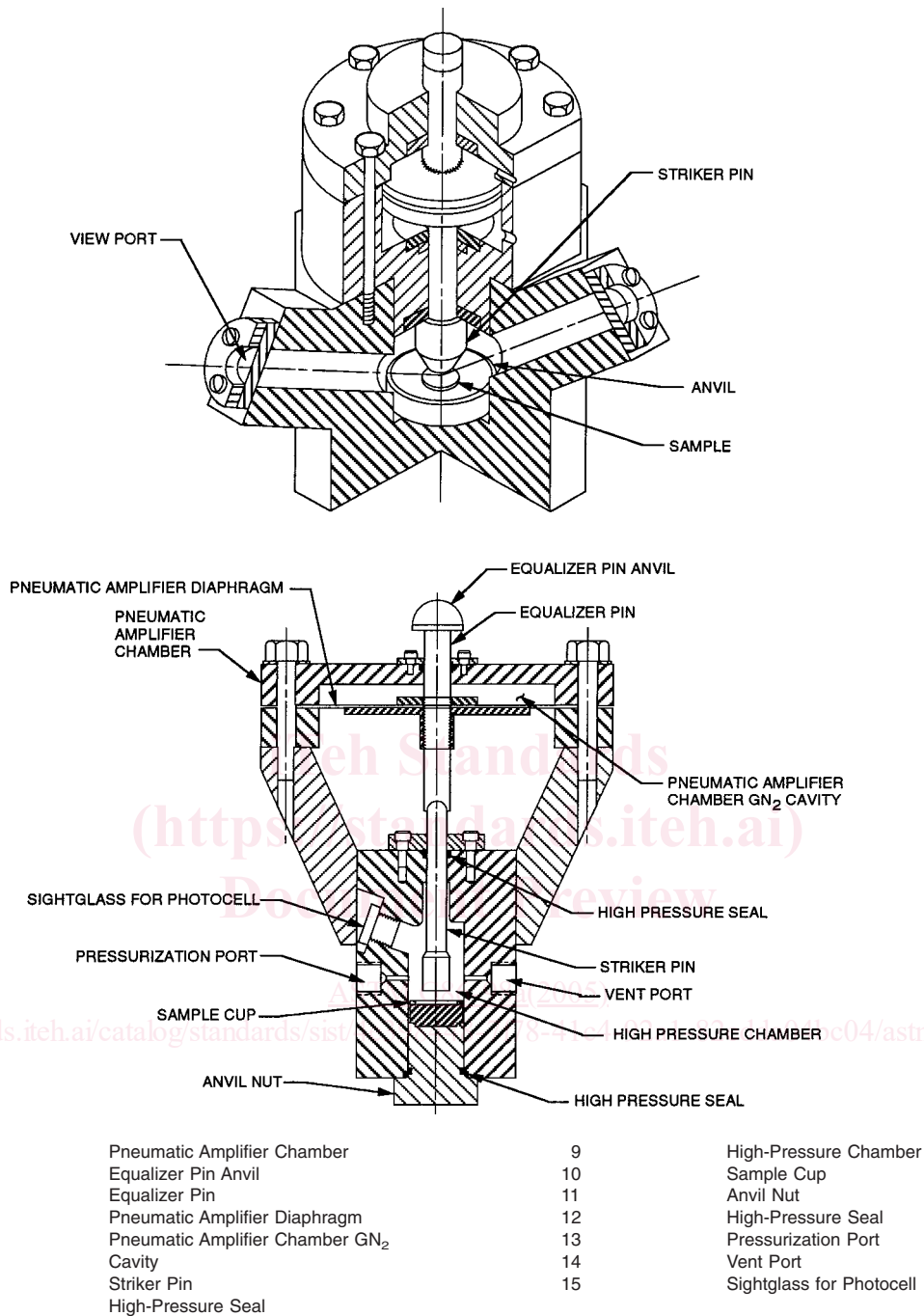

FIG. 2 Two Types of High-Pressure Test Chambers

5. Significance and Use

5.1 This test method evaluates the relative sensitivity of materials to mechanical impact in ambient pressure liquid oxygen, pressurized liquid oxygen, and pressurized gaseous oxygen.

5.2 Any change or variation in test sample configuration, thickness, preparation, or cleanliness may cause a significant change in impact sensitivity/reaction threshold.

5.3 Suggested criteria for discontinuing the tests are: (1) occurrence of two reactions in a maximum of 60 samples or less tested at the maximum energy level of 98 J (72 ft•lbf) or one reaction in a maximum of 20 samples tested at any other energy level for a material that fails; (2) no reactions for 20 samples tested at the 98-J (72-ft•lbf) energy level; or (3) a maximum of one reaction in 60 samples tested at the maximum energy level.

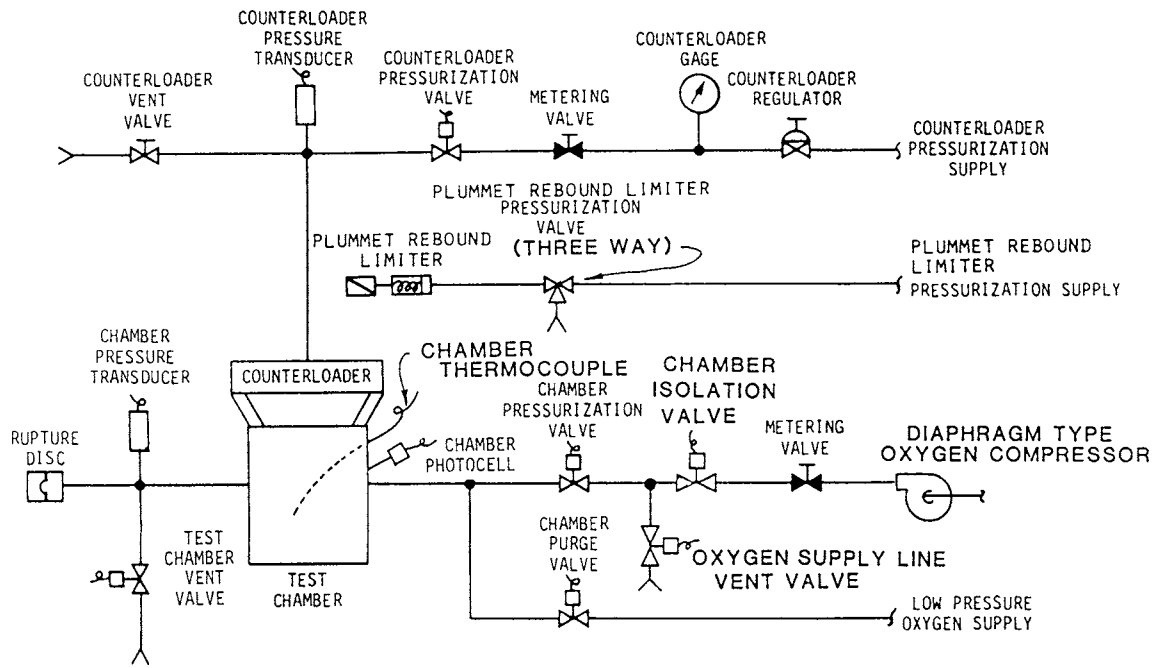

FIG. 3 Typical Pressurization Piping system for a LOX/GOX Pressurized Test System

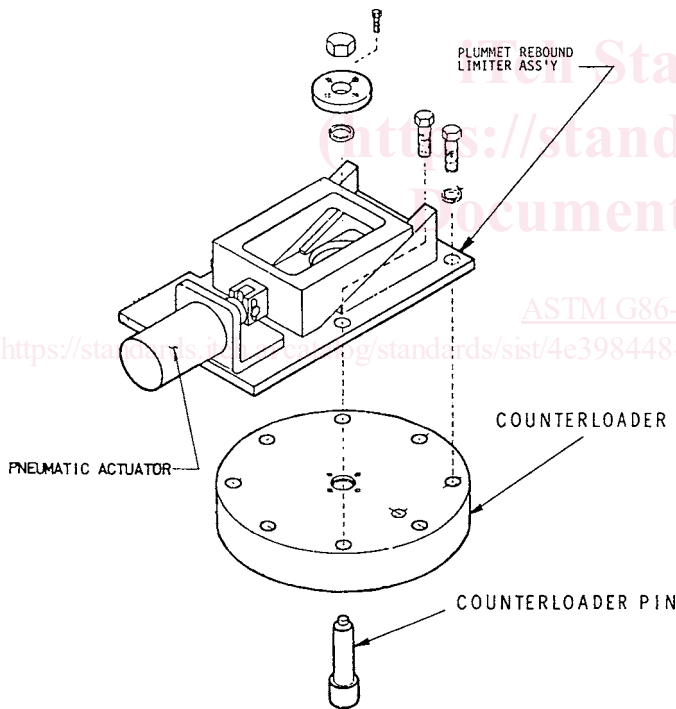
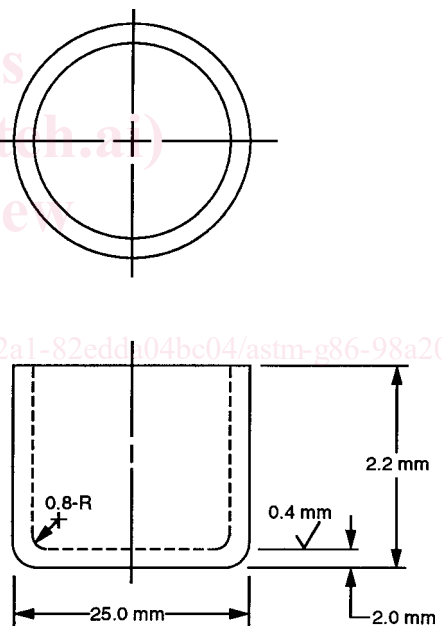

FIG. 4 Typical Plummet Rebound Limiter Assembly



- NOTE 1—Break sharp edges 0.4 mm.
- NOTE 2—The cup is formed by deep drawing.
- NOTE 3—The thickness and parallelness of the cup bottom shall be controlled to 2.0 mm by coining.
- NOTE 4—Material: any 3000 or 5000 series aluminum alloy.

FIG. 5 LOX Impact Tester One-Piece Sample Cup

6. Criteria for Acceptance for Ambient LOX and Pressurized LOX and GOX Mechanical Impact Test

6.1 To meet the requirements for acceptability, the material shall show no reaction when being subjected to 20 successive impact tests tested at 98 J (72 ft•lbf) using the equipment described in Section 10.

6.2 The test may be discontinued and the materials considered to have failed if there is one reaction in 20 drops at any energy level less than 98 J (72 ft•lbf).

6.3 A material is acceptable after 60 successive impact tests with not more than one reaction at 98 J (72 ft•lbf). The test may be terminated and the material considered to have failed if there are two reactions in 60 tests or less at 98 J (72 ft•lbf).

6.4 The material shall show none of the following reactions during any of the tests.

6.4.1 Audible explosion.

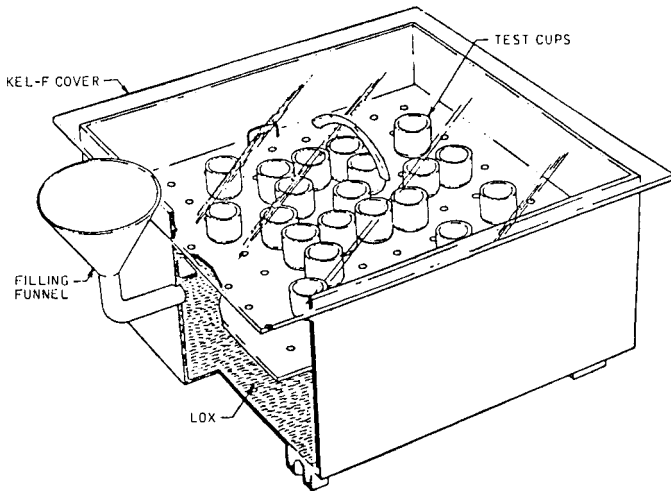

FIG. 6 Typical Sample Freezing Box

- 6.4.2 Flash (electronically or visually detected).
- 6.4.3 Evidence of burning (obvious charring, see Note 1).
- 6.4.4 Major discoloration (as a result of ignition only rather than other phenomena).
- 6.4.5 A temperature or pressure spike in elevated temperature tests.

NOTE 1—A burnt odor alone is not considered sufficient proof that a reaction has occurred. If a reaction occurs (including those during bounce of plummet), it shall be reported as evidence of sensitivity. Inclusion of bounce reactions applies to ambient LOX mechanical impact tests only.

6.5 All materials that fail 6.1 criteria and remain candidates for use must be subjected to LOX or GOX mechanical impact energy threshold determinations in the thickness of use.

6.6 The material to be tested must be traceable back to the original manufacturer and to a specific batch or lot numbers, or both.

6.7 The thickness of the sample shall be the worst-case thickness. While the worst-case thickness has been found to vary from material to material, the general trend has been that thinner samples of materials are generally more reactive.

6.8 For the ambient LOX impact test, test conditions (pressure and temperature) are the ambient pressure of the test facility and the boiling point of LOX at that pressure. For the pressurized test, test conditions (pressure and temperature) shall be determined for each test according to the requirements specified by the requester.

6.9 Preparation of the samples for testing involve the following tasks.

- 6.9.1 Receiving the visually inspecting the material.
- 6.9.2 Preparing the sample to the specified dimensions.
- 6.9.3 Cleaning the samples.
- 6.9.4 Inspecting the samples.

7. Sample Preparation

7.1 The material to be tested must be traceable back to the original manufacturer and to specific batch or lot numbers, or to both. When received, the test material must be accompanied by proper identification, for example, product data sheets, batch or lot numbers identifying the sample, material manufacturer, and appropriate material safety data sheets. The

material must be inspected to ensure that it is at the worst-case use thickness and any flaws shall be noted. Preparation of samples for testing involve the following tasks: (1) receiving and visually inspecting the material, (2) preparing samples to the proper dimensions, (3) cleaning the samples, and (4) inspecting the samples.

7.1.1 Sufficient material shall be available to permit preparation and testing of 140 separate 17.5-mm (¹¹/₁₆-in.) diameter disk samples. Sheet materials up to 6.3-mm (¹/₄-in.) in thickness shall be tested as 17.5 mm (¹¹/₁₆-in.) diameter disks in the thickness intended for use (see Table 1).

7.1.2 Materials normally used in thicknesses greater than 6.35 mm (¹/₄ in.) shall be sized and tested as 17.5-mm diameter disks of 6.35- ± 0.13-mm (0.250- ± 0.006-in.) thickness. Failure of samples to meet the requirements of this test method shall be cause for the rejection of the material. Greases, fluids, and other materials, whose thicknesses are directed by conditions of use, shall be tested as 1.27- ± 0.13-mm (0.050- ± 0.005-in.) layers in special test cups. Materials not readily available in sheet form shall be tested in the available configuration. Specimens shall be free of ragged edges, fins, or other irregularities.

7.2 *Liquid Samples*—Prepare a homogeneous sample. A microburette may be used to transfer the sample into special sample cups 1.27 ± 0.13 mm (0.050 ± 0.005 in.) deep (see Fig. 7). For highly viscous materials, a microsyringe may be used. Determine the volume of the sample required to obtain a sample thickness of 1.27 ± 0.13 mm (0.050 ± 0.005 in.) in the sample cup. This determination is required due to variations in such physical properties as density, surface tension, and volatility from liquid to liquid. A micrometre depth gauge with leveling blocks is suggested for measurement. The work table must be level. Test material should be loaded into the sample cup just before loading the cup into the test chamber (or freezing box, if testing in liquid oxygen).

7.3 *Leak Check Compounds, Dye, Dye Penetrant, and Emulsifier, Method 1*—Clean, unsealed, sulfuric acid-anodized 6061-T6 aluminum alloy disks (or any other substrate specified by the manufacturer or requester), 17.5 mm (¹¹/₁₆ in.) in diameter by 1.60 mm (0.063 in.) thick are used as a carrier. Clean the disks before use (see 11.2.2.1). To ascertain the effectiveness of the cleaning procedure, test a minimum of 20 blank disks. After cleaning and blank testing, dip new anodized disks in the test materials for 15 min and drain for 15 min with the disks oriented vertically. Cure the sample as specified, then store the prepared disks in a clean container until required for testing.

TABLE 1 Recommended Minimum Quantities of Material Required for Testing

Material Form ^A	Minimum Quantities
Sheets	2000-cm ² (319-in. ²) total area by 3.5-mm (¹ / ₈ -in.) maximum thickness
Coatings, inks, and adhesives	120 cm ² (4 fluid oz.)
Foams	2000-cm ² (310-in. ²) total area by 3.5-mm (¹ / ₈ -in.) maximum thickness
Insulated wires	50 cm (20 in.) in length

^A Actual test configurations and material quantities for material forms other than those listed (for example, O-rings and seals) must be established and approved by the responsible procurement or user materials organization.

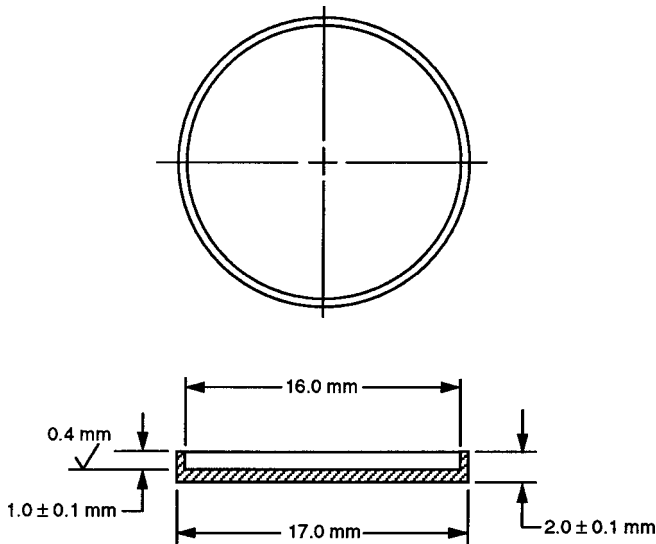

NOTE 1—Material: any 3000 or 5000 series aluminum alloy.
NOTE 2—Break all sharp edges 0.19 mm.

FIG. 7 LOX Impact Tester Special Insert

7.3.1 Reactions involving materials prepared on aluminum disks have the potential for being extremely severe as a result of ignition of the aluminum disk, which may be initiated by a reaction of the test material. For this reason, Method 2 (7.4) is provided as an alternative procedure for preparing this type of material. In conjunction with Method 2, the user or test agency may elect to use sample cups of the same material on which the dye, dye penetrant, or emulsifier is used in actual service.

7.4 Preparation of Dye, Dye Penetrant, Leak Check Compounds, and Emulsifier, Method 2—Clean sample cups 1.27 ± 0.13 mm (0.050 ± 0.005 in.) deep or Type 316 stainless steel disks (see Fig. 8) of the same dimensions specified for the aluminum disks in 10.1.1.5 are used as a carrier (unless other base metal is specified). Before use, the sample cups or disks

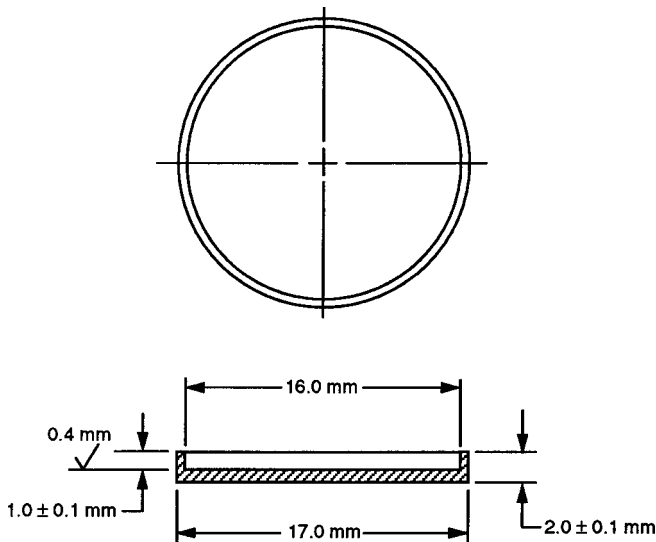

NOTE 1—Material: Type 347 stainless steel.
NOTE 2—Break all sharp edges 0.19 mm.

FIG. 8 One-Piece Insert Cup

are cleaned as directed in 11.2.5, and the effectiveness of the cleaning procedure is verified in 11.4. The test material is applied to the inside bottom of the sample cup or to one side of the stainless steel disks in a thickness and a manner simulating actual use, then dried or cured as it would be in actual use. (Alternative method: dip and drain as directed in 7.8.) The resultant thickness is measured and recorded on the test data sheet. Store the prepared test samples in a clean container until required for testing.

7.5 Preparation of Greases and Semisolids—Press a sufficient amount of sample material (a slight excess) into a special sample cup 1.27 ± 0.13 mm (0.050 ± 0.005 in.) deep (see Fig. 7) with a cleaned, stainless steel spatula to form a uniform sample free of bubbles and void areas. Scrape the excess sample level to the rim of the sample cup until a smooth surface is obtained. It is necessary to fill the sample cup uniformly. Store the prepared sample cups in a clean container until required for testing.

7.6 Preparation of Solids—Cut and prepare samples of solid material to a diameter of 17.5 mm ($11/16$ in.). Sheet material not available in 1.52 ± 0.13 -mm (0.060 ± 0.005 -in.) thickness is tested in the thickness intended for use when that thickness is not more than 6.35 mm (0.250 in.). Materials normally used in a thickness greater than 6.35 mm (0.250 in.) are cut to provide disks of 1.52 ± 0.13 -mm (0.060 ± 0.005 -in.) thickness. The samples should be cleaned by the same method that will be used in the material application. Alternatively, the samples may be cleaned by rinsing with an oxygen-compatible solvent that is compatible with the test material, then detergent rinsed, distilled-water rinsed, and dried using filtered (25- μ m absolute or smaller filter rating) dry air or inert gas, unless otherwise specified. If the sample material cannot be wetted with any cleaning solution without altering the test sample, the samples shall be blown clean using filtered (25- μ m absolute or smaller filter rating) dry air or inert gas.

7.7 Preparation of Solder (Solid or Flux-Core Type)—Prepare solder samples as follows: melt the solder (solid or flux-core type) at a temperature not higher than 25°C above the melting point of the solder in a mold to form an ingot. Roll the ingot to form a flat sheet 0.51 ± 0.13 (0.020 ± 0.005 in.) thick. Punch disks of 17.5-mm ($11/16$ -in.) diameter from the sheet. Clean the disks by detergent washing, water rinsing, drying, and vapor degreasing in an appropriate solvent. Store the prepared samples in a clean container until required for testing.

7.8 Preparation of Coatings, Paints, Adhesives, and Potting Compounds—Materials of this type are prepared as follows.

7.8.1 Coating materials, such as paints, dry film lubricants, and conformal coatings, shall be applied to 17.5-mm ($11/16$ -in.) diameter by 1.6-mm (0.063-in.) thick 316 or 347 stainless steel disks in the same manner and to the same thickness intended for use. After the samples have dried, they shall be placed in the regular sample cups for ambient pressure testing and used as prepared in the pressurized impact tester.

7.8.2 Elastomeric coatings and adhesives shall be applied as a coating to 316 or 347 stainless steel disks using Method 1 or Method 2 described below and cured according to applicable instructions.