**Road vehicles — Securing of cargo
in delivery vans — Requirements and test
methods**

*Véhicules routiers — Arrimage des charges à bord des camionnettes
de livraison — Exigences et méthodes d'essai*

iTeh STANDARD PREVIEW
(standards.iteh.ai)

[ISO 27956:2009](https://standards.iteh.ai/catalog/standards/sist/662ec008-f91d-48e9-b8b9-6d70f767742a/iso-27956-2009)

<https://standards.iteh.ai/catalog/standards/sist/662ec008-f91d-48e9-b8b9-6d70f767742a/iso-27956-2009>



PDF disclaimer

This PDF file may contain embedded typefaces. In accordance with Adobe's licensing policy, this file may be printed or viewed but shall not be edited unless the typefaces which are embedded are licensed to and installed on the computer performing the editing. In downloading this file, parties accept therein the responsibility of not infringing Adobe's licensing policy. The ISO Central Secretariat accepts no liability in this area.

Adobe is a trademark of Adobe Systems Incorporated.

Details of the software products used to create this PDF file can be found in the General Info relative to the file; the PDF-creation parameters were optimized for printing. Every care has been taken to ensure that the file is suitable for use by ISO member bodies. In the unlikely event that a problem relating to it is found, please inform the Central Secretariat at the address given below.

iTeh STANDARD PREVIEW
(standards.iteh.ai)

ISO 27956:2009

<https://standards.iteh.ai/catalog/standards/sist/662ec008-f91d-48e9-b8b9-6d70f767742a/iso-27956-2009>



COPYRIGHT PROTECTED DOCUMENT

© ISO 2009

All rights reserved. Unless otherwise specified, no part of this publication may be reproduced or utilized in any form or by any means, electronic or mechanical, including photocopying and microfilm, without permission in writing from either ISO at the address below or ISO's member body in the country of the requester.

ISO copyright office
Case postale 56 • CH-1211 Geneva 20
Tel. + 41 22 749 01 11
Fax + 41 22 749 09 47
E-mail copyright@iso.org
Web www.iso.org

Published in Switzerland

Contents

Page

Foreword.....	iv
1 Scope	1
2 Terms and definitions	1
3 Requirements	2
3.1 General requirements	2
3.2 Partitioning system	2
3.3 Lashing points	4
4 Test methods	8
4.1 Static load tests of the partitioning system	8
4.2 Testing of the strength of the lashing point	10
Bibliography	13

iTeh STANDARD PREVIEW
(standards.iteh.ai)

[ISO 27956:2009](https://standards.iteh.ai/catalog/standards/sist/662ec008-f91d-48e9-b8b9-6d70f767742a/iso-27956-2009)

<https://standards.iteh.ai/catalog/standards/sist/662ec008-f91d-48e9-b8b9-6d70f767742a/iso-27956-2009>

Foreword

ISO (the International Organization for Standardization) is a worldwide federation of national standards bodies (ISO member bodies). The work of preparing International Standards is normally carried out through ISO technical committees. Each member body interested in a subject for which a technical committee has been established has the right to be represented on that committee. International organizations, governmental and non-governmental, in liaison with ISO, also take part in the work. ISO collaborates closely with the International Electrotechnical Commission (IEC) on all matters of electrotechnical standardization.

International Standards are drafted in accordance with the rules given in the ISO/IEC Directives, Part 2.

The main task of technical committees is to prepare International Standards. Draft International Standards adopted by the technical committees are circulated to the member bodies for voting. Publication as an International Standard requires approval by at least 75 % of the member bodies casting a vote.

Attention is drawn to the possibility that some of the elements of this document may be the subject of patent rights. ISO shall not be held responsible for identifying any or all such patent rights.

ISO 27956 was prepared by Technical Committee ISO/TC 22, *Road vehicles*, Subcommittee SC 12, *Passive safety crash protection systems*.

iTeh STANDARD PREVIEW (standards.iteh.ai)

[ISO 27956:2009](https://standards.iteh.ai/catalog/standards/sist/662ec008-f91d-48e9-b8b9-6d70f767742a/iso-27956-2009)

<https://standards.iteh.ai/catalog/standards/sist/662ec008-f91d-48e9-b8b9-6d70f767742a/iso-27956-2009>

Road vehicles — Securing of cargo in delivery vans — Requirements and test methods

1 Scope

This International Standard applies to vehicle-relevant equipment for the securing of cargo in delivery vans with a gross vehicle mass up to 7,5 t. This International Standard specifies minimum requirements and test methods for securing cargo in a reliable and roadworthy way, in order to protect occupants against injuries caused by shifting cargo.

This International Standard deals with N1 vehicles and N2 vehicles up to 7,5 t in accordance with ECE classification¹⁾. For vehicles primarily designed for the transportation of cargo and derived from a passenger vehicle (M1), only the requirements concerning the partitioning system of this International Standard apply.

NOTE Extreme loads (e.g. vehicle impacts) that can occur during an accident are outside the scope of this International Standard.

iTeh STANDARD PREVIEW

2 Terms and definitions (standards.iteh.ai)

For the purposes of this document, the following terms and definitions apply.

2.1 delivery van

vehicle for the transport of cargo, of which the occupant compartment and loading space form one unit

2.2 lashing point

attachment part on the vehicle or an integrated device, to which **lashing devices** (2.3) can be connected in a form-fit manner and designed to transfer the lashing forces to the vehicle structure

NOTE An integrated device can be, for example, a ring, a loop, a tie-down, a hook, an eye, a lug, a hook-in edge, a thread connection, or rails.

2.3 lashing device

device that is designed to be attached to the **lashing points** (2.2) in order to secure the cargo on the vehicle and that consists of a tensioning device, a tensioning element and connections, if required

NOTE 1 A tensioning device can be, for example, a belt or a strap.

NOTE 2 A tensioning element can be, for example, a wrench, a ratchet, or a spanner.

NOTE 3 Connections can be, for example, a hook or an eyelet.

1) See Reference [1].

**2.4
partitioning system**

device that fully or partially separates the occupant compartment from the loading space

EXAMPLE Partition, bulkhead, grid.

**2.5
protection zone**

area behind each seating position, for which special requirements for the protection against shifting cargo apply, limited to the area of vertical longitudinal sections, symmetrical to the left and right of the relevant R-points, with a width of 544 mm per seat and extending over the entire height of the occupant compartment

NOTE 1 In the case of a bench, the protection zones between the R-points can overlap.

NOTE 2 See ISO 6549 for further information on R-points.

**2.6
roadworthy**

design concept aiming at excluding harm to occupants of a road vehicle travelling on public roads under normal conditions of operation, such as full braking, emergency braking, braking in a curve, fast lane changing and driving in a curve

NOTE The concept of "harm" includes injuries and fatality.

3 Requirements

iTeh STANDARD PREVIEW
(standards.iteh.ai)

3.1 General requirements

In order to prevent cargo from penetrating into the occupant compartment, delivery vans shall be equipped with adequate devices to protect the occupants against the cargo. Therefore, protection devices consisting of a **partitioning system** (see 2.4) and **lashing points** (see 2.2) shall be provided.

3.2 Partitioning system

The **partitioning system** (see 2.4) shall fully separate the occupant compartment from the loading space, in terms of width and height. In the case of a loading space above the occupant compartment, the partitioning system may be limited in height to the horizontal separation between the occupant compartment and that loading space. However, in the case of a vehicle having a driver seat only and no passenger seat, the partitioning system does not need to cover the entire width of the vehicle, provided that the driver's **protection zone** (see 2.5) is covered and, in addition, the driver seating position is sufficiently protected against laterally shifting cargo.

If there is a gap between the partitioning system and the vehicle body this shall not be more than 40 mm (see Figure 2) without removing the covering (or trim), if any. A larger value is permissible in the case of corrugations in the side walls, as well as in order to ensure proper deployment of curtain airbags, if fitted.

If the partitioning system consists of a grid or cargo net, a rigid test device (e.g. rod), having a front surface of (50 × 10) mm moved in longitudinal direction (parallel to the x-axis of the vehicle), shall not be able to pass such nets or grids in any orientation (rotation around the x-axis).

The strength of the entire partitioning system shall be tested in accordance with 4.1.2. The **protection zone(s)** (see 2.5) of the partitioning system shall withstand testing in accordance with 4.1.3.

Each point within the protection zones shall meet the requirements of a test using the type 2 plunger piston (see 4.1.3). If windows or a door are located in the protection zone, such elements shall also withstand this test. The window material may fracture, as long as the deformation criteria given below are met.

Permanent deformations of the partitioning system up to 300 mm (see Figure 1) are permissible when tested in accordance with 4.1.2 or 4.1.3, as long as such deformations do not cause sharp edges or other deformations which might result directly or indirectly in injuries to the occupants.

Dimensions in millimetres

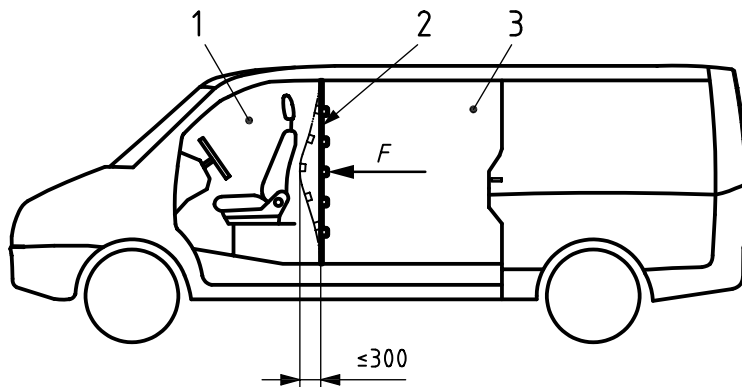

Key

- 1 occupant compartment
- 2 partitioning system
- 3 loading space
- F* test force

iTeh STANDARD PREVIEW
 (standards.iteh.ai)

Figure 1 — Partitioning system

ISO 27956:2009

<https://standards.iteh.ai/catalog/standards/sist/662ec008-f91d-48e9-b8b9-6d70f767742a/iso-27956-2009>

Dimensions in millimetres

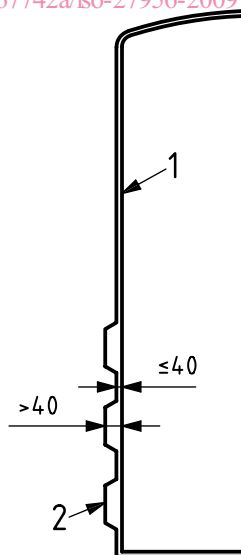

Key

- 1 partitioning system
- 2 corrugation in side wall

Figure 2 — Detail of partitioning system

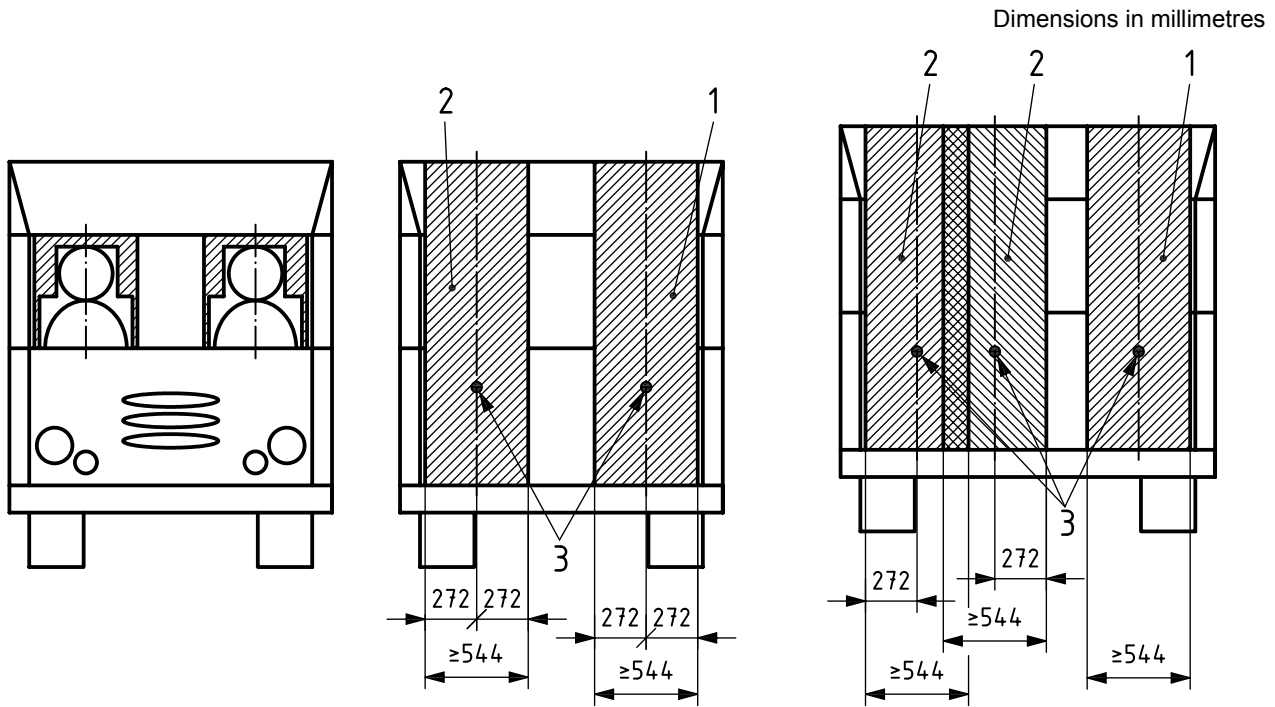

a) Example of a 2-seater occupant compartment

b) Example of a 3-seater occupant compartment

Key

- 1 driver's protection zone
- 2 passenger's protection zone
- 3 R-point

iTech STANDARD PREVIEW
(standards.iteh.ai)

ISO 27956:2009

<https://standards.iteh.ai/catalog/standards/sist/662ec008-f91d-48e9-b8b9-6d70f767742a/iso-27956-2009>

Figure 3 — Protection zones

3.3 Lashing points

3.3.1 General

The loading space of delivery vans shall be equipped with lashing points.

3.3.2 Design

3.3.2.1 The geometry of the lashing points is not specified in this International Standard, but is decided by the vehicle manufacturer. Examples of typical designs of lashing points are shown in Figure 4. Whatever design is selected by the vehicle manufacturer, the clearance of the lashing point shall be such that it shall be possible to insert through the opening of the lashing point a cylindrical probe with a diameter, d_1 , as specified in Table 1.

Table 1

Diameter of cylindrical probe to be inserted d_1 mm	Gross vehicle mass m_{GVM} t
35	$5,0 < m_{GVM} \leq 7,5$
25	$2,5 < m_{GVM} \leq 5,0$
20	$m_{GVM} \leq 2,5$

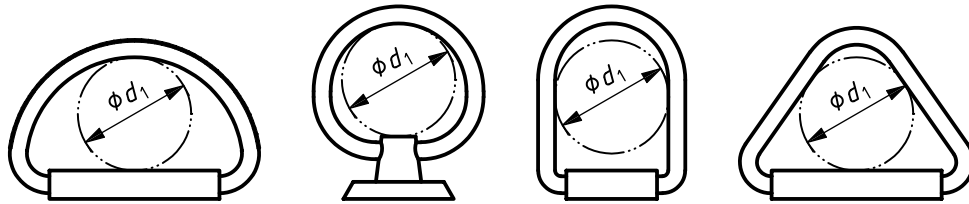
**Key**

d_1 diameter of cylindrical probe to be inserted

Figure 4 — Examples of typical designs of lashing points

3.3.2.2 The maximum cross section of the loop/ring must not be greater than 18 mm (see Figure 5). If the lashing point consists of a different design or other dimension, the vehicle manufacturer shall provide the adequate fastening elements.

Dimensions in millimetres

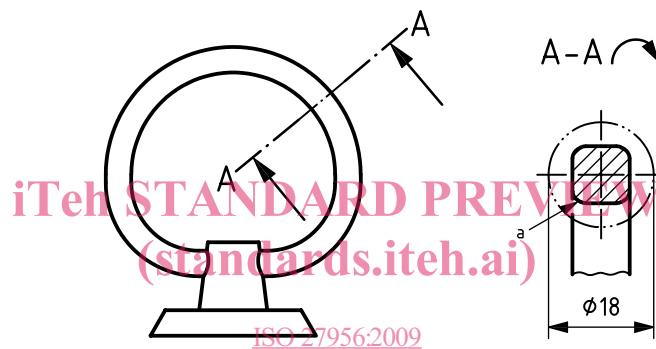
**Key**

^a Cross section \leq 18 mm.

Figure 5 — Maximum cross section of lashing loops/rings

3.3.3 Strength of lashing points

3.3.3.1 Each lashing point shall be designed for one of the categories of nominal tension force, F_N , calculated in accordance with Table 2, and shall withstand the test force applied under any angle in the range between 0° and 60° to the vertical (see Figure 12) during the test specified in 4.2.1.

3.3.3.2 The strength of the lashing points is proven if the tests specified in 4.2.1 are passed.