



Designation: D 4595 – 05

Standard Test Method for Tensile Properties of Geotextiles by the Wide-Width Strip Method¹

This standard is issued under the fixed designation D 4595; the number immediately following the designation indicates the year of original adoption or, in the case of revision, the year of last revision. A number in parentheses indicates the year of last reapproval. A superscript epsilon (ϵ) indicates an editorial change since the last revision or reapproval.

1. Scope

1.1 This test method covers the measurement of tensile properties of geotextiles using a wide-width strip specimen tensile method. This test method is applicable to most geotextiles that include woven fabrics, nonwoven fabrics, layered fabrics, knit fabrics, and felts that are used for geotextile application.

1.2 This test method covers the measurement of tensile strength and elongation of geotextiles and includes directions for the calculation of initial modulus, offset modulus, secant modulus, and breaking toughness.

1.3 Procedures for measuring the tensile properties of both conditioned and wet geotextiles by the wide-width strip method are included.

1.4 The basic distinction between this test method and other methods for measuring strip tensile properties is the width of the specimen. This width, by contrast, is greater than the length of the specimen. Some fabrics used in geotextile applications have a tendency to contract (neck down) under a force in the gage length area. The greater width of the specimen specified in this test method minimizes the contraction effect of those fabrics and provides a closer relationship to expected geotextile behavior in the field and a standard comparison.

1.5 *This standard does not purport to address all of the safety concerns, if any, associated with its use. It is the responsibility of the user of this standard to establish appropriate safety and health practices and determine the applicability of regulatory limitations prior to use.*

2. Referenced Documents

2.1 *ASTM Standards:*²

D 76 Specification for Tensile Testing Machines for Textiles

D 123 Terminology Relating to Textiles

D 579 Specification for Greige Woven Glass Fabrics

D 1776 Practice for Conditioning Textiles for Testing

D 2905 Practice for Statements on Number of Specimens for Textiles

D 4439 Terminology for Geosynthetics

3. Terminology

3.1 *atmosphere for testing geotextiles, n.*—air maintained at a relative humidity of $65 \pm 5\%$ and a temperature of $21 \pm 2^\circ\text{C}$ ($70 \pm 4^\circ\text{F}$).

3.2 *breaking toughness, T, (FL⁻¹), Jm⁻², n.*—for geotextiles, the actual work-to-break per unit surface area of material.

3.2.1 *Discussion*—Breaking toughness is proportional to the area under the force – elongation curve from the origin to the breaking point (see also work-to-break). Breaking toughness is calculated from work-to-break, gage length, and width of a specimen.

3.3 *corresponding force, F_c, n.*—the force associated with a specific elongation on the force-per-unit-width strain curve. (Syn. load at specified elongation, LASE.)

3.4 *geotechnical engineering, n.*—the engineering application of geotechnics.

3.5 *geotechnics, n.*—the application of scientific methods and engineering principles to the acquisition, interpretation, and use of knowledge of materials of the earth's crust to the solution of engineering problems.

3.5.1 *Discussion*—Geotechnics embraces the fields of soil mechanics, rock mechanics, and many of the engineering aspects of geology, geophysics, hydrology, and related sciences.

3.6 *geotextile, n.*—any permeable textile material used with foundation, soil, rock, earth, or any other geotechnical engineering related material, as an integral part of a man-made project, structure, or system.

3.7 *initial tensile modulus, J_i, (FL⁻¹), Nm⁻¹, n.*—for geotextiles, the ratio of the change in tensile force per unit width to a change in strain (slope) of the initial portion of a force per unit width strain curve.

¹ This test method is under the jurisdiction of ASTM Committee D35 on Geosynthetics and is the direct responsibility of Subcommittee D35.01 on Mechanical Properties.

Current edition approved Aug. 15, 2005. Published September 2005. Originally approved in 1986. Last previous edition approved in 2001 as D4595–86(2001).

² For referenced ASTM standards, visit the ASTM website, www.astm.org, or contact ASTM Customer Service at service@astm.org. For *Annual Book of ASTM Standards* volume information, refer to the standard's Document Summary page on the ASTM website.

3.8 *offset tensile modulus, J_o , (FL^{-1}), Nm^{-1} , n .*—for *geotextiles*, the ratio of the change in force per unit width to a change in strain (slope) below the proportional limit point and above the tangent point on the force – elongation curve.

3.9 *proportional limit, n .*—the greatest stress which a material is capable of sustaining without any deviation from proportionality of stress to strain (Hooke’s law).

3.10 *secant tensile modulus, J_{sec} (FL^{-1}), Nm^{-1} , n .*—for *geotextiles*, the ratio of change in force per unit width to a change in strain (slope) between two points on a force per unit width strain curve.

3.11 *tangent point, n .*—for *geotextiles*, the first point of the force – elongation curve at which a major decrease in slope occurs.

3.11.1 *Discussion*—The tangent point is determined by drawing a tangent line passing through the zero axis and the proportional elastic limit. The point from the zero force axis that the force – elongation curve first touches that tangent line is the tangent point.

3.12 *tensile modulus, J , (FL^{-1}), Nm^{-1} , n .*—for *geotextiles*, the ratio of the change in tensile force per unit width to a corresponding change in strain (slope).

3.13 *tensile strength, n .*—for *geotextiles*, the maximum resistance to deformation developed for a specific material when subjected to tension by an external force.

3.13.1 *Discussion*—Tensile strength of geotextiles is the characteristic of a sample as distinct from a specimen and is expressed in force per unit width.

3.14 *tensile test, n .*—in *textiles*, a test in which a textile material is stretched in one direction to determine the force – elongation characteristics, the breaking force, or the breaking elongation.

3.15 *wide-width strip tensile test, n .*—for *geotextiles*, a uniaxial tensile test in which the entire width of a 200-mm (8.0-in.) wide specimen is gripped in the clamps and the gage length is 100 mm (4.0 in.).

3.16 *work-to-break, W , (LF), n .*—in *tensile testing*, the total energy required to rupture a specimen.

3.16.1 *Discussion*—For geotextiles, work-to-break is proportional to the area under the force – elongation curve from the origin to the breaking point, and is commonly expressed in joules (inch-pound-force).

3.17 *yield point, n .*—the first point of the force – elongation curve above the proportional (linear) section at which an increase in elongation occurs without a corresponding increase in force.

3.18 For terminology of other terms used in this test method, refer to Terminology **D 123** and Terminology **D 4439**.

4. Summary of Method

4.1 A relatively wide specimen is gripped across its entire width in the clamps of a constant rate of extension (CRE) type tensile testing machine operated at a prescribed rate of extension, applying a longitudinal force to the specimen until the specimen ruptures. Tensile strength, elongation, initial and secant modulus, and breaking toughness of the test specimen can be calculated from machine scales, dials, recording charts, or an interfaced computer.

5. Significance and Use

5.1 The determination of the wide-width strip force – elongation properties of geotextiles provides design parameters for reinforcement type applications, for example design of reinforced embankments over soft subgrades, reinforced soil retaining walls, and reinforcement of slopes. When strength is not necessarily a design consideration, an alternative test method may be used for acceptance testing. Test Method D 4595 for the determination of the wide-width strip tensile properties of geotextiles may be used for the acceptance testing of commercial shipments of geotextiles but caution is advised since information about between-laboratory precision is incomplete (**Note 6**). Comparative tests as directed in **5.1.1** may be advisable.

5.1.1 In cases of a dispute arising from differences in reported test results when using Test Method D 4595 for acceptance testing of commercial shipments, the purchaser and the supplier should conduct comparative tests to determine if there is a statistical bias between their laboratories. Competent statistical assistance is recommended for the investigation of bias. As a minimum, the two parties should take a group of test specimens which are as homogeneous as possible and which are from a lot of material of the type in question. The test specimens should then be randomly assigned in equal numbers to each laboratory for testing. The average results from the two laboratories should be compared using Student’s *t*-test for unpaired data and an acceptable probability level chosen by the two parties before the testing began. If a bias is found, either its cause must be found and corrected or the purchaser and the supplier must agree to interpret future test results in the light of the known bias.

5.2 Most geotextiles can be tested by this test method. Some modification of clamping techniques may be necessary for a given geotextile depending upon its structure. Special clamping adaptations may be necessary with strong geotextiles or geotextiles made from glass fibers to prevent them from slipping in the clamps or being damaged as a result of being gripped in the clamps. Specimen clamping may be modified as required at the discretion of the individual laboratory providing a representative tensile strength is obtained. In any event, the procedure described in Section **10** of this test method for obtaining wide-width strip tensile strength must be maintained.

5.3 This test method is applicable for testing geotextiles either dry or wet. It is used with a constant rate of extension type tension apparatus.

5.4 The use of tensile strength test methods that restrict the *clamped* width dimension to 50 mm (2 in.) or less, such as the ravel, cut strip, and grab test procedures, have been found less suitable than this test method for determining design strength parameters for some geotextiles. This is particularly the case for nonwoven geotextiles. The wide-width strip technique has been explored by the industry and is recommended in these cases for geotextile applications.

5.4.1 This test method may not be suited for some woven fabrics used in geotextile applications that exhibit strengths approximately 100 kN/m or 600 lbf/in. due to clamping and equipment limitations. In those cases, 100-mm (4-in.) width

specimens may be substituted for 200-mm (8-in.) width specimens. On those fabrics, the contraction effect cited in 1.4 is minimal and, consequently, the standard comparison can continue to be made.

6. Apparatus and Reagents

6.1 *Tensile Testing Machine*—A constant rate of extension (CRE) type of testing machine described in Specification D 76 shall be used. When using the CRE type tensile tester, the recorder must have adequate pen response to properly record the force—elongation curve as specified in Specification D 76.

6.2 *Clamps*—The clamps shall be sufficiently wide to grip the entire width of the sample and with appropriate clamping power to prevent slipping or crushing (damage).

6.2.1 Two basic clamp designs are shown in Fig. 1, Fig. 2, Fig. 3, and Fig. 4. These designs have been used in the laboratory and have provided reproducible tensile strengths. These clamps may be modified to provide greater ease and speed of clamping. In any event, caution must be taken to ensure the type material and dimensions of the clamp are adequate for the user's expected fabric strength.

6.2.2 *Size of Jaw Faces*—Each clamp shall have jaw faces measuring wider than the width of the specimen, 200 mm (8 in.), and a minimum of 50-mm (2-in.) length in the direction of the applied force.

6.3 *Area-Measuring Device*—Use an integrating accessory to the tensile testing machine or a planimeter.

6.4 *Distilled Water and Nonionic Wetting Agent*, for wet specimens only.

7. Sampling

7.1 *Lot Sample*—For the lot sample, take rolls of geotextiles as directed in an applicable material specification, or as agreed upon between the purchaser and the supplier.

NOTE 1—The extent of the sampling for wide-width strip tensile properties is generally defined in an applicable order or contract. Among the options available to the purchaser and the supplier is for the purchaser to accept certification by the manufacturer that the material in question meets the requirements agreed upon by the two parties, and what the basis for the certification is, such as, historical data generated from material manufactured under the same conditions.

7.2 *Laboratory Sample*—For the laboratory sample, take a full-width swatch approximately 1 m (40 in.) long in the

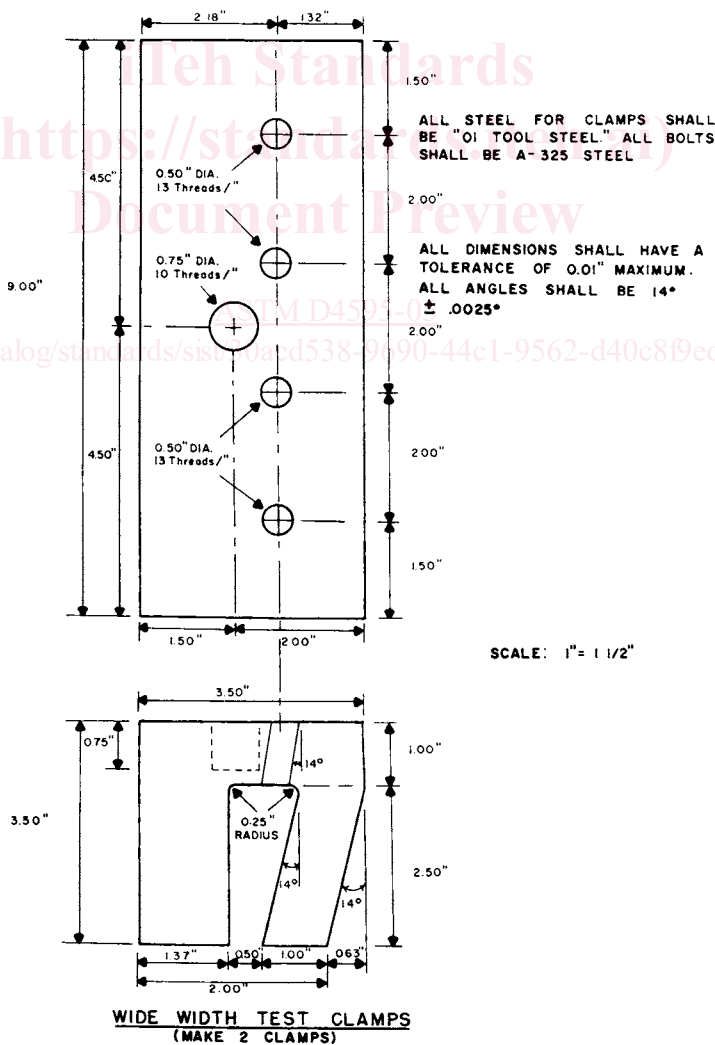

FIG. 1 Wide Width Test Clamps

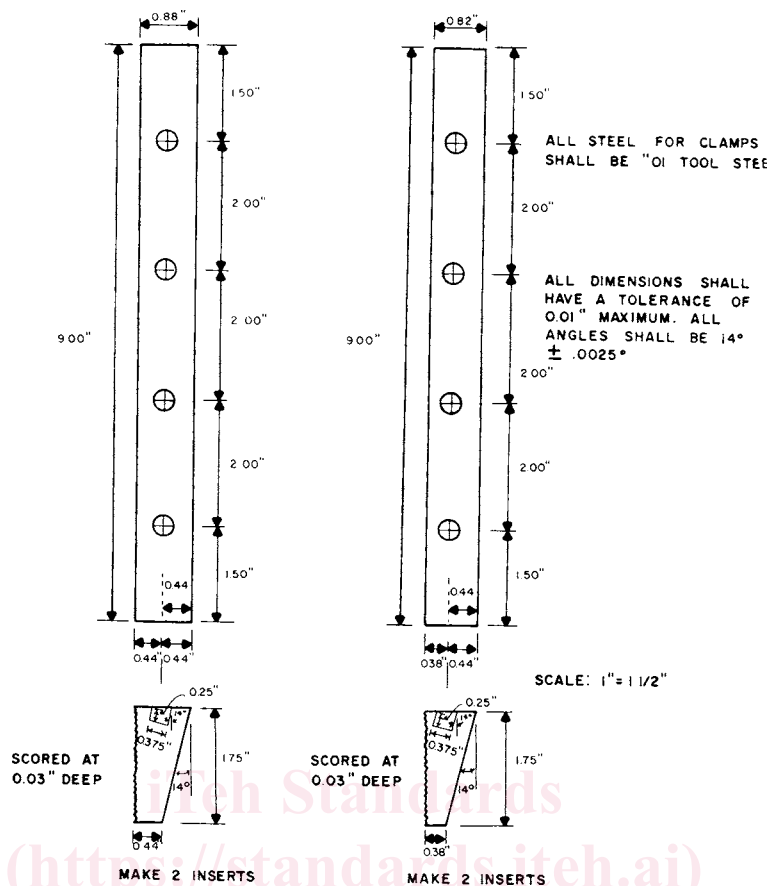

FIG. 2 Inserts for Wide Width Clamps

machine direction from each roll in the lot sample. The sample may be taken from the end portion of a roll provided there is no evidence it is distorted or different from other portions of the roll. In cases of dispute, take a sample that will exclude fabric from the outer wrap of the roll or the inner wrap around the core.

7.3 *Test Specimens*—For tests in the machine direction and the cross-machine direction, respectively, take from each swatch in the laboratory sample the number of specimens directed in Section 8. Take specimens at random from the laboratory sample, with those for the measurement of the machine direction tensile properties from different positions across the geotextile width, and the specimens for the measurement of the cross-machine direction tensile properties from different positions along the length of the geotextile. Take no specimens nearer the selvage or edge of the geotextile than 1/10 the width of the geotextile (see 8.2).

8. Test Specimen Preparation

8.1 Number of Specimens:

8.1.1 Unless otherwise agreed upon, as when specified in an applicable material specification, take a number of specimens per fabric swatch such that the user may expect at the 95 % probability level that the test result is not more than 5.0 % of the average above or below the true average of the swatch for

each, the machine and cross-machine direction, respectively. Determine the number of specimens as follows:

8.1.1.1 *Reliable Estimate of v*—When there is a reliable estimate of *v* based upon extensive past records for similar materials tested in the user’s laboratory as directed in the method, calculate the required number of specimens using Eq 1, as follows:

$$n = (tv/A)^2 \tag{1}$$

where:

- n* = number of specimens (rounded upward to a whole number),
- v* = reliable estimate of the coefficient of variation of individual observations on similar materials in the user’s laboratory under conditions of single-operator precision, %,
- t* = the value of Student’s *t* for one-sided limits (see Table 1), a 95 % probability level, and the degrees of freedom associated with the estimate of *v*, and
- A* = 5.0 % of the average, the value of the allowable variation.

8.1.1.2 *No Reliable Estimate of v*—When there is no reliable estimate of *v* for the user’s laboratory, Eq 1 should not be used directly. Instead, specify the fixed number of six specimens for each the machine direction and the cross-machine

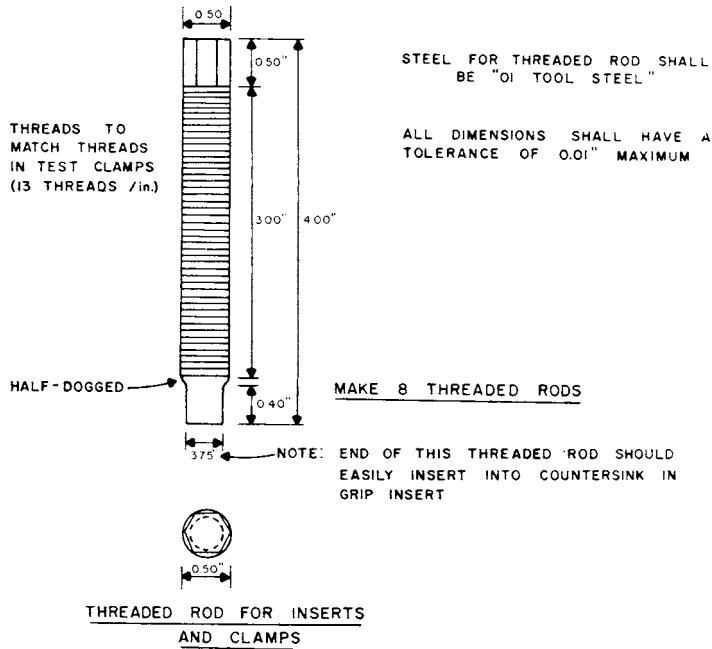

FIG. 3 End View of Composite of Clamp, Insert, and Threaded Rod

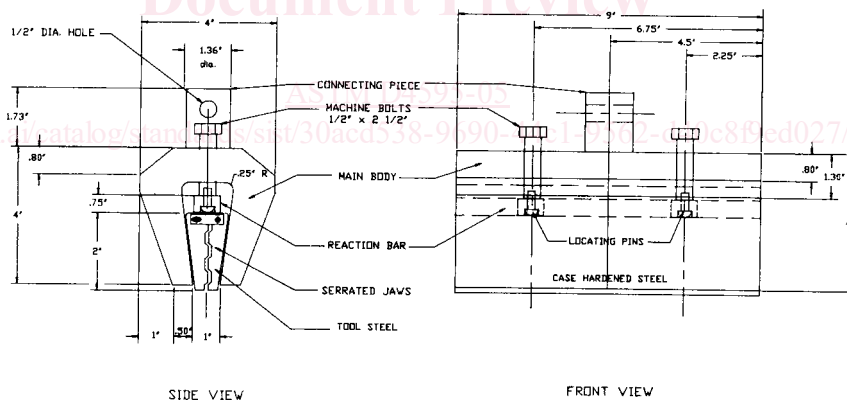

FIG. 4 Sanders Clamp

direction tests. The number of specimens is calculated using $v = 7.4\%$ of the average. This value for v is somewhat larger than usually found in practice. When a reliable estimate of v for the user's laboratory becomes available, Eq 1 will usually require fewer than the fixed number of specimens.

8.2 Test Specimen Size:

8.2.1 Prepare each finished specimen 200-mm (8.0-in.) wide (excluding fringe when applicable, see 8.2.2) by at least 200-mm (8.0-in.) long (see 8.2.2) with the length dimension being designated and accurately parallel to the direction for which the tensile strength is being measured. Centrally, draw

two lines running the full width of the specimen, accurately perpendicular to the length dimension and separated by 100 mm (4 in.) to designate the gage area (See Note 6).

8.2.2 For some woven geotextiles, it may be necessary to cut each specimen 210-mm (8.5-in.) wide and then remove an equal number of yarns from each side to obtain the 200 mm (8.0 in.) finished dimension. This helps maintain specimen integrity during the test.

TABLE 1 Values of Student's *t* for One-Sided Limits and the 95 % Probability^A

df	One-Sided	df	One-Sided	df	One-Sided
1	6.314	11	1.796	22	1.717
2	2.920	12	1.782	24	1.711
3	2.353	13	1.771	26	1.706
4	2.132	14	1.761	28	1.701
5	2.015	15	1.753	30	1.697
6	1.943	16	1.746	40	1.684
7	1.895	17	1.740	50	1.676
8	1.860	18	1.734	60	1.671
9	1.833	19	1.729	120	1.658
10	1.812	20	1.725	∞	1.645

^A Values in this table were calculated using Hewlett Packard HP 67/97 Users' Library Programs 03B48D, "One-Sided and Two-Sided Critical Values of Student's *t*" and 00350D, "Improved Normal and Inverse Distribution." For values at other than the 95 % probability level, see published tables of critical values of Student's *t* in any standard statistical text. Further use of this table is defined in Practice **D 2905**.

8.2.3 The length of the specimen depends upon the type of clamps being used. It must be long enough to extend through the full length of both clamps, as determined for the direction of test.

8.2.4 When specimen integrity is not affected, the specimens may be initially cut to the finished width.

8.2.5 When the wet tensile strength of the fabric is required in addition to the dry tensile strength, cut each test specimen at least twice as long as is required for a standard test (see **Note 1**). Number each specimen and then cut it crosswise into two parts, one for determining the conditioned tensile strength and the other for determining the wet tensile strength; each portion shall bear the specimen number. In this manner, each paired break is performed on test specimens containing the same yarns.

NOTE 2—For geotextiles which shrink excessively when wet, cut the test specimens for obtaining wet tensile strength longer in dimension than that for dry tensile strength.

9. Conditioning

9.1 Bring the specimens to moisture equilibrium in the atmosphere for testing geotextiles. Equilibrium is considered to have been reached when the increase in mass of the specimen in successive weighings made at intervals of not less than 2 h does not exceed 0.1 % of the mass of the specimen. In general practice, the industry approaches equilibrium from the "as received" side.

NOTE 3—It is recognized that in practice, geotextile materials are frequently not weighed to determine when moisture equilibrium has been reached. While such a procedure cannot be accepted in cases of dispute, it may be sufficient in routine testing to expose the material to the standard atmosphere for testing for a reasonable period of time before the specimens are tested. A time of at least 24 h has been found acceptable in most cases. However, certain fibers may exhibit slow moisture equalization rates from the "as received" wet side. When this is known, a preconditioning cycle, as described in Practice **D 1776**, may be agreed upon between contractual parties.

9.2 Specimens to be tested in the wet condition shall be immersed in water, maintained at a temperature of $21 \pm 2^\circ\text{C}$ ($70 \pm 4^\circ\text{F}$). The time of immersion must be sufficient to wet-out the specimens thoroughly, as indicated by no significant change in strength or elongation following a longer period of

immersion, and at least 2 min. To obtain thorough wetting, it may be necessary or advisable to add not more than 0.05 % of a nonionic neutral wetting agent to the water.

10. Procedure

10.1 *Conditioned Specimens*—Test adequately conditioned specimens in the atmosphere for testing geotextiles.

10.2 *Wet Specimens*—Test thoroughly wet specimens in the normal machine set-up within 20 min after removal from the water.

10.3 *Machine Set-Up Conditions*—Adjust the distance between the clamps at the start of the test at 100 ± 3 mm (4 ± 0.1 in.). At least one clamp should be supported by a free swivel or universal joint which will allow the clamp to rotate in the plane of the fabric. Select the force range of the testing machine so the break occurs between 10 and 90 % of full-scale force. Set the machine to a strain rate of 10 ± 3 %/min.

NOTE 4—It is recognized that some tensile tests on geotextiles are conducted using a manually applied strain rate. In that case, approximately a 2 %/min strain rate should be used. In any event, the strain rate described in **10.3** is preferred.

10.4 *Insertion of Specimen in Clamps*—Mount the specimen centrally in the clamps. Do this by having the two lines, which were previously drawn 100 ± 3 mm (4.0 ± 0.1 in.) apart across the width of the specimen positioned adjacent to the inside edges of the upper and lower jaw. The specimen length in the machine direction and cross-machine direction tests, respectively, must be parallel to the direction of application of force.

10.5 *Measurement of Tensile Strength*—Start the tensile testing machine and the area measuring device, if used, and continue running the test to rupture. Stop the machine and reset to the initial gage position. Record and report the test results to three significant figures for each direction separately (See **Note 6**).

10.5.1 If a specimen slips in the jaws, breaks at the edge of or in the jaws, or if for any reason attributed to faulty operation the result falls markedly below the average for the set of specimens, discard the result and test another specimen. Continue until the required number of acceptable breaks have been obtained.

10.5.2 The decision to discard the results of a break shall be based on observation of the specimen during the test and upon the inherent variability of the fabric. In the absence of other criteria for rejecting a so-called jaw break, any break occurring within 5 mm ($1/4$ in.) of the jaws which results in a value below 20 % of the average of all the other breaks shall be discarded. No other break shall be discarded unless the test is known to be faulty.

10.5.3 It is difficult to determine the precise reason why certain specimens break near the edge of the jaws. If a jaw break is caused by damage to the specimen by the jaws, then the results should be discarded. If, however, it is merely due to randomly distributed weak places, it is a perfectly legitimate result. In some cases, it may also be caused by a concentration of stress in the area adjacent to the jaws because they prevent the specimen from contracting in width as the force is applied.