



Designation: D 6928 – 06

Standard Test Method for Resistance of Coarse Aggregate to Degradation by Abrasion in the Micro-Deval Apparatus¹

This standard is issued under the fixed designation D 6928; the number immediately following the designation indicates the year of original adoption or, in the case of revision, the year of last revision. A number in parentheses indicates the year of last reapproval. A superscript epsilon (ϵ) indicates an editorial change since the last revision or reapproval.

1. Scope

1.1 This method covers a procedure for testing coarse aggregate for resistance to abrasion using the Micro-Deval apparatus.

1.2 The values stated in SI units are to be regarded as the standard.

1.3 The text of this method references notes and footnotes which provide explanatory material. These notes and footnotes (excluding those in tables and figures) shall not be considered as requirements of the test method.

1.4 *This procedure may involve hazardous materials, operations, and equipment. This standard does not purport to address all of the safety concerns, if any, associated with its use. It is the responsibility of the user of this standard to establish appropriate safety and health practices and determine the applicability of regulatory limitations prior to use.*

2. Referenced Documents

2.1 *ASTM Standards:*²

C 136 Test Method for Sieve Analysis of Fine and Coarse Aggregates

C 670 Practice for Preparing Precision and Bias Statements for Test Methods for Construction Materials

E 11 Specification for Wire Cloth and Sieves for Testing Purposes

3. Terminology

3.1 *Definitions:*

3.1.1 *constant mass, n*—test samples dried at a temperature of $110 \pm 5^\circ\text{C}$ to a condition such that it will not lose more than 0.1 % moisture after 2 h of drying. Such a condition of dryness can be verified by weighing the sample before and after

successive 2-h drying periods. In lieu of such a determination, samples may be considered to have reached constant mass when they have been dried at a temperature of $110 \pm 5^\circ\text{C}$ for an equal or longer period than that previously found adequate for producing the desired constant mass condition under equal or heavier loading conditions of the oven.

4. Summary of Test Method

4.1 The Micro-Deval Test is a measure of abrasion resistance and durability of mineral aggregates resulting from a combination of actions including abrasion and grinding with steel balls in the presence of water. A sample with standard grading is initially soaked in water for not less than one hour. The sample is then placed in a jar mill with 2.0 L of water and an abrasive charge consisting of 5000 g of 9.5-mm diameter steel balls. The jar, aggregate, water, and charge are revolved at 100 rpm for up to 2 h, depending on the particle size. The sample is then washed and oven dried. The loss is the amount of material passing the 1.18-mm sieve expressed as a percent by mass of the original sample.

5. Significance and Use

5.1 The Micro-Deval abrasion test is a test of coarse aggregate to determine abrasion loss in the presence of water and an abrasive charge. Many aggregates are more susceptible when wet than dry, and the use of water in this test incorporates this reduction in resistance in degradation in contrast to some other tests, which are conducted on dry aggregate. The test results are helpful in evaluating the toughness/abrasion resistance of coarse aggregate subject to abrasion when adequate information is not available from service records.

5.2 The Micro-Deval abrasion test is useful for detecting changes in properties of aggregate produced from an aggregate source as part of a quality control or quality assurance process.

6. Apparatus

6.1 *Micro-Deval Abrasion Machine*, a jar rolling mill capable of running at 100 ± 5 rpm (Fig. 1).

6.2 *Containers*, stainless steel Micro-Deval abrasion jars having a 5-L capacity with a rubber ring in the rotary locking cover. External diameter of 194-mm to 202-mm. Internal

¹ This test method is under the jurisdiction of ASTM Committee D04 on Road and Paving Materials and is the direct responsibility of Subcommittee D04.51 on Aggregate Tests.

Current edition approved Jan. 1, 2006. Published January 2006. Originally approved in 2003. Last previous edition approved in 2003 as D 6928 – 03.

² For referenced ASTM standards, visit the ASTM website, www.astm.org, or contact ASTM Customer Service at service@astm.org. For *Annual Book of ASTM Standards* volume information, refer to the standard's Document Summary page on the ASTM website.

Dimensions in millimeters

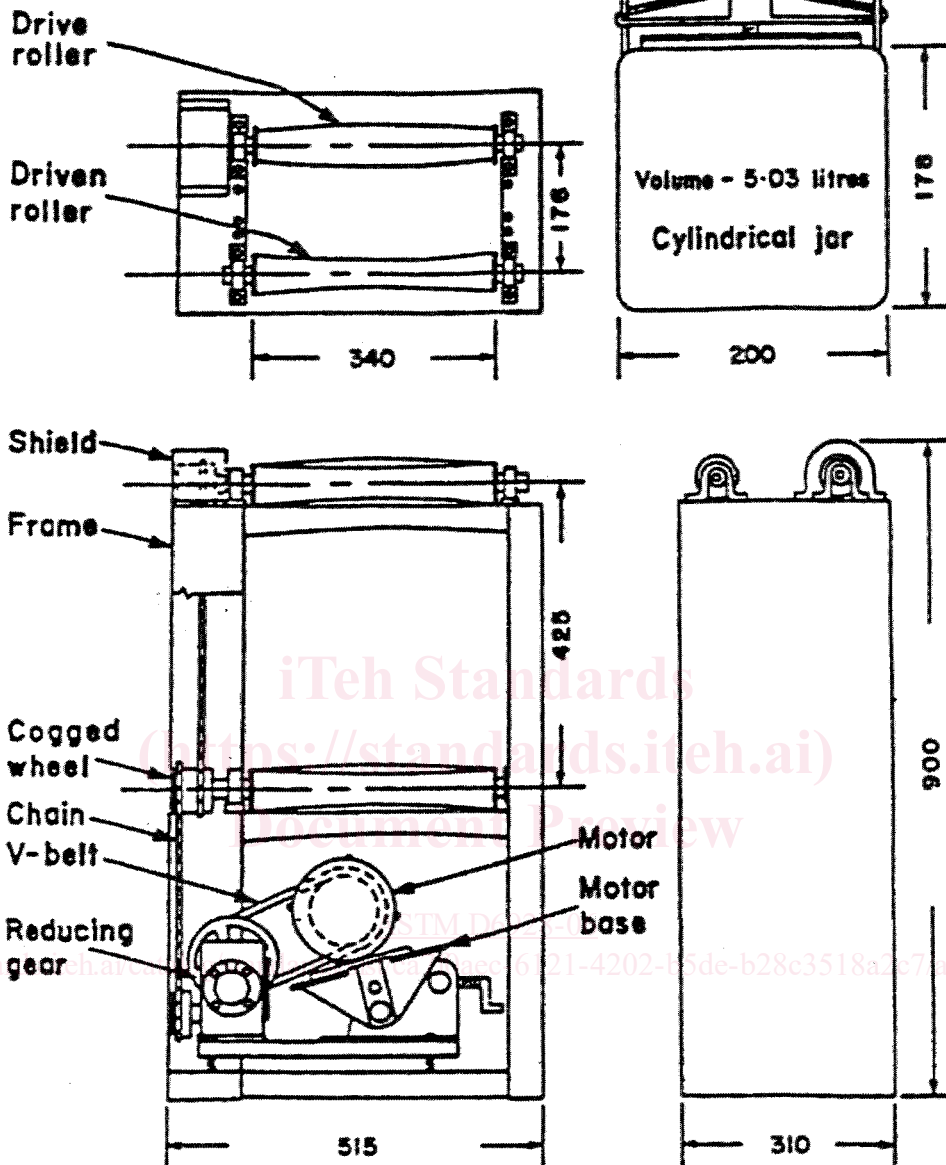

FIG. 1 Micro-Deval Abrasion Machine and Container

height of 170-mm to 177-mm. The inside and outside surfaces of the jars shall be smooth and have no observable ridges or indentations (Fig. 1).

6.3 *Abrasive Charge*—Magnetic stainless steel balls are required. These shall have a diameter of 9.5 ± 0.5 mm. Each jar requires a charge of 5000 ± 5 g of balls.

6.4 *Sieves*, with square openings, and of the following sizes conforming to Specification E 11 specifications: 19.0 mm, 16.0 mm, 12.5 mm, 9.5 mm, 6.7 mm, 6.3 mm, 4.75 mm, 1.18 mm.

6.5 *Oven*, capable of maintaining a temperature of $110 \pm 5^\circ\text{C}$.

6.6 *Balance*, or scale accurate to 1.0 g.

7. Supplies

7.1 *Laboratory Reference Aggregate*—A supply of standard “Brechin Quarry No. 2” coarse aggregate available from the Soils and Aggregates Section, Engineering Materials Office, Ministry of Transportation, 1201 Wilson Avenue, Downsview, Ontario, Canada M3M1J8. Fax: 1-416-235-4101.

7.2 *Calibration Aggregate*—An adequate supply of aggregate, established by the Laboratory to use for calibration of the test method (see 11.1).