



Standard Test Method for Cohesion/Adhesion of Sprayed Fire-Resistive Materials Applied to Structural Members¹

This standard is issued under the fixed designation E 736; the number immediately following the designation indicates the year of original adoption or, in the case of revision, the year of last revision. A number in parentheses indicates the year of last reapproval. A superscript epsilon (ϵ) indicates an editorial change since the last revision or reapproval.

This standard has been approved for use by agencies of the Department of Defense.

1. Scope

1.1 This test method covers a procedure for measuring the cohesion/adhesion or bond strength (tensile) perpendicular to the surface of sprayed fire-resistive material (SFRM) applied to rigid backing. These fire-resistive materials include sprayed fibrous and cementitious materials. The test method is applicable to both laboratory and field procedures as indicated in Section 7.

1.2 The values stated in SI units are to be regarded as the standard. The values in parentheses are for information only.

1.3 *This standard does not purport to address all of the safety problems, if any, associated with its use. It is the responsibility of the user of this standard to establish appropriate safety and health practices and determine the applicability of regulatory limitations prior to use.*

2. Referenced Documents

2.1 *ASTM Standards:*²

E 84 [Test Method for Surface Burning Characteristics of Building Materials](#)

E 119 [Test Methods for Fire Tests of Building Construction and Materials](#)

E 605 [Test Methods for Thickness and Density of Sprayed Fire-Resistive Material \(SFRM\) Applied to Structural Members](#)

3. Summary of Test Method

3.1 The cohesion/adhesion is determined using a metal or plastic cap with a hook attached. The cap is attached to the SFRM with a suitable adhesive. An increasing load, measured by a scale, is applied manually until failure occurs.

4. Significance and Use

4.1 The intent of this test method is to determine a property of SFRM that may be used to provide an indication of its in-place serviceability. Satisfactory performance of SFRM applied to structural members and assemblies depends upon its ability to withstand the various influences that may occur during construction and during the life of the structure, as well as upon its satisfactory performance under fire conditions.

5. Apparatus

5.1 Fig. 1 illustrates a suitable apparatus.

5.2 *Bottle Screw Cap*,³ metal or rigid plastic 51 mm to 83 mm (2 in. to 3¼ in.) in diameter and 12 mm (½ in.) in nominal depth. A hook shall be attached at the center. Where deck profile does not allow the use of an 83-mm (3¼-in.) diameter cap due to area restriction, a minimum 51-mm (2-in.) diameter cap shall be used.

5.3 *Adhesive*, single or two component, suitable for adhering cap to SFRM.⁴

5.4 *Weighing Scale*, spring type (fish hook), with a capacity suitable for the SFRM being tested (typically 12 kg to 30 kg (26 to 66 lb) capacity). The accuracy shall be within 0.1 kg (¼ lb).

5.5 *Galvanized Steel Sheet*, 1.5 mm (0.060 in. (16 ga)) thick, 300 mm (12 in.) square, cleaned with solvent to remove any oil from surface to be sprayed.

5.6 *Drying Oven*, capable of maintaining temperature and humidity conditions during the specimen curing cycle, in accordance

¹ This test method is under the jurisdiction of ASTM Committee E-6 E06 on Performance of Buildings and is the direct responsibility of Subcommittee E06.21 on Serviceability.

Current edition approved April 10, 2000. Published July 2000. Originally published as E736-80. Last previous edition E736-92.

Current edition approved Jan. 1, 2006. Published January 2006. Originally approved in 1980. Last previous edition approved in 2000 as E 736 – 00.

² For referenced ASTM standards, visit the ASTM website, www.astm.org, or contact ASTM Customer Service at service@astm.org. For *Annual Book of ASTM Standards* Vol 04.07-volume information, refer to the standard's Document Summary page on the ASTM website.

³ Refer to Appendix X1.2 for a list of bottle screw cap supply houses that have been found satisfactory for this purpose. Many local suppliers are also available.

⁴ Suitable adhesives are commercially available. Refer to Appendix X1.1 for a list of adhesive supply houses that have been found satisfactory for this purpose.

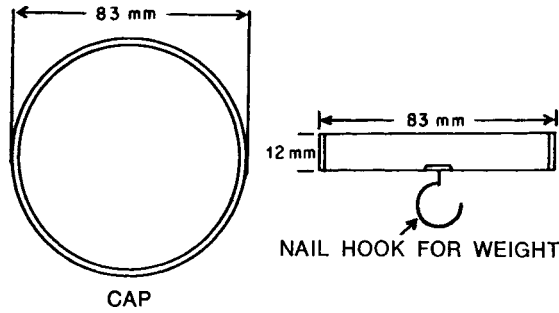

FIG. 1 Typical Cohesion/Adhesion Testing Apparatus

with the SFRM manufacturers' published requirements.

6. Sampling

6.1 This test method requires the application of SFRM in accordance with manufacturers' published instructions. The apparatus, materials, and procedures used to spray apply the SFRM for this test shall be representative of application in the field.

6.2 The density of the prepared specimens shall be similar to the density tested and reported during the Test Methods E119E 84 and E84E 119 fire exposure tests of the same material, or as required by the sponsor of the test.

6.3 Determine and report in accordance with Test Methods E 605 the density and thickness of each sample, or of a randomly selected specimen from the sample lot when a number of identical samples are being tested for the laboratory-prepared samples. For the field specimens, determine the density from material adjacent to the test specimen.

7. Test Specimen

7.1 Laboratory Tests:

7.1.1 The SFRM shall be applied at a thickness of 12 mm to 25 mm (½ in. to 1 in.) to the 300 by 300 mm (12 by 12 in.) galvanized steel sheet.

7.1.2 Condition the specimen at room temperature ($20 \pm 10^\circ\text{C}$ ($68 \pm 18^\circ\text{F}$)). After 72 h, samples may be force dried in a drying oven at $43 \pm 6^\circ\text{C}$ ($110 \pm 10^\circ\text{F}$), and a relative humidity not greater than 60 % until successive weight⁵ readings, taken at 8 h intervals, differ by less than 1 percent.

7.1.3 Testing may be performed after it has been determined that all samples have reached constant weight as defined in 7.1.2.

7.2 Field Tests:

7.2.1 The test specimen shall be the in-place SFRM as applied to any field condition surface. Where a 300- by 300-mm (12- by 12-in.) area is not available, such as on beams and fluted deck, use the width of the beam or the width of a flute by 300 mm (12 in.) length. The area shall be at least 100 by 300 mm (4 by 12 in.). See 5.2 for exceptions.

7.2.2 Condition the specimen at atmospheric conditions or in accordance with the manufacturers' recommendations for a period sufficient to be considered dry.

7.2.3 Mechanical ventilation may be employed on the manufacturers' recommendation to expedite drying.

8. Procedure

8.1 Apply adhesive sufficient to fill the metal or plastic cap, and immediately place the cap against the surface of the SFRM. Refer to Fig. 2.

8.2 Support the cap at the surface until the adhesive has adequately cured. Wipe away any excess adhesive around the cap before it cures, or carefully cut it away after it cures.

8.3 Laboratory Tests:

⁵ Although *mass* is being determined, the term *weight* is used in the test method as an accepted substitute.

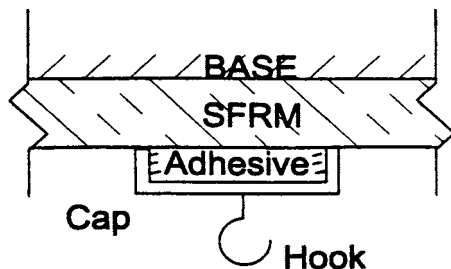

FIG. 2 In-Place Apparatus