



# Standard Specification for Solvent Cements for Transition Joints Between Acrylonitrile- Butadiene-Styrene (ABS) and Poly(Vinyl Chloride) (PVC) Non-Pressure Piping Components<sup>1</sup>

This standard is issued under the fixed designation D 3138; the number immediately following the designation indicates the year of original adoption or, in the case of revision, the year of last revision. A number in parentheses indicates the year of last reapproval. A superscript epsilon ( $\epsilon$ ) indicates an editorial change since the last revision or reapproval.

## 1. Scope

1.1 This specification provides general requirements for solvent cements used in joining acrylonitrile-butadiene-styrene (ABS) plastic pipe or fittings to poly(vinyl chloride) (PVC) plastic pipe or fittings.

1.2 These cements are intended for use in cementing transition joints between ABS and PVC materials in non-pressure applications only (25 psi (170 kPa) or less).

NOTE 1—This specification was developed to provide a means for joining an ABS non-pressure piping system using a solvent-cemented transition joint, for example, joining ABS building drain to a PVC sewer system. The intention was not to create a specification for an all purpose ABS-PVC solvent cement that would be used for mixing of ABS and PVC piping materials nor to specify a cement that could generally be used for either material. Specific cements for ABS or PVC components should be used (see 1.3).

1.3 Solvent cements used for joining PVC pipe and fittings are specified in Specification D 2564. Solvent cements used for joining ABS pipe and fittings are specified in Specification D 2235.

1.4 A recommended procedure for joining ABS to PVC pipe and fittings for non-pressure applications is given in the appendix.

1.5 The values stated in inch-pound units are to be regarded as the standard. The values given in parentheses are for information only.

1.6 The following safety hazards caveat pertains only to the test methods portion, Section 6, of this specification: *This standard does not purport to address all of the safety concerns, if any, associated with its use. It is the responsibility of the user of this standard to establish appropriate safety and health practices and determine the applicability of regulatory limitations prior to use.*

## 2. Referenced Documents

### 2.1 ASTM Standards:

D 1084 Test Methods for Viscosity of Adhesives<sup>2</sup>

<sup>1</sup> This specification is under the jurisdiction of ASTM Committee F-17 on Plastic Piping Systems and is the direct responsibility of Subcommittee F17.20 on Joining. Current edition approved Sept. 10, 1995. Published November 1995. Originally published as D 3138 – 72. Last previous edition D 3138 – 93.

<sup>2</sup> Annual Book of ASTM Standards, Vol 15.06.

D 1600 Terminology for Abbreviated Terms Relating to Plastics<sup>3</sup>

D 1784 Specification for Rigid Poly(Vinyl Chloride) (PVC) Compounds and Chlorinated Poly(Vinyl Chloride) (CPVC) Compounds<sup>3</sup>

D 2235 Specification for Solvent Cement for Acrylonitrile-Butadiene-Styrene (ABS) Plastic Pipe and Fittings<sup>3</sup>

D 2564 Specification for Solvent Cements for Poly(Vinyl Chloride) (PVC) Plastic Piping Systems<sup>3</sup>

D 2661 Specification for Acrylonitrile-Butadiene-Styrene (ABS) Plastic Drain, Waste, and Vent Pipe and Fittings<sup>3</sup>

D 2665 Specification for Poly(Vinyl Chloride) (PVC) Plastic Drain, Waste, and Vent Pipe and Fittings<sup>3</sup>

F 402 Practice for Safe Handling of Solvent Cements, Primers, and Cleaners Used for Joining Thermoplastic Pipe and Fittings<sup>3</sup>

F 412 Terminology Relating to Plastic Piping Systems<sup>3</sup>

F 493 Specification for Solvent Cements for Chlorinated Poly(Vinyl Chloride) (CPVC) Plastic Pipe and Fittings<sup>3</sup>

## 3. Terminology

3.1 *Definitions:* Definitions are in accordance with Terminology F 412, and abbreviations are in accordance with Terminology D 1600, unless otherwise specified.

## 4. Materials and Manufacture

4.1 The solvent cement shall be a solution of Class 12454-B, unplasticized poly(vinyl chloride) molding or extrusion compound as classified in Specification D 1784, or equivalent PVC resin.

4.2 Either virgin or clean rework material may be used, provided that the rework material is generated from the solvent cement manufacturer's own production, is compatible with virgin material, and will produce a cement that meets the requirements of this specification.

4.3 The cement shall be free-flowing and shall not contain lumps, macroscopic undissolved particles, or any foreign matter that will adversely affect the ultimate joint strength or chemical resistance of the cement.

4.4 The cement shall show no gelation. It shall show no

<sup>3</sup> Annual Book of ASTM Standards, Vol 08.04.

stratification or separation that cannot be removed by stirring or shaking.

4.5 Inert fillers may be added, provided the resulting cement meets all requirements of this specification.

4.6 The solvents used in the formulation of this solvent cement shall consist of tetrahydrofuran (THF) in combination with cyclohexanone or methyl ethyl ketone (MEK), or both.

NOTE 2—It is recommended that solvent cements made to this specification not be orange since that color is recommended for use with CPVC solvent cement under Specification F 493.

## 5. Other Requirements

5.1 *Resin Content*—The PVC resin content shall be 10 % minimum when tested in accordance with 6.1.

5.2 *Dissolution*—The cement shall be capable of dissolving an additional 3 weight % of Class 12454-B, PVC compound or the equivalent PVC resin at  $73.4 \pm 3.6^\circ\text{F}$  ( $23 \pm 2^\circ\text{C}$ ) without evidence of gelation.

5.3 *Viscosity*—The minimum viscosity at room temperature shall be 90 cP (90 mPa·s) when tested in accordance with 6.2.

NOTE 3—Cements approaching the minimum viscosity requirement of this specification generally are not recommended for noninterference-type fit (where a gap exists between the pipe and fitting socket).

5.4 *Lap Shear Strength*—The minimum average lap shear strength when tested in accordance with 6.3.2 shall be 600 psi (4.1 MPa) after a 72-h curing time.

5.5 *Hydrostatic Burst Strength*—The minimum average hydrostatic burst strength when tested in accordance with 6.3.3 shall be 200 psi (1.4 MPa) after a 72-h curing time.

## 6. Test Methods

### 6.1 Solids Content:

#### 6.1.1 Apparatus:

6.1.1.1 *Ointment Tins* (Style No. 12, 1-oz (30-mL), all metal).

6.1.1.2 *Vacuum Oven*.

6.1.1.3 *Analytical Balance*.

6.1.1.4 *Centrifuge*.

#### 6.1.2 Procedure:

6.1.2.1 Stir the sample thoroughly with a spatula before weighing (Note 4). Weigh  $3.0 \pm 0.5$  g of the sample to the nearest 1 mg into a tared ointment tin. Place the tin into the vacuum oven (Note 5), and heat at  $248^\circ\text{F}$  ( $120^\circ\text{C}$ ) for 45 min + 15, -0 min. Discard specimens left in for more than 1 h. The vacuum must be continually in operation to draw off flammable solvents. Absolute pressure should not exceed 15 mm Hg. Remove the tin from the oven and place in a desiccator until cooled to room temperature. Weigh the tin and dried sample to the nearest 1 mg.

NOTE 4—This material is usually nonhomogeneous and shall be thoroughly stirred before weighing. The weighing shall also be accomplished quickly to avoid loss of solvent by volatilization. Some vacuum ovens require a longer period of time than 15 min to reach  $120^\circ\text{C}$ , even after preheating. It is recommended that the operator watch closely the time required to reach  $120^\circ\text{C}$  and, by manipulation of the heat control mechanism, minimize the amount of time required to reach  $120^\circ\text{C}$  while not exceeding the required temperature.

NOTE 5—The use of a vacuum oven is mandatory for drying the specimen. This oven has neither an exposed heating surface nor an open

flame, thus avoiding the danger of flashing. The oven also provides an open vacuum to exhaust solvent fumes.

6.1.2.2 After weighing, dissolve the dried sample in THF and determine quantitatively any inert fillers by means of centrifuging. Deduct the weight of the fillers determined from the weight of the dried sample prior to calculating the content of PVC resin in the cement.

NOTE 6—Dissolve most of the dried sample by adding 15 mL of THF to the sample in the ointment tin and stirring with a glass rod for 15 min. Dissolve the remainder with a second addition of 15 mL of THF, followed by a third addition of 5 mL of THF to rinse the ointment tin. Centrifuge the entire volume at 20 000 r/min for 15 min. Discard the supernatant liquid. Add 15 mL of THF to the tube, mix thoroughly, and transfer the tube contents to the ointment tin. Use 2 mL more of THF to wash down the tube, and pour into the ointment tin. Evaporate off the THF in the vacuum oven at  $248^\circ\text{F}$  ( $120^\circ\text{C}$ ) for 45 min. Cool in desiccator, weigh the tin to the nearest 1 mg, and calculate the percent of inert filler present in the cement.

6.1.3 *Calculation*—Calculate the percentage of PVC resin, *R*, as follows:

$$R, \% = [(B - A - D)/(C - A)] \times 100$$

where:

*A* = weight of ointment tin,

*B* = weight of tin and specimen after drying,

*C* = weight of tin and specimen before drying, and

*D* = weight of inert filler, if present.

6.2 *Viscosity*—Measure the viscosity in accordance with Method B of Test Methods D 1084 except that conditioning to temperature equilibrium only is required. For qualification purposes use a Model RVF viscometer, a speed of 10 r/min, and the spindle that, by trial, gives the closest reading to center range of scale for the cement being tested. Other speeds may be used for quality control purposes.

### 6.3 Bond Strength:

6.3.1 *Number of Specimens*—A minimum of five specimens shall be tested for each requirement of 5.4 and 5.5.

#### 6.3.2 Lap Shear Strength:

6.3.2.1 Each test specimen (Fig. 1) shall consist of a 1 by 1-in. (25 by 25-mm) section cut from a 1/4-in. (6-mm) thick Type I rigid ABS sheet and a 1 by 2-in. (25 by 50-mm) section cut from a 1/4-in. (6-mm) thick Type I rigid PVC sheet.

6.3.2.2 Clean the surfaces to be adhered with a cloth dampened with methyl ethyl ketone (MEK).

6.3.2.3 Using a 1-in. (25-mm) natural bristle brush, apply a thin layer of cement to the complete surface of a 1 by 1-in. (25

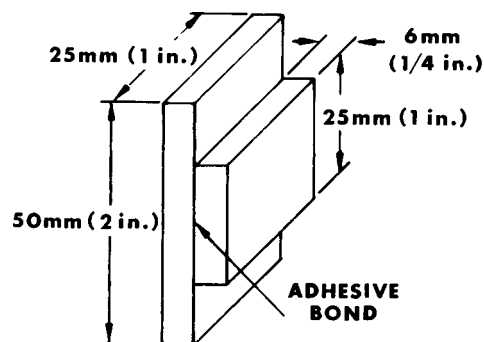

FIG. 1 Compressive Shear Specimen