

---

---

**Tool holders with rectangular shank for  
indexable inserts —**

**Part 6:  
Style G**

*Porte-plaquette à queue rectangulaire pour plaquettes amovibles —*

*Partie 6: Forme G*

**iTeh STANDARD PREVIEW  
(standards.iteh.ai)**

ISO 5610-6:2010

<https://standards.iteh.ai/catalog/standards/sist/83e4fd8a-90ce-4fce-b3a2-2f663cfa2893/iso-5610-6-2010>



**PDF disclaimer**

This PDF file may contain embedded typefaces. In accordance with Adobe's licensing policy, this file may be printed or viewed but shall not be edited unless the typefaces which are embedded are licensed to and installed on the computer performing the editing. In downloading this file, parties accept therein the responsibility of not infringing Adobe's licensing policy. The ISO Central Secretariat accepts no liability in this area.

Adobe is a trademark of Adobe Systems Incorporated.

Details of the software products used to create this PDF file can be found in the General Info relative to the file; the PDF-creation parameters were optimized for printing. Every care has been taken to ensure that the file is suitable for use by ISO member bodies. In the unlikely event that a problem relating to it is found, please inform the Central Secretariat at the address given below.

**iTeh STANDARD PREVIEW**  
**(standards.iteh.ai)**

[ISO 5610-6:2010](https://standards.iteh.ai/catalog/standards/sist/83e4fd8a-90ce-4fce-b3a2-2f663cfa2893/iso-5610-6-2010)

<https://standards.iteh.ai/catalog/standards/sist/83e4fd8a-90ce-4fce-b3a2-2f663cfa2893/iso-5610-6-2010>



**COPYRIGHT PROTECTED DOCUMENT**

© ISO 2010

All rights reserved. Unless otherwise specified, no part of this publication may be reproduced or utilized in any form or by any means, electronic or mechanical, including photocopying and microfilm, without permission in writing from either ISO at the address below or ISO's member body in the country of the requester.

ISO copyright office  
Case postale 56 • CH-1211 Geneva 20  
Tel. + 41 22 749 01 11  
Fax + 41 22 749 09 47  
E-mail [copyright@iso.org](mailto:copyright@iso.org)  
Web [www.iso.org](http://www.iso.org)

Published in Switzerland

## Foreword

ISO (the International Organization for Standardization) is a worldwide federation of national standards bodies (ISO member bodies). The work of preparing International Standards is normally carried out through ISO technical committees. Each member body interested in a subject for which a technical committee has been established has the right to be represented on that committee. International organizations, governmental and non-governmental, in liaison with ISO, also take part in the work. ISO collaborates closely with the International Electrotechnical Commission (IEC) on all matters of electrotechnical standardization.

International Standards are drafted in accordance with the rules given in the ISO/IEC Directives, Part 2.

The main task of technical committees is to prepare International Standards. Draft International Standards adopted by the technical committees are circulated to the member bodies for voting. Publication as an International Standard requires approval by at least 75 % of the member bodies casting a vote.

Attention is drawn to the possibility that some of the elements of this document may be the subject of patent rights. ISO shall not be held responsible for identifying any or all such patent rights.

ISO 5610-6 was prepared by Technical Committee ISO/TC 29, *Small tools*, Subcommittee SC 9, *Tools with cutting edges made of hard cutting materials*.

This first edition of ISO 5610-6, together with ISO 5610-1, ISO 5610-2, ISO 5610-3, ISO 5610-4, ISO 5610-5, ISO 5610-7, ISO 5610-8, ISO 5610-9, ISO 5610-10, ISO 5610-11, ISO 5610-12, ISO 5610-13, ISO 5610-14 and ISO 5610-15, cancels and replaces ISO 5610:1998.

ISO 5610 consists of the following parts, under the general title *Tool holders with rectangular shank for indexable inserts*:

- <https://standards.iteh.ai/catalog/standards/sist/83e4fd8a-90ce-4fce-b3a2-28627658272e/iso-5610-6:2010>
- Part 1: General survey, correlation and determination of dimensions
  - Part 2: Style A
  - Part 3: Style B
  - Part 4: Style D
  - Part 5: Style F
  - Part 6: Style G
  - Part 7: Style J
  - Part 8: Style K
  - Part 9: Style L
  - Part 10: Style N
  - Part 11: Style R
  - Part 12: Style S
  - Part 13: Style T
  - Part 14: Style H
  - Part 15: Style V

**iTeh STANDARD PREVIEW**  
**(standards.iteh.ai)**

ISO 5610-6:2010

<https://standards.iteh.ai/catalog/standards/sist/83e4fd8a-90ce-4fce-b3a2-2f663cfa2893/iso-5610-6-2010>

# Tool holders with rectangular shank for indexable inserts —

## Part 6: Style G

### 1 Scope

This part of ISO 5610 specifies tool holders with rectangular shank, style G, i.e. with offset shank and cutting edge angle  $\kappa_r = 90^\circ$  for side cutting.

These tool holders are primarily intended for indexable inserts made of hardmetal or other cutting materials to be mounted by clamping and to be used for turning operations.

NOTE The symbols for the dimensions shown in the tables of this part of ISO 5610 and the corresponding preferred symbols of properties defined in ISO/TS 13399-2 and ISO/TS 13399-3 are given in ISO 5610-1:2010, Table A.1.

iTeh STANDARD PREVIEW

### 2 Normative references (standards.iteh.ai)

The following referenced documents are indispensable for the application of this document. For dated references, only the edition cited applies. For undated references, the latest edition of the referenced document (including any amendments) applies.

ISO 5608:1995, *Turning and copying tool holders and cartridges for indexable inserts — Designation*

ISO 5610-1:2010, *Tool holders with rectangular shank for indexable inserts — Part 1: General survey, correlation and determination of dimensions*

### 3 Dimensions

#### 3.1 General

It is not necessary for tool holders to comply with the pictorial representation; only the dimensions given shall be observed.

For determination of dimensions  $h_1$ ,  $f$  and  $l_1$ , see ISO 5610-1.

For explanation of the designation code for tool holders, see ISO 5608.

NOTE The values of rake angles and inclination angles shown in the figures are recommended values; they can vary according to the application.

3.2 Tool holder style G for rhombic indexable insert shape C

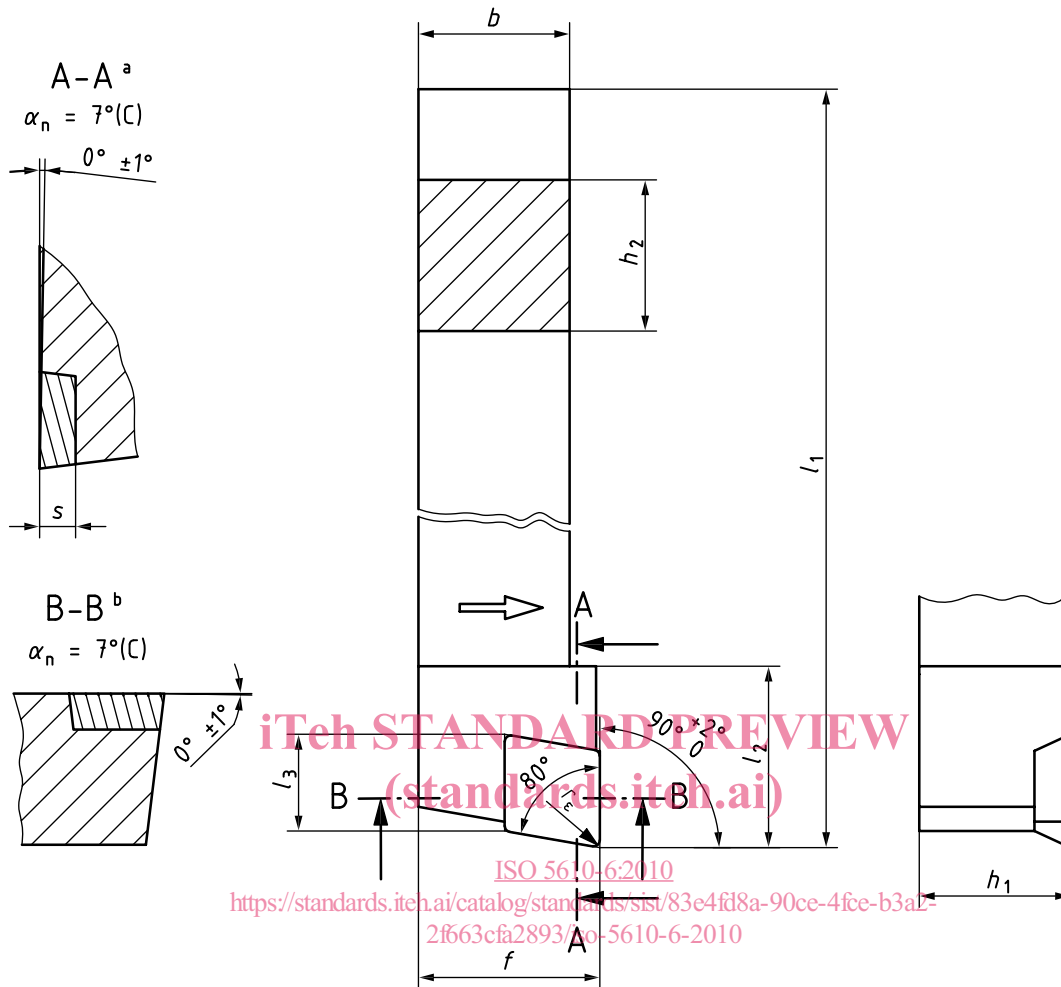

NOTE The figure shows a right-hand tool holder (R); left-hand tool holder (L) laterally reversed.

- a Inclination angle  $\lambda_n$ .
- b Rake angle  $\gamma_n$ .

Figure 1 — Tool holder style G for rhombic indexable insert — C

Table 1

Dimensions in millimetres

| Symbol <sup>a</sup> | $h_1$ | $b$ | $l_3$ | $f$   | $h_2$ | $l_1^a$ | $l_2$ | $s^b$ |
|---------------------|-------|-----|-------|---|-------|---------|-------|-------|
| SCGCR 0808 — 06     | js13  | h13 | ≈     | $\begin{smallmatrix} +0,5 \\ 0 \end{smallmatrix}$ | h13   | k16     | max.  |       |
| SCGCL 0808 — 06     | 8     | 8   | 6,4   | 10  | 8     | —       | 12    | 2,38  |
| SCGCR 1010 — 06     | 10    | 10  | 6,4   | 12  | 10    | —       | 12    | 2,38  |
| SCGCL 1010 — 06     |       |     |       |   |       |         |       |       |

<sup>a</sup> For the selection of length,  $l_1$ , the en-dash may be replaced by the dimensions of ISO 5610-1:2010, Table 2. For letter symbols identifying the tool length, see ISO 5608:1995, Table 6.

<sup>b</sup> Insert thickness without shim, if any.

3.3 Tool holder style G for triangular indexable insert shape T

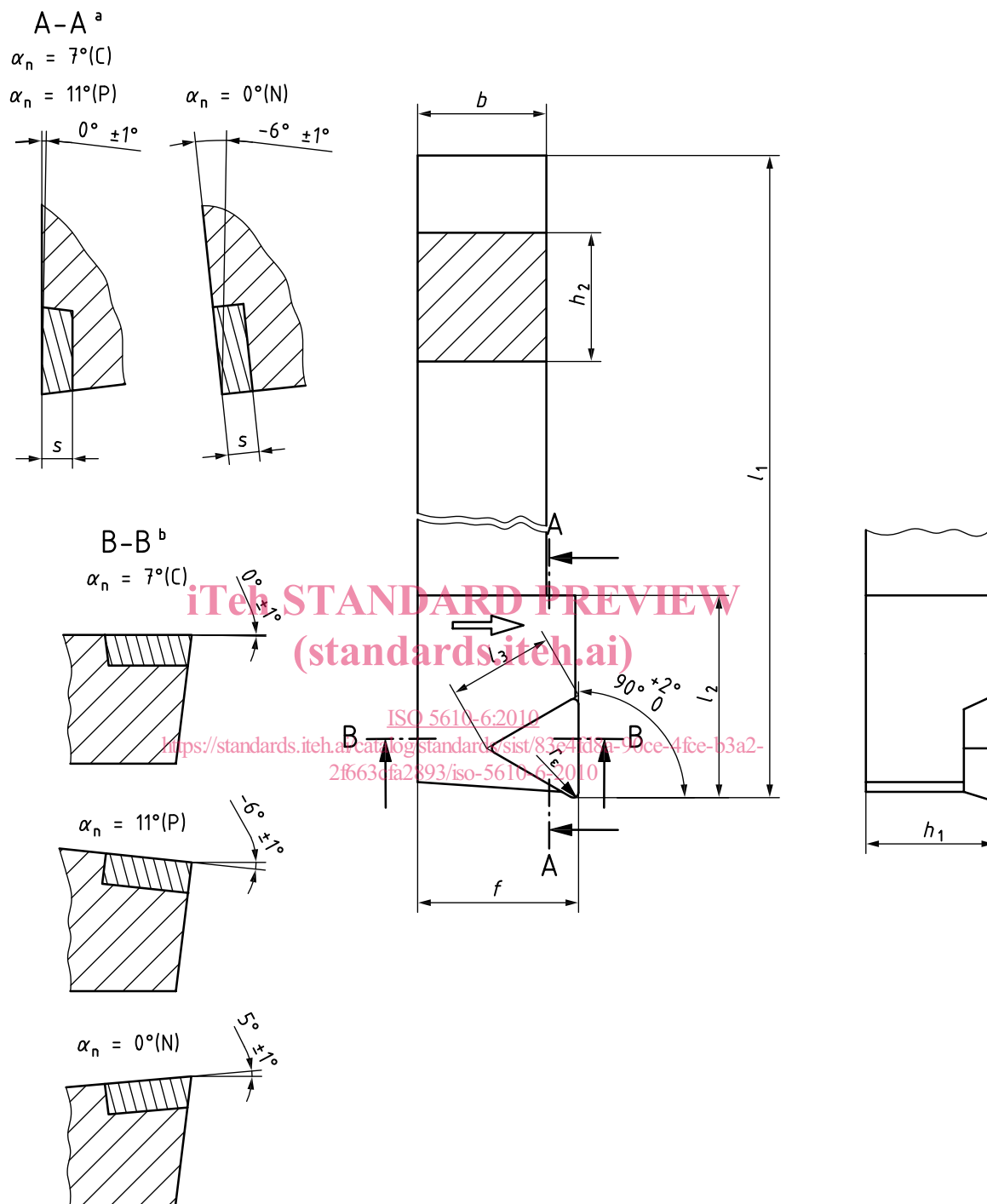

NOTE The figure shows a right-hand tool holder (R); left-hand tool holder (L) laterally reversed.

- a Inclination angle  $\lambda_n$ .
- b Rake angle  $\gamma_n$ .

Figure 2 — Tool holder style G for triangular indexable insert — T

Table 2

Dimensions in millimetres

| Symbol <sup>a</sup> | $h_1$ | $b$ | $l_3$ | $f$   | $h_2$ | $l_1^a$ | $l_2$ | $s^b$ |
|---------------------|-------|-----|-------|---|-------|---------|-------|-------|
|                     | js13  | h13 | ≈     | $\begin{smallmatrix} +0,5 \\ 0 \end{smallmatrix}$ | h13   | k16     | max.  |       |
| STGCR 1212 — 11     | 12    | 12  | 11    | 16  | 12    | —       | 25    | 2,38  |
| STGCL 1212 — 11     |       |     |       |   |       |         |       | 3,18  |
| PTGNR 1212 — 11     |       |     |       |   |       |         |       |       |
| PTGNL 1212 — 11     |       |     |       |   |       |         |       |       |
| CTGPR 1212 — 11     |       |     |       |   |       |         |       |       |
| CTGPL 1212 — 11     |       |     |       |   |       |         |       |       |
| STGCR 1616 — 11     | 16    | 16  | 11    | 20  | 16    | —       | 25    | 2,38  |
| STGCL 1616 — 11     |       |     |       |   |       |         |       | 3,18  |
| PTGNR 1616 — 11     |       |     |       |   |       |         |       |       |
| PTGNL 1616 — 11     |       |     |       |   |       |         |       |       |
| CTGPR 1616 — 11     |       |     |       |   |       |         |       |       |
| CTGPL 1616 — 11     |       |     |       |   |       |         |       |       |
| STGCR 1616 — 16     | 16    | 16  | 16,5  | 20  | 16    | —       | 32    | 3,97  |
| STGCL 1616 — 16     |       |     |       |   |       |         |       | 4,76  |
| PTGNR 1616 — 16     |       |     |       |   |       |         |       |       |
| PTGNL 1616 — 16     |       |     |       |   |       |         |       |       |
| CTGPR 1616 — 16     |       |     |       |   |       |         |       |       |
| CTGPL 1616 — 16     |       |     |       |   |       |         |       |       |
| STGCR 2020 — 16     | 20    | 20  | 16,5  | 25  | 20    | —       | 32    | 3,97  |
| STGCL 2020 — 16     |       |     |       |   |       |         |       | 4,76  |
| PTGNR 2020 — 16     |       |     |       |   |       |         |       |       |
| PTGNL 2020 — 16     |       |     |       |   |       |         |       |       |
| CTGPR 2020 — 16     |       |     |       |   |       |         |       |       |
| CTGPL 2020 — 16     |       |     |       |   |       |         |       |       |
| STGCR 2525 — 16     | 25    | 25  | 16,5  | 32  | 25    | —       | 32    | 3,97  |
| STGCL 2525 — 16     |       |     |       |   |       |         |       | 4,76  |
| PTGNR 2525 — 16     |       |     |       |   |       |         |       |       |
| PTGNL 2525 — 16     |       |     |       |   |       |         |       |       |
| CTGPR 2525 — 16     |       |     |       |   |       |         |       |       |
| CTGPL 2525 — 16     |       |     |       |   |       |         |       |       |
| STGCR 2525 — 22     | 25    | 25  | 22    | 32  | 25    | —       | 36    | 4,76  |
| STGCL 2525 — 22     |       |     |       |   |       |         |       |       |
| PTGNR 2525 — 22     |       |     |       |   |       |         |       |       |
| PTGNL 2525 — 22     |       |     |       |   |       |         |       |       |
| CTGPR 2525 — 22     |       |     |       |   |       |         |       |       |
| CTGPL 2525 — 22     |       |     |       |   |       |         |       |       |

iTeh STANDARD PREVIEW  
(standards.itech.ai)

ISO 5610-6:2010

<https://standards.itech.ai/catalog/standards/sist/83e4fd8a-90ce-4fce-b3a2-2f663cfa2893/iso-5610-6-2010>



Table 2 (continued)

Dimensions in millimetres

| Symbol <sup>a</sup> | $h_1$ | $b$ | $l_3$ | $f$   | $h_2$ | $l_1^a$ | $l_2$ | $s^b$ |
|---------------------|-------|-----|-------|---|-------|---------|-------|-------|
|                     | js13  | h13 | ≈     | $\begin{smallmatrix} +0,5 \\ 0 \end{smallmatrix}$ | h13   | k16     | max.  |       |
| STGCR 3225 — 16     | 32    | 25  | 16,5  | 32  | 32    | —       | 32    | 3,97  |
| STGCL 3225 — 16     |       |     |       |   |       |         |       | 4,76  |
| PTGNR 3225 — 16     |       |     |       |   |       |         |       |       |
| PTGNL 3225 — 16     |       |     |       |   |       |         |       |       |
| CTGPR 3225 — 16     |       |     |       |   |       |         |       |       |
| CTGPL 3225 — 16     |       |     |       |   |       |         |       | 3,18  |
| STGCR 3225 — 22     | 32    | 25  | 22    | 32  | 32    | —       | 36    | 4,76  |
| STGCL 3225 — 22     |       |     |       |   |       |         |       |       |
| PTGNR 3225 — 22     |       |     |       |   |       |         |       |       |
| PTGNL 3225 — 22     |       |     |       |   |       |         |       |       |
| CTGPR 3225 — 22     |       |     |       |   |       |         |       |       |
| CTGPL 3225 — 22     |       |     |       |   |       |         |       |       |
| STGCR 3232 — 22     | 32    | 32  | 22    | 40  | 32    | —       | 36    | 4,76  |
| STGCL 3232 — 22     |       |     |       |   |       |         |       |       |
| PTGNR 3232 — 22     |       |     |       |   |       |         |       |       |
| PTGNL 3232 — 22     |       |     |       |   |       |         |       |       |
| CTGPR 3232 — 22     |       |     |       |   |       |         |       |       |
| CTGPL 3232 — 22     |       |     |       |   |       |         |       |       |
| STGCR 4040 — 22     | 40    | 40  | 22    | 50  | 40    | —       | 36    | 4,76  |
| STGCL 4040 — 22     |       |     |       |   |       |         |       |       |
| PTGNR 4040 — 22     |       |     |       |   |       |         |       |       |
| PTGNL 4040 — 22     |       |     |       |   |       |         |       |       |
| CTGPR 4040 — 22     |       |     |       |   |       |         |       |       |
| CTGPL 4040 — 22     |       |     |       |   |       |         |       |       |
| PTGNR 4040 — 27     | 40    | 40  | 27,5  | 50  | 40    | —       | 40    | 6,35  |
| PTGNL 4040 — 27     |       |     |       |   |       |         |       |       |
| PTGNR 5050 — 27     | 50    | 50  | 27,5  | 60  | 50    | —       | 40    | 6,35  |
| PTGNL 5050 — 27     |       |     |       |   |       |         |       |       |

<sup>a</sup> See Table 1.

<sup>b</sup> See Table 1.