**Vitreous and porcelain enamels —
Determination of the edge covering on
enamelled steel plate to be used in heat
exchangers**

*Émaux vitrifiés — Détermination du revêtement de l'arête sur une
plaque en acier émaillé destinée aux échangeurs de chaleur*

iTeh STANDARD PREVIEW
(standards.iteh.ai)

[ISO 28723:2008](https://standards.iteh.ai/catalog/standards/sist/d2b5ac32-325b-4a32-88b0-f5b7de6afa40/iso-28723-2008)

[https://standards.iteh.ai/catalog/standards/sist/d2b5ac32-325b-4a32-88b0-
f5b7de6afa40/iso-28723-2008](https://standards.iteh.ai/catalog/standards/sist/d2b5ac32-325b-4a32-88b0-f5b7de6afa40/iso-28723-2008)



PDF disclaimer

This PDF file may contain embedded typefaces. In accordance with Adobe's licensing policy, this file may be printed or viewed but shall not be edited unless the typefaces which are embedded are licensed to and installed on the computer performing the editing. In downloading this file, parties accept therein the responsibility of not infringing Adobe's licensing policy. The ISO Central Secretariat accepts no liability in this area.

Adobe is a trademark of Adobe Systems Incorporated.

Details of the software products used to create this PDF file can be found in the General Info relative to the file; the PDF-creation parameters were optimized for printing. Every care has been taken to ensure that the file is suitable for use by ISO member bodies. In the unlikely event that a problem relating to it is found, please inform the Central Secretariat at the address given below.

iTeh STANDARD PREVIEW
(standards.iteh.ai)

ISO 28723:2008

<https://standards.iteh.ai/catalog/standards/sist/d2b5ac32-325b-4a32-88b0-f5b7de6afa40/iso-28723-2008>



COPYRIGHT PROTECTED DOCUMENT

© ISO 2008

All rights reserved. Unless otherwise specified, no part of this publication may be reproduced or utilized in any form or by any means, electronic or mechanical, including photocopying and microfilm, without permission in writing from either ISO at the address below or ISO's member body in the country of the requester.

ISO copyright office
Case postale 56 • CH-1211 Geneva 20
Tel. + 41 22 749 01 11
Fax + 41 22 749 09 47
E-mail copyright@iso.org
Web www.iso.org

Published in Switzerland

Contents

Page

| | |
|---|----|
| Foreword | iv |
| 1 Scope | 1 |
| 2 Normative references | 1 |
| 3 Principle..... | 1 |
| 4 Reagents and materials | 1 |
| 5 Apparatus | 2 |
| 6 Test specimens..... | 3 |
| 7 Procedure | 4 |
| 8 Calculation and expression of results | 4 |
| 9 Precision..... | 5 |
| 10 Test report..... | 5 |

iTeh STANDARD PREVIEW
(standards.iteh.ai)

[ISO 28723:2008](https://standards.iteh.ai/catalog/standards/sist/d2b5ac32-325b-4a32-88b0-f5b7de6afa40/iso-28723-2008)

<https://standards.iteh.ai/catalog/standards/sist/d2b5ac32-325b-4a32-88b0-f5b7de6afa40/iso-28723-2008>

Foreword

ISO (the International Organization for Standardization) is a worldwide federation of national standards bodies (ISO member bodies). The work of preparing International Standards is normally carried out through ISO technical committees. Each member body interested in a subject for which a technical committee has been established has the right to be represented on that committee. International organizations, governmental and non-governmental, in liaison with ISO, also take part in the work. ISO collaborates closely with the International Electrotechnical Commission (IEC) on all matters of electrotechnical standardization.

International Standards are drafted in accordance with the rules given in the ISO/IEC Directives, Part 2.

The main task of technical committees is to prepare International Standards. Draft International Standards adopted by the technical committees are circulated to the member bodies for voting. Publication as an International Standard requires approval by at least 75 % of the member bodies casting a vote.

Attention is drawn to the possibility that some of the elements of this document may be the subject of patent rights. ISO shall not be held responsible for identifying any or all such patent rights.

ISO 28723 was prepared by the European Committee for Standardization (CEN) (as EN 14863) and was adopted, under a special “fast-track procedure”, by Technical Committee ISO/TC 107, *Metallic and other inorganic coatings*, in parallel with its approval by the ISO member bodies.

ITEH STANDARD PREVIEW
(standards.iteh.ai)

[ISO 28723:2008](https://standards.iteh.ai/catalog/standards/sist/d2b5ac32-325b-4a32-88b0-f5b7de6afa40/iso-28723-2008)

<https://standards.iteh.ai/catalog/standards/sist/d2b5ac32-325b-4a32-88b0-f5b7de6afa40/iso-28723-2008>

Vitreous and porcelain enamels — Determination of the edge covering on enamelled steel plate to be used in heat exchangers

1 Scope

This International Standard specifies a test method for the determination of the covering of the edge of enamelled steel plate to be used in heat exchangers. This method is applicable to all enamelling processes.

It is applicable to plates with a thickness between 0,5 mm and 1,5 mm.

This method is not applicable where the current flow generated in the test exceeds 3 A.

2 Normative references

The following referenced documents are indispensable for the application of this document. For dated references, only the edition cited applies. For undated references, the latest edition of the referenced document (including any amendments) applies.

ISO 3696, *Water for analytical laboratory use — Specification and test methods*

[https://standards.iteh.ai/catalog/standards/sist/d2b5ac32-325b-4a32-88b0-](https://standards.iteh.ai/catalog/standards/sist/d2b5ac32-325b-4a32-88b0-757316c840f6/iso-38723-2008)

EN 10088-1, *Stainless steels — List of stainless steels*

3 Principle

The edge of an enamelled steel plate to be tested is submerged in an electrolyte. An alternating current source and a stabilized voltage are connected to the plate. The recorded current is a measure of the covering at the edge.

4 Reagents and materials

During the analysis, unless otherwise stated, use only reagents of recognized analytical grade and distilled or de-mineralized water or water of equivalent purity.

4.1 Pickling fluid, consisting of sulfuric acid (H_2SO_4) solution, $(7 \pm 0,5)$ % by mass, with an Fe^{2+} concentration of $(2 \pm 1,5)$ g/l, at a temperature of (60 ± 2) °C.

4.2 Test bath electrolyte, consisting of sodium chloride solution, 5 % NaCl by mass, made with distilled water conforming to grade 3 of ISO 3696, at a temperature of (22 ± 3) °C.

5 Apparatus

5.1 Test bath, consisting of a polypropylene container holding the electrolyte solution in which the electrodes and a test plate are placed. Polypropylene plates are used for centring and holding the test plate 10 mm from the bottom of the bath.

The arrangement of the bath and the dimensions of the components are shown in Figures 1, 2 and 3.

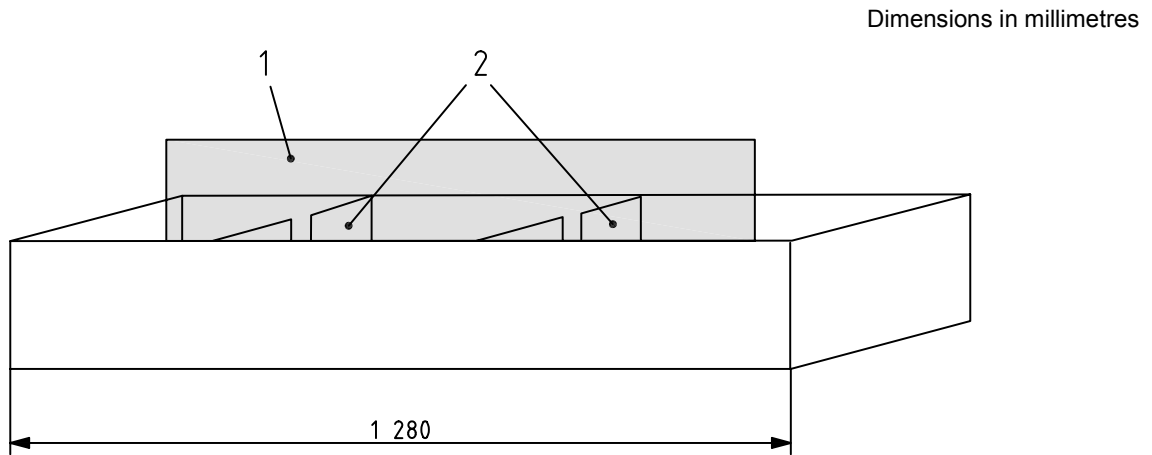

Key

- 1 plate to be tested
- 2 plates for centring and lifting the test plate from the bottom

iTeh STANDARD PREVIEW
(standards.iteh.ai)

Figure 1 — Dimensions of the test bath

<https://standards.iteh.ai/catalog/standards/sist/d2b5ac32-325b-4a32-88b0-f5b7de6afa40/iso-28723-2008>

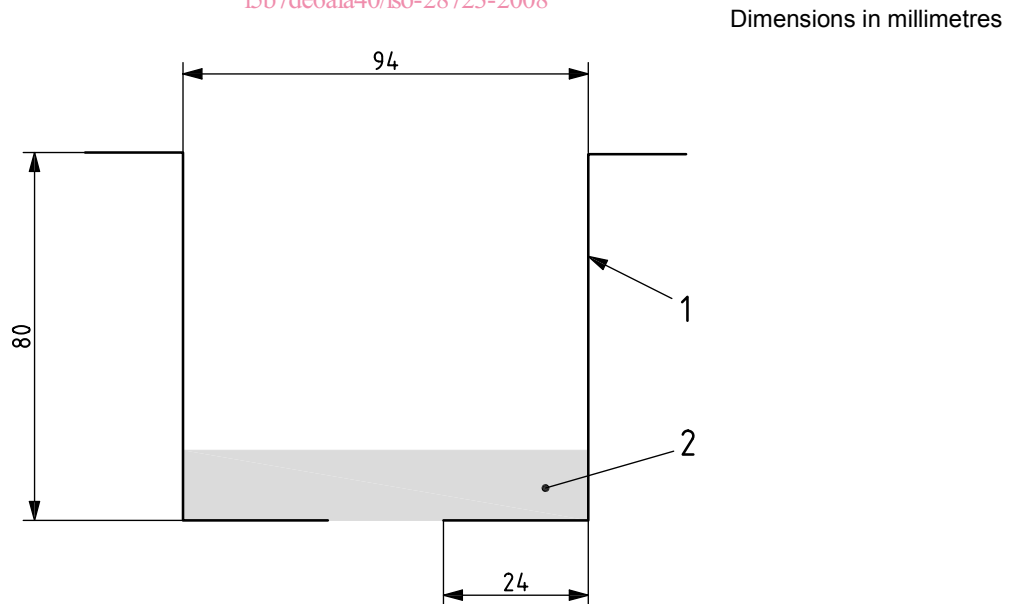

Key

- 1 electrode (1 264 mm long)
- 2 NaCl solution

Figure 2 — Dimensions of the two stainless-steel electrodes (EN 10088-1 grade 1.4301)

Dimensions in millimetres

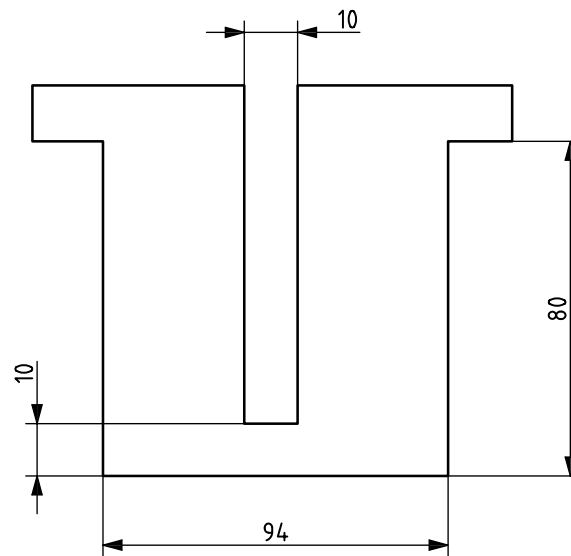

Figure 3 — Dimensions of the two polypropylene centring plates

5.2 Voltage source, consisting of a stabilized alternating source of $(10,0 \pm 0,05)$ V. The electrical diagram is shown in Figure 4.

The voltage source shall be able to maintain these voltage limits throughout the test.

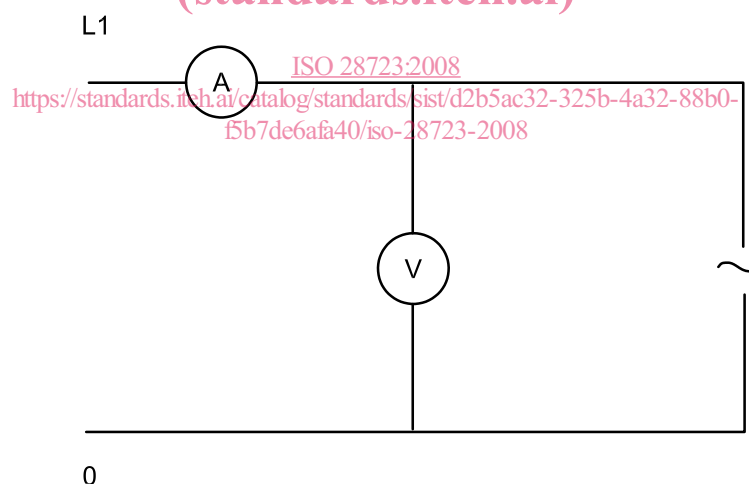

Figure 4 — Electrical diagram

5.3 Ammeter, capable of reading to the nearest 0,01 A.

6 Test specimens

Select at least one pair of plates, one corrugated and one undulated, of the same length. The minimum length of the edge to be used for the test is 300 mm.

Immerse the plates in the pickling solution (4.1) in a suitable container for a period of $10 \text{ min} \pm 10 \text{ s}$. Rinse the plates well with water and dry them.

7 Procedure

Using the design drawing, determine, to the nearest 1 mm, the total (i.e. stretched) length of the edge of the corrugated or undulated test specimen.

NOTE The stretched edge length is the length taking into account the profiling of the corrugation and undulation of the test specimen.

Determine the un-enamelled thickness of the test specimen to the nearest 0,1 mm.

Position the plate in the bath (5.1) in such a way that a maximum of 10 mm of the edge to be measured (one of the edges in the flue gas direction) is immersed in the electrolyte solution (4.2). Do this within one hour after rinsing off the sulfuric acid.

Connect the voltage source (5.2) between the bath electrodes and electrode L1 to the test specimen and, using the ammeter (5.3), record the current automatically ($3 \pm 0,5$) s after switching on the test voltage.

Repeat the test for the other edge of the test specimen and for the second test specimen.

8 Calculation and expression of results

For each edge, calculate the uncoated surface area, a , in mm^2 , using the equation:

$$a = 1,222I^2 + 12,903I \quad \text{iTeh STANDARD PREVIEW} \quad (1)$$

where I is the measured current, in A. **(standards.iteh.ai)**

Calculate the percentage free surface area, S , using the equation:

$$S = \frac{a}{b \times c} 100 \quad \text{ISO 28723:2008} \quad (2)$$

<https://standards.iteh.ai/catalog/standards/sist/d2b5ac32-325b-4a32-88b0-f5b7de6afa40/iso-28723-2008>

where

a is the uncoated surface area, in mm^2 , calculated from Equation (1);

b is the stretched length of the edge of the plate, in mm;

c is the thickness of the un-enamelled plate, in mm.

Calculate the percentage edge covering, E , using the equation:

$$E = 100 - S \quad (3)$$

Express the percentage edge covering as the mean of all the determinations, rounded to the nearest 0,1 %.

Calculate the uncoated surface area, U , in mm^2/m , using the equation:

$$U = \frac{a}{b} 1000 \quad (4)$$

Express the uncoated surface area per metre length as the mean of all the determinations, rounded to the nearest $10 \text{ mm}^2/\text{m}$.

9 Precision

The precision of this measurement is $\pm 0,3$ % of the calculated percentage edge covering and ± 2 mm²/m of the uncoated surface area.

10 Test report

The test report shall include the following information:

- a) all information necessary for the identification of the sample tested;
- b) a reference to this International Standard, i.e. ISO 28723:2008;
- c) the results of the test, calculated as described in Clause 8, expressed as:
 - the mean percentage edge covering, rounded to the nearest 0,1 %,
 - the mean uncoated surface area per metre length, rounded to the nearest 10 mm²/m,and including the results of the individual determinations and the thickness of the un-enamelled plate.
- d) any deviations from the procedure specified;
- e) any unusual features (anomalies) observed during the test;
- f) the date of the test.

ITh STANDARD PREVIEW
(standards.iteh.ai)
<https://standards.iteh.ai/catalog/standards/sist/d2b5ac32-325b-4a32-88b0-f5b7de6afa40/iso-28723-2008>