**Tools for pressing — Ball-lock
punches —**

**Part 1:
Ball-lock punches for light duty**

Outillage de presse — Poinçons à bille —

Partie 1: Poinçons à bille pour tôles minces
iTeh STANDARD PREVIEW
(standards.iteh.ai)

ISO 10071-1:2008

<https://standards.iteh.ai/catalog/standards/sist/a4ed745f-57e0-4dfb-90ed-186171be7379/iso-10071-1-2008>



PDF disclaimer

This PDF file may contain embedded typefaces. In accordance with Adobe's licensing policy, this file may be printed or viewed but shall not be edited unless the typefaces which are embedded are licensed to and installed on the computer performing the editing. In downloading this file, parties accept therein the responsibility of not infringing Adobe's licensing policy. The ISO Central Secretariat accepts no liability in this area.

Adobe is a trademark of Adobe Systems Incorporated.

Details of the software products used to create this PDF file can be found in the General Info relative to the file; the PDF-creation parameters were optimized for printing. Every care has been taken to ensure that the file is suitable for use by ISO member bodies. In the unlikely event that a problem relating to it is found, please inform the Central Secretariat at the address given below.

iTeh STANDARD PREVIEW
(standards.iteh.ai)

[ISO 10071-1:2008](https://standards.iteh.ai/catalog/standards/sist/a4ed745f-57e0-4dfb-90ed-186171be7379/iso-10071-1-2008)

<https://standards.iteh.ai/catalog/standards/sist/a4ed745f-57e0-4dfb-90ed-186171be7379/iso-10071-1-2008>



COPYRIGHT PROTECTED DOCUMENT

© ISO 2008

All rights reserved. Unless otherwise specified, no part of this publication may be reproduced or utilized in any form or by any means, electronic or mechanical, including photocopying and microfilm, without permission in writing from either ISO at the address below or ISO's member body in the country of the requester.

ISO copyright office
Case postale 56 • CH-1211 Geneva 20
Tel. + 41 22 749 01 11
Fax + 41 22 749 09 47
E-mail copyright@iso.org
Web www.iso.org

Published in Switzerland

Contents

Page

Foreword.....	iv
1 Scope	1
2 Normative references	1
3 Terms and definitions	1
4 Dimensions	1
4.1 Basic dimensions — Ball in locking position	1
4.2 Perforating punches	3
4.3 Pilot punches	6
4.4 Punches with ejector	8
5 Material and hardness	11
6 Designation	11
Bibliography	12

iTeh STANDARD PREVIEW
(standards.iteh.ai)

[ISO 10071-1:2008](https://standards.iteh.ai/catalog/standards/sist/a4ed745f-57e0-4dfb-90ed-186171be7379/iso-10071-1-2008)

<https://standards.iteh.ai/catalog/standards/sist/a4ed745f-57e0-4dfb-90ed-186171be7379/iso-10071-1-2008>

Foreword

ISO (the International Organization for Standardization) is a worldwide federation of national standards bodies (ISO member bodies). The work of preparing International Standards is normally carried out through ISO technical committees. Each member body interested in a subject for which a technical committee has been established has the right to be represented on that committee. International organizations, governmental and non-governmental, in liaison with ISO, also take part in the work. ISO collaborates closely with the International Electrotechnical Commission (IEC) on all matters of electrotechnical standardization.

International Standards are drafted in accordance with the rules given in the ISO/IEC Directives, Part 2.

The main task of technical committees is to prepare International Standards. Draft International Standards adopted by the technical committees are circulated to the member bodies for voting. Publication as an International Standard requires approval by at least 75 % of the member bodies casting a vote.

Attention is drawn to the possibility that some of the elements of this document may be the subject of patent rights. ISO shall not be held responsible for identifying any or all such patent rights.

ISO 10071-1 was prepared by Technical Committee ISO/TC 29, *Small tools*, Subcommittee SC 8, *Tools for pressing and moulding*.

This second edition cancels and replaces the first edition (ISO 10071-1:2001), of which it constitutes a minor revision. In particular, the normative references given in Clause 2 have been updated, and the indication of surface textures has been made in accordance with ISO 1302:2002.

ISO 10071 consists of the following parts, under the general title *Tools for pressing — Ball-lock punches*:

- *Part 1: Ball-lock punches for light duty*
- *Part 2: Ball-lock punches for heavy duty*

Tools for pressing — Ball-lock punches —

Part 1: Ball-lock punches for light duty

1 Scope

This part of ISO 10071 specifies interchangeability dimensions and tolerances, in millimetres, for ball-lock punches for light duty.

It is applicable to ball-lock punches with shank diameter sizes from 6 mm up to and including 32 mm, in round, square, rectangular and oblong shapes, for punching holes in steel sheets or other materials, the thickness of which is less than 3 mm.

This part of ISO 10071 also gives examples related to materials and hardness, and specifies the designation of ball-lock punches for light duty.

2 Normative references

The following referenced documents are indispensable for the application of this document. For dated references, only the edition cited applies. For undated references, the latest edition of the referenced document (including any amendments) applies.

ISO 2768-1:1989, *General tolerances — Part 1: Tolerances for linear and angular dimensions without individual tolerance indications*

ISO 8695, *Tools for pressing — Punches — Nomenclature and terminology*

3 Terms and definitions

For the purposes of this part of ISO 10071, the terms and definitions given in ISO 8695 apply.

4 Dimensions

4.1 Basic dimensions — Ball in locking position

The dimension of the ball and the dimensions and tolerances of the ball seat of ball-lock punches for light duty shall conform to the indications given in Figure 1 and Table 1.

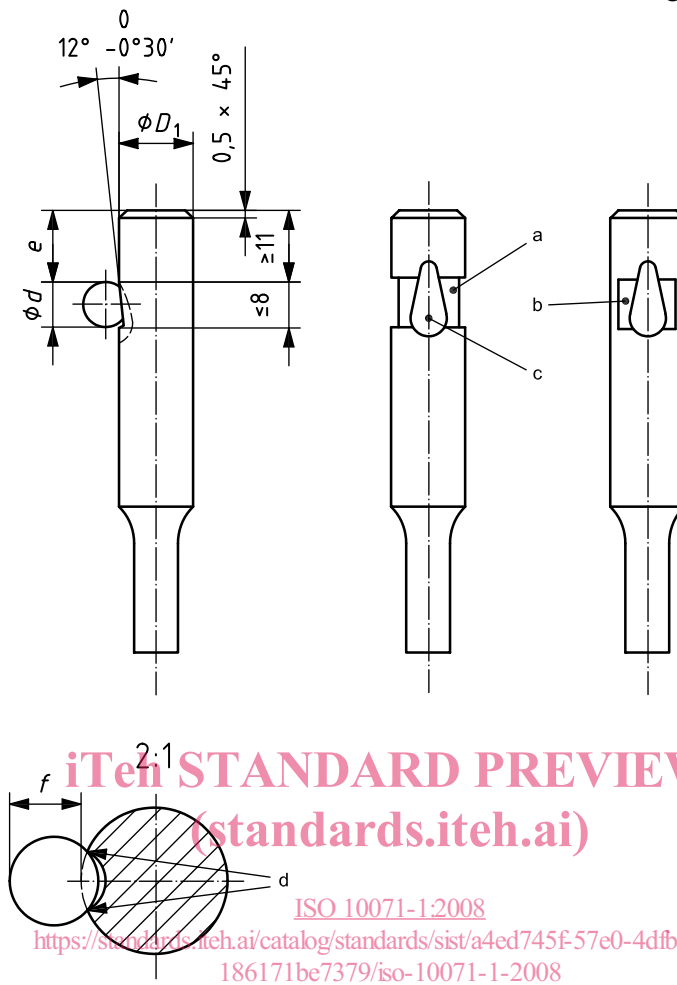

- a Ball seat relief: type and dimensions at manufacturer's direction.
- b Alternative ball seat relief types (band type, swipe type).
- c Ball seat.
- d Two-point contact.

Figure 1

Table 1

D_1	Ball diameter	e	f
g5	d	$\begin{matrix} +0,2 \\ 0 \end{matrix}$	$\begin{matrix} 0 \\ -0,1 \end{matrix}$
6	6	14	5,2
10	8	12,4	6,7
13	8	12,4	6,7
16	8	12,4	6,7
20	8	12,4	6,7
25	8	12,4	6,7
32	8	12,4	6,7

4.2 Perforating punches

4.2.1 Punches with straight shank — Type A

The dimensions of type A ball-lock punches with a straight shank shall conform to the indications given in Figure 2 and Table 2.

General tolerance: ISO 2768-m
Surface roughness value in micrometres

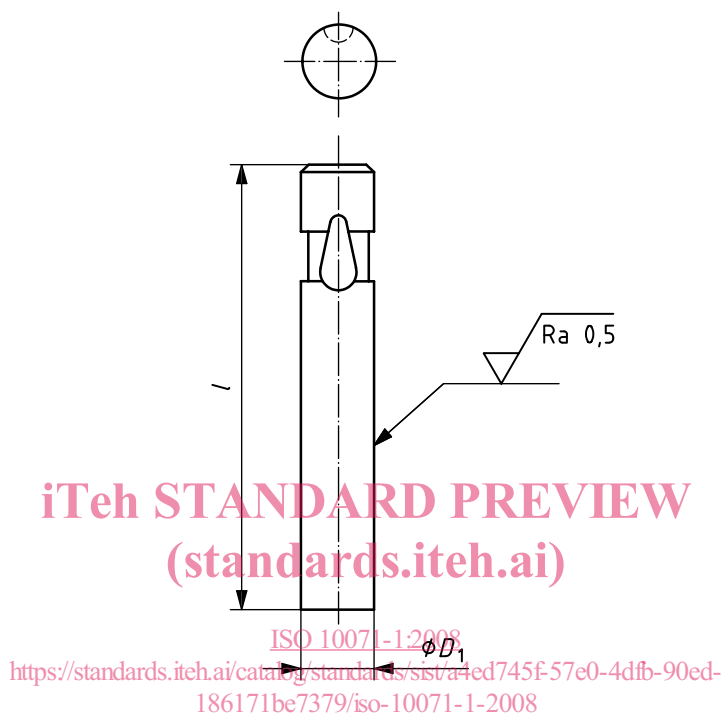

Figure 2

Table 2

D_1 g5	l +0,5 0				
	63	71	80	90	100
6	x	x	x	x	x
10	x	x	x	x	x
13	x	x	x	x	x
16		x	x	x	x
20		x	x	x	x
25		x	x	x	x
32		x	x	x	x

NOTE See 4.1 for the dimension of the ball and dimensions and tolerances of the ball seat.

4.2.2 Punches with reduced shank

4.2.2.1 Punches with round shape — Type B

The dimensions of type B ball-lock punches with a round shape shall conform to the indications given in Figure 3 and Table 3.

General tolerance: ISO 2768-m
Surface roughness value in micrometres

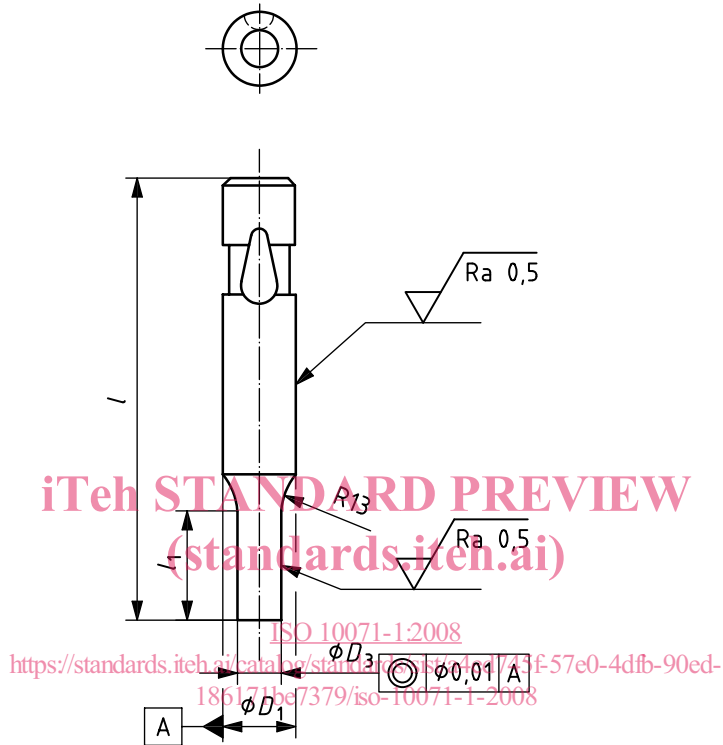

Figure 3

Table 3

D_1 g5	D_3 $\pm 0,01$	l $\begin{matrix} +0,5 \\ 0 \end{matrix}$				
		63	71	80	90	100
6	$1,6 \leq D_3 \leq 5,9$	x	x	x	x	x
10	$3,5 \leq D_3 \leq 9,9$	x	x	x	x	x
13	$6 \leq D_3 \leq 12,9$	x	x	x	x	x
16	$8,5 \leq D_3 \leq 15,9$		x	x	x	x
20	$12,5 \leq D_3 \leq 19,9$		x	x	x	x
25	$18 \leq D_3 \leq 24,9$		x	x	x	x
32	$20 \leq D_3 \leq 31,9$		x	x	x	x

NOTE The point length, l_1 , is left to the manufacturer's direction. See 4.1 for the dimension of the ball and dimensions and tolerances of the ball seat.

4.2.2.2 Punches with square (S), rectangular (R) and oblong (O) shapes — Types BS, BR and BO

The dimensions of types BS, BR and BO ball-lock punches with a square, rectangular and oblong shape shall conform to the indications given in Figure 4 and Table 4.

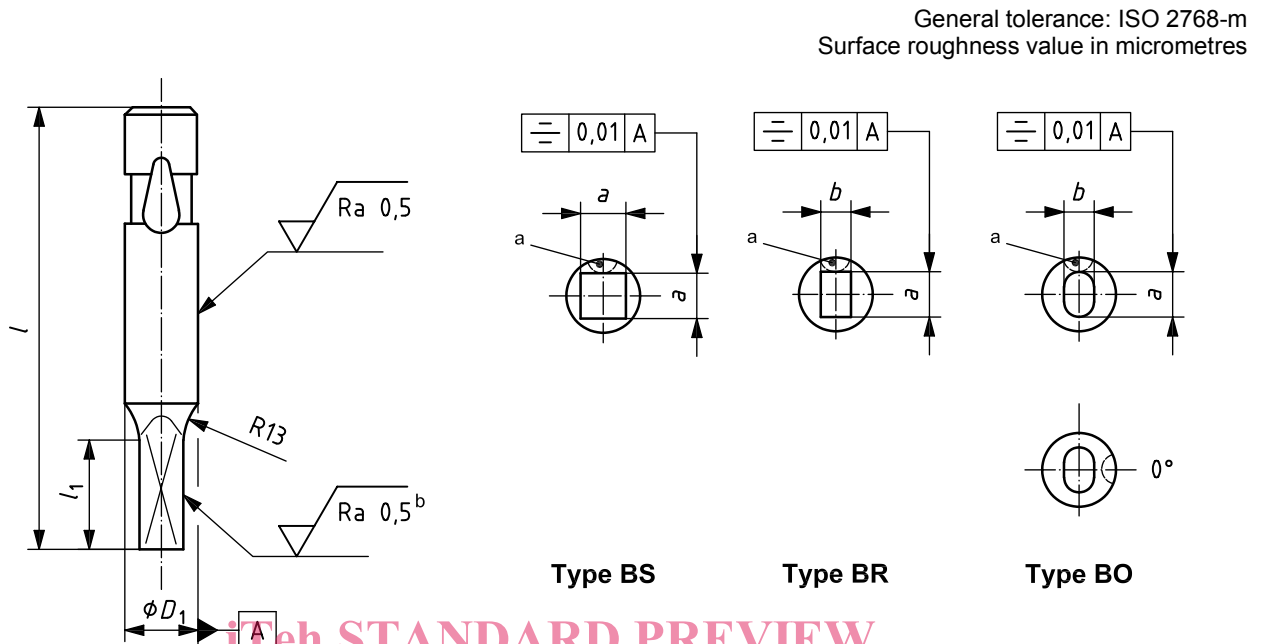

- a Standard at 90°.
- b On all work faces of the point.

<https://standards.iteh.ai/catalog/standards/iso-10071-1-2008>
 Figure 4
<https://standards.iteh.ai/catalog/standards/iso-10071-1-2008>

Table 4

D_1 g5	Type BS	Types BR and BO	l				
	a $\pm 0,01$	a and b $\pm 0,01$	+0,5	0	80	90	100
6	$1,6 \leq a \leq 4,2$	$1,6 \leq a$ and $b \leq 5,9$	63	71	80	90	100
10	$3,2 \leq a \leq 7$	$3,2 \leq a$ and $b \leq 9,9$	x	x	x	x	x
13	$5 \leq a \leq 9,1$	$5 \leq a$ and $b \leq 12,9$	x	x	x	x	x
16	$6,5 \leq a \leq 11,2$	$6,3 \leq a$ and $b \leq 15,9$	x	x	x	x	x
20	$8,5 \leq a \leq 14,1$	$8 \leq a$ and $b \leq 19,9$		x	x	x	x
25	$11 \leq a \leq 17,6$	$10 \leq a$ and $b \leq 24,9$		x	x	x	x
32	$14 \leq a \leq 22,5$	$12 \leq a$ and $b \leq 31,9$		x	x	x	x

NOTE The point length, l_1 , is left to the manufacturer's discretion. See 4.1 for the dimension of the ball and dimensions and tolerances of the ball seat.