



Designation: C1341 – 06

# Standard Test Method for Flexural Properties of Continuous Fiber-Reinforced Advanced Ceramic Composites<sup>1</sup>

This standard is issued under the fixed designation C1341; the number immediately following the designation indicates the year of original adoption or, in the case of revision, the year of last revision. A number in parentheses indicates the year of last reapproval. A superscript epsilon ( $\epsilon$ ) indicates an editorial change since the last revision or reapproval.

## 1. Scope

1.1 This test method covers the determination of flexural properties of continuous fiber-reinforced ceramic composites in the form of rectangular bars formed directly or cut from sheets, plates, or molded shapes. Three test geometries are described as follows:

1.1.1 *Test Geometry I*—A three-point loading system utilizing center point force application on a simply supported beam.

1.1.2 *Test Geometry IIA*—A four-point loading system utilizing two force application points equally spaced from their adjacent support points with a distance between force application points of one half of the support span.

1.1.3 *Test Geometry IIB*—A four-point loading system utilizing two force application points equally spaced from their adjacent support points with a distance between force application points of one third of the support span.

1.2 This test method applies primarily to all advanced ceramic matrix composites with continuous fiber reinforcement: uni-directional (1-D), bi-directional (2-D), tri-directional (3-D), and other continuous fiber architectures. In addition, this test method may also be used with glass (amorphous) matrix composites with continuous fiber reinforcement. However, flexural strength cannot be determined for those materials that do not break or fail by tension or compression in the outer fibers. This test method does not directly address discontinuous fiber-reinforced, whisker-reinforced, or particulate-reinforced ceramics. Those types of ceramic matrix composites are better tested in flexure using Test Methods C1161 and C1211.

1.3 Tests can be performed at ambient temperatures or at elevated temperatures. At elevated temperatures, a suitable furnace is necessary for heating and holding the test specimens at the desired testing temperatures.

1.4 This test method includes the following:

Scope	Section
	1

<sup>1</sup> This test method is under the jurisdiction of ASTM Committee C28 on Advanced Ceramics and is the direct responsibility of Subcommittee C28.07 on Ceramic Matrix Composites.

Current edition approved Jan. 1, 2006. Published January 2006. Originally approved in 1996. Last previous edition approved in 2005 as C1341 – 00 (2005). DOI: 10.1520/C1341-06.

Referenced Documents	2
Terminology	3
Summary of Test Method	4
Significance and Use	5
Interferences	6
Apparatus	7
Precautionary Statement	8
Test specimens	9
Procedures	10
Calculation of Results	11
Report	12
Precision and Bias	13
Keywords	14
References	
CFCC Surface Condition and Finishing	Annex A1
Conditions and Issues in Hot Loading of Test specimens into Furnaces	Annex A2
Toe Compensation on Stress-Strain Curves	Annex A3
Corrections for Thermal Expansion in Flexural Equations	Annex A4
Example of Test Report	Appendix X1

1.5 The values stated in SI units are to be regarded as the standard in accordance with IEEE/ASTM SI 10.

1.6 This standard does not purport to address all of the safety concerns, if any, associated with its use. It is the responsibility of the user of this standard to establish appropriate safety and health practices and determine the applicability of regulatory limitations prior to use.

## 2. Referenced Documents

### 2.1 ASTM Standards:<sup>2</sup>

- C1145 Terminology of Advanced Ceramics
- C1161 Test Method for Flexural Strength of Advanced Ceramics at Ambient Temperature
- C1211 Test Method for Flexural Strength of Advanced Ceramics at Elevated Temperatures
- C1239 Practice for Reporting Uniaxial Strength Data and Estimating Weibull Distribution Parameters for Advanced Ceramics

<sup>2</sup> For referenced ASTM standards, visit the ASTM website, www.astm.org, or contact ASTM Customer Service at service@astm.org. For Annual Book of ASTM Standards volume information, refer to the standard's Document Summary page on the ASTM website.

- C1292** Test Method for Shear Strength of Continuous Fiber-Reinforced Advanced Ceramics at Ambient Temperatures
- D790** Test Methods for Flexural Properties of Unreinforced and Reinforced Plastics and Electrical Insulating Materials
- D2344/D2344M** Test Method for Short-Beam Strength of Polymer Matrix Composite Materials and Their Laminates
- D3878** Terminology for Composite Materials
- E4** Practices for Force Verification of Testing Machines
- E6** Terminology Relating to Methods of Mechanical Testing
- E177** Practice for Use of the Terms Precision and Bias in ASTM Test Methods
- E220** Test Method for Calibration of Thermocouples By Comparison Techniques
- E337** Test Method for Measuring Humidity with a Psychrometer (the Measurement of Wet- and Dry-Bulb Temperatures)
- E691** Practice for Conducting an Interlaboratory Study to Determine the Precision of a Test Method
- IEEE/ASTM SI 10** American National Standard for Use of the International System of Units (SI): The Modern Metric System

### 3. Terminology

#### 3.1 Definitions:

3.1.1 The definitions of terms relating to flexure testing appearing in Terminology **E6** apply to the terms used in this test method. The definitions of terms relating to advanced ceramics appearing in Terminology **C1145** apply to the terms used in this test method. The definitions of terms relating to fiber-reinforced composites appearing in Terminology **D3878** apply to the terms used in this test method. Pertinent definitions as listed in Test Method **C1161**, Test Methods **D790**, Terminology **C1145**, Terminology **D3878**, and Terminology **E6** are shown in the following with the appropriate source given in brackets. Additional terms used in conjunction with this test method are also defined in the following.

3.1.2 *advanced ceramic, n*—highly engineered, high-performance, predominately nonmetallic, inorganic, ceramic material having specific functional attributes. **C1145**

3.1.3 *breaking force, n [F]*—The force at which fracture occurs. (In this test method, fracture consists of breakage of the test bar into two or more pieces or a loss of at least 20 % of the maximum force carrying capacity.) **E6**

3.1.4 *ceramic matrix composite, n*—material consisting of two or more materials (insoluble in one another) in which the major, continuous component (matrix component) is a ceramic, while the secondary component(s) (reinforcing component) may be ceramic, glass-ceramic, glass, metal, or organic in nature. These components are combined on a macroscale to form a useful engineering material possessing certain properties or behavior not possessed by the individual constituents.

3.1.5 *continuous fiber-reinforced ceramic composite (CFCC), n*—ceramic matrix composite in which the reinforcing phase consists of a continuous fiber, continuous yarn, or a woven fabric.

3.1.6 *flexural strength, n [FL<sup>-2</sup>]*—measure of the ultimate strength of a specified beam in bending. **C1161**

3.1.7 *four-point-1/3 point flexure, n*—a configuration of flexural strength testing where a test specimen is symmetrically loaded at two locations that are situated one third of the overall span away from the outer two support bearings.

3.1.8 *four-point-1/4 point flexure, n*—a configuration of flexural strength testing where a test specimen is symmetrically loaded at two locations that are situated one quarter of the overall span away from the outer two support bearings. **C1161**

3.1.9 *fracture strength, n [FL<sup>-2</sup>]*—the calculated flexural stress at the breaking force.

3.1.10 *modulus of elasticity, n [FL<sup>-2</sup>]*—the ratio of stress to corresponding strain below the proportional limit. **E6**

3.1.11 *proportional limit stress, n [FL<sup>-2</sup>]*—greatest stress that a material is capable of sustaining without any deviation from proportionality of stress to strain (Hooke's law).

3.1.11.1 *Discussion*—Many experiments have shown that values observed for the proportional limit vary greatly with the sensitivity and accuracy of the testing equipment, eccentricity of force application, the scale to which the stress-strain diagram is plotted, and other factors. When determination of proportional limit is required, the procedure and sensitivity of the test equipment shall be specified. **E6**

3.1.12 *slow crack growth, n*—subcritical crack growth (extension) that may result from, but is not restricted to, such mechanisms as environmentally assisted stress corrosion or diffusive crack growth.

3.1.13 *span-to-depth ratio, n [nd]*—for a particular test specimen geometry and flexure test configuration, the ratio ( $L/d$ ) of the outer support span length ( $L$ ) of the flexure test specimen to the thickness/depth ( $d$ ) of test specimen (as used and described in Test Method **D790**).

3.1.14 *three-point flexure, n*—a configuration of flexural strength testing where a test specimen is loaded at a location midway between two support bearings. **C1161**

### 4. Summary of Test Method

4.1 A bar of rectangular cross section is tested in flexure as a beam as in one of the following three geometries:

4.1.1 *Test Geometry I*—The bar rests on two supports and force is applied by means of a loading roller midway between the supports (see Fig. 1).

4.1.2 *Test Geometry IIA*—The bar rests on two supports and force is applied at two points (by means of two inner rollers), each an equal distance from the adjacent outer support point. The inner support points are situated one quarter of the overall span away from the outer two support bearings. The distance between the inner rollers (that is, the load span) is one half of the support span (see Fig. 1).

4.1.3 *Test Geometry IIB*—The bar rests on two supports and force is applied at two points (by means of two loading rollers), situated one third of the overall span away from the outer two support bearings. The distance between the inner rollers (that is, the inner support span) is one third of the outer support span (see Fig. 1).

4.2 The test specimen is deflected until rupture occurs in the outer fibers or until there is a 20 % decrease from the peak force.

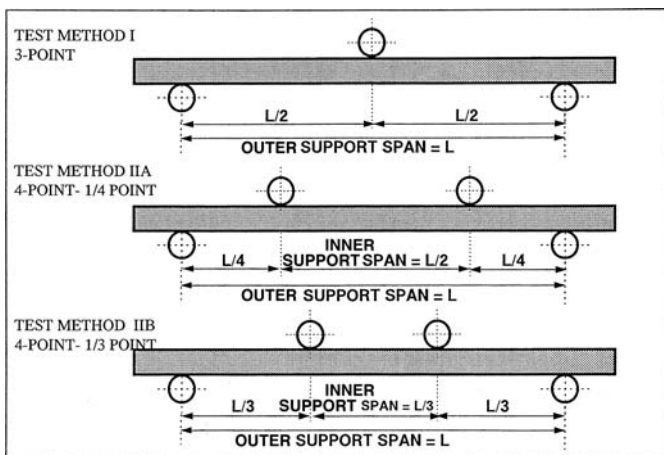

FIG. 1 Flexural Test Geometries

4.3 The flexural properties of the test specimen (flexural strength and strain, fracture strength and strain, modulus of elasticity, and stress-strain curves) are calculated from the force and deflection using elastic beam equations.

## 5. Significance and Use

5.1 This test method is used for material development, quality control, and material flexural specifications. Although flexural test methods are commonly used to determine design strengths of monolithic advanced ceramics, the use of flexure test data for determining tensile or compressive properties of CFCC materials is strongly discouraged. The nonuniform stress distributions in the flexure test specimen, the dissimilar mechanical behavior in tension and compression for CFCCs, low shear strengths of CFCCs, and anisotropy in fiber architecture all lead to ambiguity in using flexure results for CFCC material design data (1-4). Rather, uniaxial-forced tensile and compressive tests are recommended for developing CFCC material design data based on a uniformly stressed test condition.

5.2 In this test method, the flexure stress is computed from elastic beam theory with the simplifying assumptions that the material is homogeneous and linearly elastic. This is valid for composites where the principal fiber direction is coincident/transverse with the axis of the beam. These assumptions are necessary to calculate a flexural strength value, but limit the application to comparative type testing such as used for material development, quality control, and flexure specifications. Such comparative testing requires consistent and standardized test conditions, that is, test specimen geometry/thickness, strain rates, and atmospheric/test conditions.

5.3 Unlike monolithic advanced ceramics which fracture catastrophically from a single dominant flaw, CFCCs generally experience “graceful” fracture from a cumulative damage process. Therefore, the volume of material subjected to a uniform flexural stress may not be as significant a factor in determining the flexural strength of CFCCs. However, the need to test a statistically significant number of flexure test specimens is not eliminated. Because of the probabilistic nature of the strength of the brittle matrices and of the ceramic fiber in

CFCCs, a sufficient number of test specimens at each testing condition is required for statistical analysis, with guidelines for sufficient numbers provided in 9.7. Studies to determine the exact influence of test specimen volume on strength distributions for CFCCs are not currently available.

5.4 The four-point loading geometries (Geometries IIA and IIB) are preferred over the three-point loading geometry (Geometry I). In the four-point loading geometry, a larger portion of the test specimen is subjected to the maximum tensile and compressive stresses, as compared to the three-point loading geometry. If there is a statistical/Weibull character failure in the particular composite system being tested, the size of the maximum stress region will play a role in determining the mechanical properties. The four-point geometry may then produce more reliable statistical data.

5.5 Flexure tests provide information on the strength and deformation of materials under complex flexural stress conditions. In CFCCs nonlinear stress-strain behavior may develop as the result of cumulative damage processes (for example, matrix cracking, matrix/fiber debonding, fiber fracture, delamination, etc.) which may be influenced by testing mode, testing rate, processing effects, or environmental influences. Some of these effects may be consequences of stress corrosion or subcritical (slow) crack growth which can be minimized by testing at sufficiently rapid rates as outlined in 10.3 of this test method.

5.6 Because of geometry effects, the results of flexure tests of test specimens fabricated to standardized test dimensions from a particular material or selected portions of a component, or both, cannot be categorically used to define the strength and deformation properties of the entire, full-size end product or its in-service behavior in different environments. The effects of size and geometry shall be carefully considered in extrapolating the test results to other configurations and performance conditions.

5.7 For quality control purposes, results from standardized flexure test specimens may be considered indicative of the response of the material lot from which they were taken with the given primary processing conditions and post-processing heat treatments.

5.8 The flexure behavior and strength of a CFCC are dependent on its inherent resistance to fracture, the presence of fracture sources, or damage accumulation processes or combination thereof. Analysis of fracture surfaces and fractography, though beyond the scope of this test method, is highly recommended.

## 6. Interferences

6.1 A CFCC material tested in flexure may fail in a variety of distinct fracture modes, depending on the interaction of the nonuniform stress fields in the flexure test specimen and the local mechanical properties. The test specimen may fail in tension, compression, shear, or in a mix of different modes, depending on which mode reaches the critical stress level for failure to initiate. To obtain a valid flexural strength by this test method, the material must fail in the outer fiber surface in tension or compression, rather than by shear failure. The



geometry of the test specimen must be chosen so that shear stresses are kept low relative to the tension and compression stresses. This is done by maintaining a high ratio between the support span ( $L$ ) and the thickness/depth ( $d$ ) of the test specimen. This  $L/d$  ratio is generally kept at values of  $\geq 16$  for 3-point testing and  $\geq 30$  for 4-point testing. If the span-to-depth ratio is too low, the test specimen may fail in shear, invalidating the test. If the desired mode of failure is shear, then an appropriate shear test method should be used, such as Test Method [C1292](#) or [D2344/D2344M](#).

6.2 Time-dependent phenomena, such as stress corrosion and slow crack growth, can interfere with the determination of the flexural strength at room and elevated temperatures. Creep phenomena also become significant at elevated temperatures. Both mechanisms can cause stress relaxation in flexure test specimens during a strength test, thereby causing the elastic formula calculations to be in error. Test environment (vacuum, inert gas, ambient air, etc.) including moisture content (for example, relative humidity) may have an accelerating effect on stress corrosion and slow crack growth. Testing to evaluate the maximum strength potential of a material should be conducted in inert environments or at sufficiently rapid testing rates, or both, so as to minimize slow crack growth effects. Conversely, testing can be conducted in environments and testing modes and rates representative of service conditions to evaluate material performance under use conditions. When testing is conducted in uncontrolled ambient air with the intent of evaluating maximum strength potential, monitor and report the relative humidity and temperature.

6.3 Surface preparation of test specimens, although normally not considered a major concern in CFCCs, can introduce fracture sources on the surface which may have pronounced effects on flexural mechanical properties and behavior (for example, elastic and nonelastic regions of the stress-strain curve, flexural strength and strain, proportional limit stress and strain, etc.). Machining damage introduced during test specimen preparation can be either a random interfering factor in the determination of flexure strength of test specimen or an inherent part of the strength characteristics being measured. Surface preparation can also lead to the introduction of residual stresses. Universal or standardized test methods of surface preparation for CFCCs do not exist. It should be understood that final machining steps may or may not negate machining damage introduced during the initial machining. Thus, test specimen fabrication history may play an important role in the measured strength distributions and should be reported. In addition, the nature of fabrication used for certain composites (for example, chemical vapor infiltration, hot pressing, and preceramic polymer lamination) may require the testing of specimens in the as-processed condition (that is, it may not be possible or appropriate to machine the test specimen faces).

6.4 Fractures that initiate outside the uniformly stressed region of a flexure test specimen (between the inner support points in four-point and under the center point in three-point) may be due to factors such as stress concentrations or strength limiting features in the microstructure of the test specimen. Fractures which do occur outside the uniformly stressed sections will normally constitute invalid tests. If the flexure

data is used in the context of estimating Weibull parameters then appropriate computational methods shall be used for such censored data. These methods are outlined in Practice [C1239](#).

6.5 Flexural strength at elevated temperature may be strongly dependent on force application rate as consequence of creep, stress corrosion, or slow crack growth effects. This test method measures the flexural strength at high force application rates in order to minimize these effects.

## 7. Apparatus

7.1 *Testing Machine*—Test the flexure test specimens in a properly calibrated testing machine that can be operated at constant rates of cross-head motion over the range required. The error in the force measuring system shall not exceed  $\pm 1\%$  of the maximum force being measured. The force-indicating mechanism shall be essentially free from inertial lag at the cross-head rate used. Although not recommended, if the cross-head displacement is used to determine the test specimen deflection for the three-point loading geometry, determine the compliance of the load train (see [Appendix X1](#)), so that appropriate corrections can be made to the deflection measurement. Equip the system with a means for retaining the readout of the maximum force as well as a record of force versus time. Verify the accuracy of the testing machine in accordance with Practices [E4](#).

7.2 *Loading Fixtures*—The outer support span and the desired test geometry determine the dimensions and geometry of the loading fixture. Select the fixture geometry from one of three configurations: 3-point, 4-point- $\frac{1}{4}$  point, and 4-point- $\frac{1}{3}$  point. The thickness of test specimen to be tested determines the critical outer span dimension ( $L$ ) of the loading fixture. The overall dimensions of the test specimen and the required inner and outer support spans are selected based on the specimen thickness, the desired test geometry, and the required span-to-depth ratio. [Table 1](#), [Table 2](#), and [Table 3](#) give the recommended support spans for different span/depth ratios, test specimen thicknesses, and the three test geometries. Loading fixtures shall be wide enough to support the entire width of the selected test specimen geometry.

7.2.1 Ensure that the design and construction of the fixtures produces even and uniform forces along the bearing-to-specimen surfaces. A rigid loading fixture is permitted, if it is designed and aligned so that forces are evenly applied to the test specimen, particularly for four-point loading geometries. It is preferred, however, that load fixtures with an articulating geometry be used. An articulated loading fixture reduces or eliminates uneven force application caused by geometry variations of the test specimen or misalignment of the test fixtures.

7.2.2 *Semi-Articulating Fixtures*—Test specimens prepared in accordance with and meeting the parallelism requirement of [9.4](#) may be tested in a semi-articulating fixture. The bearing cylinders shall be parallel to each other within 0.1 mm over their length. (A representative design for a four-point fixture is illustrated in [Fig. 2](#).)

7.2.3 *Fully Articulating Fixture*—Test specimens with slight warp, twist, or bowing may not meet the parallelism requirements of [9.4](#). It is recommended that such test specimens be

**TABLE 1 Recommended Dimensions for Test Specimens of 9.1 for Various outer support span-to-Depth Ratios—Test Geometry I (3-Point)**

Nominal test specimen Depth/ Thickness (mm)	test specimen Width (mm)	test specimen Length (mm)	Support Span (mm)	Rate of Cross-Head <sup>A</sup> Motion (mm/s)
<i>L/d = 16 to 1</i>				
1	3	26	16	0.04
2	6	45	32	0.09
3	9	60	48	0.13
4	12	75	64	0.17
5	15	90	80	0.21
6	18	105	96	0.26
10	30	180	160	0.43
15	45	270	240	0.64
20	60	360	320	0.86
<i>L/d = 32 to 1</i>				
1	3	42	32	0.17
2	6	75	64	0.34
3	9	105	96	0.51
4	12	145	128	0.68
5	15	180	160	0.86
6	18	210	192	1.03
10	30	360	320	1.71
15	45	530	480	2.57
20	60	710	640	3.42
<i>L/d = 40 to 1</i>				
1	3	50	40	0.27
2	6	90	80	0.53
3	9	135	120	0.80
4	12	180	160	1.07
5	15	220	200	1.34
6	18	265	240	1.60
10	30	440	400	2.67
15	45	660	600	4.01
20	60	880	800	5.34
<i>L/d = 60 to 1</i>				
1	3	70	60	0.60
2	6	135	120	1.20
3	9	200	180	1.80
4	12	265	240	2.40
5	15	330	300	3.01
6	18	400	360	3.61
10	30	660	600	6.01
15	45	1000	900	9.02
20	60	1350	1200	12.02

<sup>A</sup> Rates indicated are for a strain rate of 0.001 mm/mm-s.

**TABLE 2 Recommended Dimensions for Test Specimens of 9.1 for Various outer support span-to-Depth Ratios—Test Geometry II-A (4 Point-¼ Point)**

Nominal test specimen Depth/ Thickness (mm)	test specimen Width (mm)	test specimen Length (mm)	Support Span (mm)	force Span (mm)	Rate of Cross-Head <sup>A</sup> Motion (mm/s)
<i>L/d = 16 to 1</i>					
1	3	26	16	8	0.04
2	6	45	32	16	0.09
3	9	60	48	24	0.13
4	12	75	64	32	0.17
5	15	90	80	40	0.21
6	18	105	96	48	0.26
10	30	180	160	80	0.43
15	45	270	240	120	0.64
20	60	360	320	160	0.86
<i>L/d = 32 to 1</i>					
1	3	42	32	16	0.17
2	6	75	64	32	0.34
3	9	105	96	48	0.51
4	12	145	128	64	0.68
5	15	180	160	80	0.86
6	18	210	192	96	1.03
10	30	360	320	160	1.71
15	45	530	480	240	2.57
20	60	710	640	320	3.42
<i>L/d = 40 to 1</i>					
1	3	50	40	20	0.27
2	6	90	80	40	0.53
3	9	135	120	60	0.80
4	12	180	160	80	1.07
5	15	220	200	100	1.34
6	18	265	240	120	1.60
10	30	440	400	200	2.67
15	45	660	600	300	4.01
20	60	880	800	400	5.34
<i>L/d = 60 to 1</i>					
1	3	70	60	30	0.60
2	6	135	120	60	1.20
3	9	200	180	90	1.80
4	12	265	240	120	2.40
5	15	330	300	150	3.01
6	18	400	360	180	3.61
10	30	660	600	300	6.01
15	45	1000	900	450	9.02
20	60	1350	1200	600	12.02

<sup>A</sup> Rates indicated are for a strain rate of 0.001 mm/mm-s.

tested in a fully articulating fixture. (A representative design for a four-point fixture is illustrated in Fig. 3.)

7.2.4 The test fixture shall be made of a material that is suitably rigid and resistant to permanent deformation at the forces and temperatures of testing. The test fixture material shall be essentially inert at the desired test temperatures.

7.3 Inner/Outer/Center Support Bearings—In both the three-point and four-point flexure test fixtures, use cylindrical bearings for support of the test specimen and for force application. The cylinders shall be made of a tool steel or a ceramic with an elastic modulus between 200 and 400 GPa and a flexural strength no less than 275 MPa. The inner/outer/center support bearing cylinders shall remain elastic over the force and temperature ranges used.

7.3.1 Ensure that the inner/outer/center support bearings have cylindrical surfaces that are smooth and parallel along their length to an accuracy of ±0.05 mm. In order to avoid excessive indentation or crushing failure directly under the bearing contact surface, the bearing-surface diameter shall be

at least 3.0 mm. The bearing-surface diameter shall be approximately 1.5 times the beam depth of the test specimen size used. If the test specimen has low through-thickness compressive strength, the cylinder diameter shall be four times the beam thickness to prevent crushing at the force application points.

NOTE 1—In such circumstances, however, there is a possible error due to contact-point tangency shift due to the change in force application point as the test specimen deflects during force application. The magnitude of this error can be estimated from Ref. 5.

7.3.2 Position the outer support bearing cylinders carefully such that the outer support span distance is accurate to a tolerance of 1 %. The force application bearing for the three-point configuration shall be positioned midway between the support bearings to an accuracy of 1 % of the outer span length. The force application (inner) bearings for the four-point

**TABLE 3 Recommended Dimensions for Test Specimens of 9.1 for Various outer support span-to-Depth Ratios—Test Geometry II-B (4 Point-1/3 Point)**

Nominal test specimen Depth/Thickness (mm)	test specimen Width (mm)	test specimen Length (mm)	Support Span (mm)	force Span (mm)	Rate of Cross-Head <sup>A</sup> Motion (mm/s)
<i>L/d = 16 to 1</i>					
1	3	26	16	5.3	0.05
2	6	45	32	10.6	0.09
3	9	60	48	16.0	0.14
4	12	75	64	21.3	0.19
5	15	90	80	26.7	0.24
6	18	105	96	32.0	0.28
10	30	180	160	53.3	0.47
15	45	270	240	80.0	0.71
20	60	360	320	106.7	0.95
<i>L/d = 32 to 1</i>					
1	3	42	32	10.7	0.19
2	6	75	64	21.3	0.38
3	9	105	96	32.0	0.57
4	12	145	128	42.7	0.76
5	15	180	160	53.3	0.95
6	18	210	192	64.0	1.14
10	30	360	320	106.7	1.89
15	45	530	480	160.0	2.84
20	60	710	640	213.3	3.79
<i>L/d = 40 to 1</i>					
1	3	50	40	13.3	0.30
2	6	90	80	26.7	0.59
3	9	135	120	40.0	0.89
4	12	180	160	53.3	1.18
5	15	220	200	66.7	1.48
6	18	265	240	80.0	1.78
10	30	440	400	133.3	2.96
15	45	660	600	200.0	4.44
20	60	880	800	266.7	5.92
<i>L/d = 60 to 1</i>					
1	3	70	60	20.0	0.67
2	6	135	120	40.0	1.33
3	9	200	180	60.0	2.00
4	12	265	240	80.0	2.66
5	15	330	300	100.0	3.33
6	18	400	360	120.0	4.00
10	30	660	600	200.0	6.66
15	45	1000	900	300.0	9.99
20	60	1350	1200	400.0	13.32
25	75	1650	1500	500.0	16.65

<sup>A</sup> Rates indicated are for a strain rate of 0.001 mm/mm-s.

configurations shall be properly positioned with respect to the support (outer) bearings to an accuracy of 1 % of the outer span length.

7.3.3 For articulating fixtures, the bearing cylinders shall be free to rotate in order to relieve frictional constraints (with the exception of the center bearing cylinder in three-point flexure, which need not rotate). This can be accomplished as shown in Fig. 2 and Fig. 3. Note that the outer support bearings roll outward, and the inner support bearings roll inward.

NOTE 2—In general, fixed-pin fixtures have frictional constraints that have been shown to cause a systematic error on the order of 5 to 15 % in flexural strength for monolithic ceramics. Since this error is systematic, it will lead to a bias in estimates of mean strength. Rolling-pin fixtures are required for articulating fixtures by this test method. It is recognized that they may not be feasible for rigid fixtures, in which case fixed-pin fixtures may be used. But this shall be stated explicitly in the report.

7.4 *Deflection Measurement*—The test system shall have a means of measuring test specimen deflection, appropriate for the geometry and the test temperature. The preferred device measures actual deflection at the centerline of the test specimen support span, using direct contact or optical function. The calibrated range of the deflectometer shall be such that the linear strain region of the material tested will represent a minimum of 20 % of the calibrated range. The deflectometer shall have an accuracy of 1 % of the maximum deflection measured.

7.5 *Strain Measurement*—The use of strain gages for ambient testing is acceptable provided that the test material surface is smooth with little open porosity and that the applied strain gage is large enough to cover a representative area of the composite test specimen. Follow the manufacturer’s recommendations regarding application and performance. Strain gages shall not interfere with the deflection measuring device.

7.6 *Heating Apparatus*—For elevated-temperature testing, any furnace that meets the temperature uniformity and control requirements described below shall be acceptable. A furnace whose heated cavity is large enough to accept the entire test fixture is preferred.

7.6.1 The furnace shall be capable of establishing and maintaining a constant temperature (within  $\pm 5^{\circ}\text{C}$ ) during each test period. Measure the temperature uniformity of the test specimen across the inner support span section extending from the center to 5 mm inside the outer support points. The temperature uniformity along the inner support span shall be within  $\pm 5^{\circ}\text{C}$  test temperatures up to and including  $500^{\circ}\text{C}$  and  $\pm 1\%$  for test temperatures above  $500^{\circ}\text{C}$ .

7.6.1.1 In order to determine conformance to the temperature control and uniformity requirements, determine a temperature profile using thermocouples to measure the test specimen temperature at three locations—the test specimen center point and two points 5 mm inside the outer support points.

7.6.1.2 Determine temperature uniformity for all elevated-temperature testing and recheck the uniformity if any of the following parameters are changed: heating method, test specimen material, sample geometry, or test temperature, or combination thereof.

7.6.2 *Temperature Measurement*—The use of thermocouples (TC) is recommended and preferred; however, the use of optical pyrometry is acceptable. For TC measurement, elevated-temperature tests require the placement of one TC at the test specimen center. The sheathed TC should be within 1 mm of the test specimen. The use of two additional thermocouples at locations 5 mm inside the outer support points is recommended to check for temperature uniformity. Thermocouples shall be calibrated in accordance with Test Method E220 with a verified accuracy of  $\pm 5^{\circ}\text{C}$ .

7.6.3 *Atmosphere Control*—The furnace may have an air, inert, or vacuum environment, as required. If an inert or vacuum environment is used, and it is necessary to apply force through a bellows, fitting, or seal, verify that force losses or errors do not exceed 1 % of the expected failure forces.

7.7 *Data Acquisition*—At the minimum, obtain an autographic record of the applied force and center-point deflection

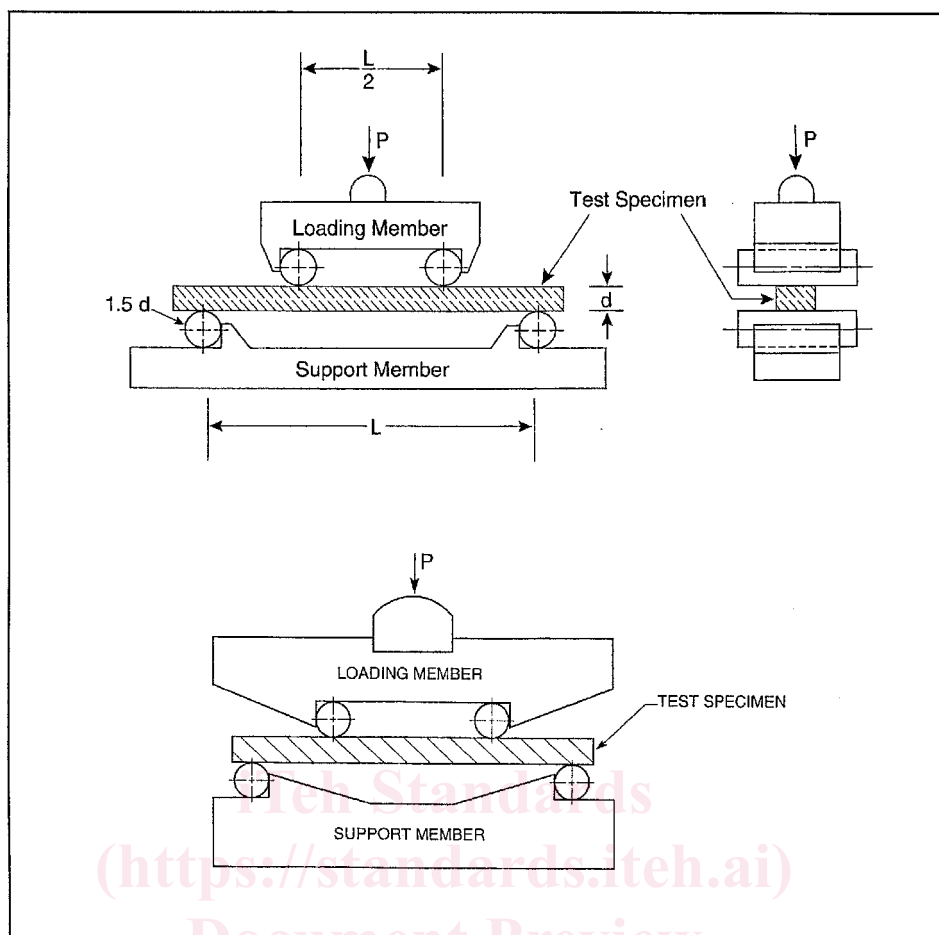

FIG. 2 Semi-Articulating Flexure Fixtures

ASTM C1341-06

or sample strain versus time for the specified cross-head rate. Either analog chart recorders or digital data acquisition systems may be used for this purpose, although a digital record is recommended for ease of subsequent data analysis. Ideally, an analog chart recorder or plotter should be used in conjunction with the digital data acquisition system to provide an immediate record of the test as a supplement to the digital record. Ensure that the recording devices have an accuracy of 0.1 % of full scale and have a minimum data acquisition rate of 10 Hz with a response of 50 Hz deemed more than sufficient.

**7.8 Dimension-Measuring Devices**—Micrometers and other devices used for measuring linear dimensions shall be accurate and precise to at least one half the smallest unit to which the individual dimension is required to be measured. For the purposes of this test method, measure the cross-sectional dimensions to within 0.02 mm with a measuring device with an accuracy of 0.01 mm.

**7.9 Calibration**—Calibration of equipment shall be provided by the supplier with traceability maintained to the National Institute of Standards and Technology (NIST). Recalibration shall be performed with a NIST-traceable standard on all equipment on a six-month interval or whenever accuracy is in doubt.

**8. Hazards**

8.1 During the conduct of this test method, the possibility of flying fragments of broken test specimens may be high. The brittle nature of advanced ceramics and the release of strain energy contribute to the potential release of uncontrolled fragments upon fracture. The containment/retention of these fragments for later fractographic reconstruction and analysis is highly recommended.

8.2 Exposed fibers at the edges and faces of CFCC test specimens may present a hazard due to the sharpness and brittleness of the ceramic fibers. Inform all individuals who handle these materials of potential hazards and the proper handling techniques.

**9. Test Specimens**

9.1 Selection of a specific test specimen geometry depends on many factors—the geometry of available material, the expected mechanical properties, the geometry of the final component, geometry limitations in the test equipment, and cost factors.

9.1.1 Test specimens must have a span-to-depth ratio ( $L/d$ ) that produces tensile or compressive failure in the outer fiber surfaces of the sample under the bending moment. If the  $L/d$



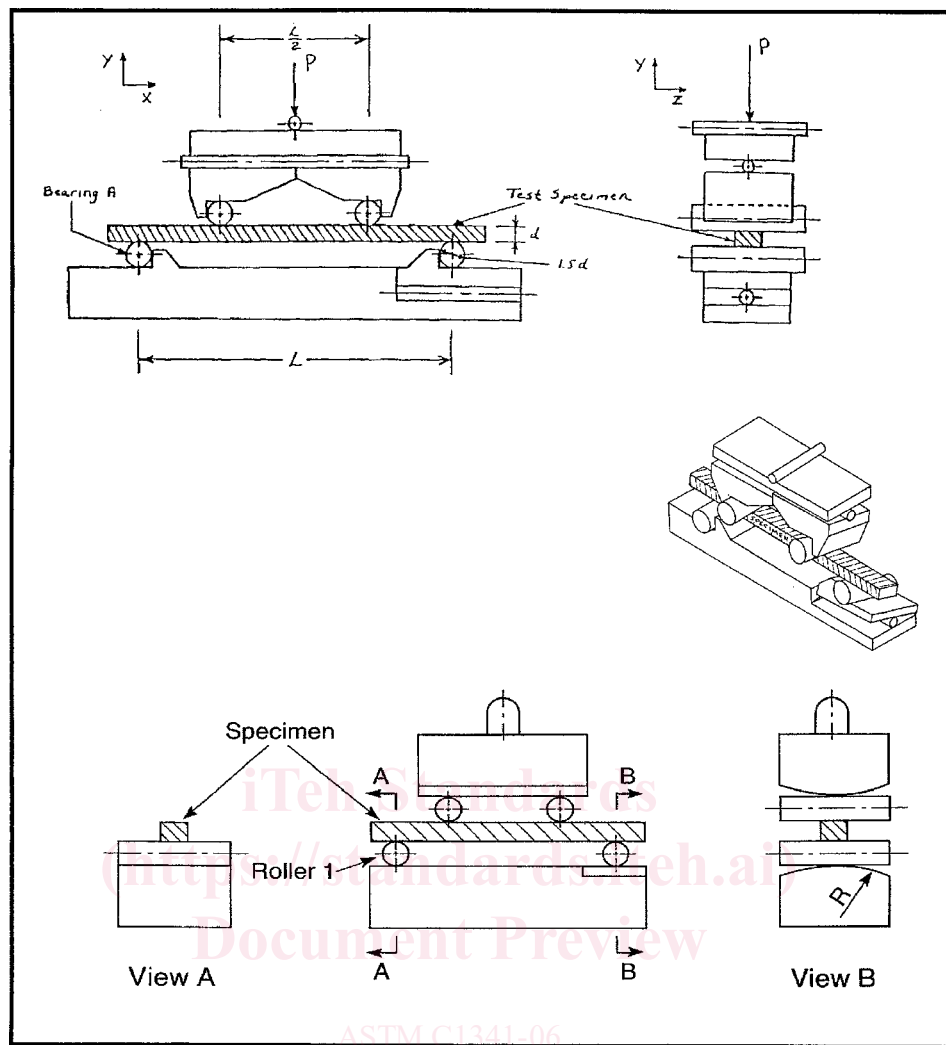

NOTE 1—One of the four inner/outer/center support bearings (for example, Roller No. 1) shall not articulate about the x-axis. The other three will provide the necessary degrees of freedom. The radius  $R$  in the bottom fixture shall be sufficiently large such that contact stresses on the roller are minimized.

FIG. 3 Fully Articulating Flexure Fixture

ratio is too low, the sample may fail due to shear stress, producing an invalid test. Three recommended  $L/d$  ratios are 16:1, 32:1, and 40:1. Materials with lower shear strength require higher  $L/d$  ratios. A 16:1 ratio is a recommended starting point for three-point testing (3). A 32:1 ratio is a recommended starting point for four-point testing (3). For CFCCs with very low interlaminar shear strengths ( $<3.5$  MPa) based on low matrix density or shear failure at interfaces,  $L/d$  ratios of 60 may be necessary to prevent shear failures. If shear failures are observed during initial testing, a modified test geometry with a higher  $L/d$  ratio (for example, 40:1 or 60:1) shall be used for subsequent tests.

9.1.2 Prepare the test specimens with dimensions determined from the appropriate tables (Table 1 for three-point bending, Table 2 for four-point- $1/4$  point bending, and Table 3 for four-point- $1/3$  point bending). Determine the minimum dimensions for specimen width and length and the support span based on the test specimen thickness and the desired  $L/d$  ratio.

9.1.3 Test specimen width shall not exceed one fourth of the support span for specimens greater than 3 mm in depth. The test specimen shall be long enough to allow for overhang past the outer supports of at least 5 % of the support span, but in no case less than 5 mm on each end. Overhang shall be sufficient to minimize shear failures in the test specimen ends and to prevent the test specimen from slipping through the supports at large center-point deflections.

9.1.4 Ensure that composites with woven fiber architecture have a test specimen width that is equal to or greater than twice the width of the repeating unit of the weave in the width dimension.

9.1.5 Anisotropy in mechanical properties of composites is strongly affected by fiber architecture. Alignment of the long axis of the flexure test specimen with a principal weave direction must be controlled and monitored. Measure the alignment to an angular precision of  $\pm 5$  degrees.



9.2 *Fabrication Method*—The test specimens may be cut from sheets, plates, or molded shapes, or may be formed directly to the required finished dimensions.

9.3 *Finishing Method*—Depending upon the application of the strength data, use one of the following test specimen finishing procedures: as-fabricated, application matched, customary, and standard. These finishing details are described in **Annex A2**. Regardless of the preparation procedure used, sufficient details regarding the procedure shall be reported to allow replication.

9.3.1 For a given set of test specimens cut from a sample panel, prepare and record a cutting diagram showing the location and orientation of individual test specimens with respect to the starting panel geometry and the fiber/fabric orientation.

9.4 *Dimensional Tolerances*—The cross-sectional tolerance for cut/machined dimensions shall be  $\pm 0.1$  mm or 0.5 % of the dimension, whichever is greater. Parallelism tolerances on cut/machined faces are 0.02 mm or 0.5 %, whichever is greater.

9.5 *General Examination*—The mechanical responses of CFCCs are strongly affected by geometry, porosity, and discontinuities. Inspect and characterize each test specimen carefully for nonuniformity in major dimensions, warp, twist, and bowing, porosity (volume % and size distribution), discontinuities such as delaminations, cracks, etc., and surface roughness on as-prepared and finished surfaces. Record these observations/measurements and include them in the final report as well as any results of nondestructive evaluation.

9.6 *Handling Precaution*—Exercise care in the storage and handling of finished test specimens to avoid the introduction of random and severe fracture sources. In addition, consider pre-test storage of test specimens in controlled environments or desiccators to avoid unquantifiable environmental degradation of test specimens prior to testing.

9.7 *Number of Test Specimens*—A minimum of ten test specimens is required for the purposes estimating a mean. A greater number of test specimens may be necessary if the estimates regarding the form of the strength distribution are required. If material cost or test specimen availability limits the number of tests to be conducted, fewer tests can be conducted to develop an indication of material properties.

## 10. Procedure

10.1 *Test Specimen Dimensions*—Determine the thickness and width of each test specimen to within 0.02 mm. Measure the test specimen at least three different cross-sectional planes in the stressed section (between the outer force application points). It is recommended that machined surfaces be measured either optically (for example, by an optical comparator) or mechanically, using a flat, anvil-type micrometer. Measure rough or as-processed surfaces with a double-ball interface micrometer with a ball radius of 4 mm. In all cases the resolution of the instrument shall meet the requirements specified in 7.8. Measure the test specimens with care to prevent surface damage. Record and report the measured dimensions and locations of the measurements for use in the calculation of the flexure stress. For the three-point loading

geometry, use the dimensions at the center force application point in the stress calculations. For four-point loading geometries, use the average of the multiple measurements in the stress calculations.

10.2 In some cases it is desirable, but not required, to measure surface finish to quantify the condition of as-prepared and finished surfaces. Such methods as contacting profilometry can be used to determine surface roughness along the tensile surface and parallel to the tensile axis. When quantified, surface roughness shall be reported.

10.3 *Test Modes and Rates*—Test modes and rates may have distinct and strong influences on fracture behavior of advanced ceramics even at ambient temperatures depending on test environment or condition of the test specimen. Test modes may involve force, displacement, or strain control. Recommended rates of testing are projected to be sufficiently rapid to obtain the maximum possible flexural strength of the material. However, rates other than those recommended herein may be used to evaluate rate effects. In all cases, report the test mode and rate.

10.3.1 For monolithic advanced ceramics exhibiting linear elastic behavior, fracture is characterized by a weakest-link fracture mechanism generally attributed to stress-controlled fracture from Griffith-like flaws. Therefore, a force-controlled test, with force generally related directly to tensile stress, is the preferred test control mode. However, the nonlinear stress-strain behavior characteristic of the graceful fracture process of CFCCs indicates a cumulative damage process which is strain dependent. Generally, displacement or strain controlled-tests are employed in such cumulative damage or yielding deformation processes to prevent a “runaway” condition (that is, rapid uncontrolled deformation and fracture) characteristic of force or stress controlled tests. Thus, to identify the potential toughening mechanisms under controlled fracture of the CFCC, displacement or strain control may be preferred. However, for sufficiently rapid test rates, differences in the fracture process may not be apparent and any of these test control modes may be appropriate.

10.3.2 *Strain Rate*—Strain is the independent variable in nonlinear mechanisms such as yielding. As such, strain rate is a method of controlling tests of deformation processes to avoid runaway conditions. For the linear elastic region of CFCCs, strain rate can be related to stress rate such that:

$$\dot{\epsilon} = dc/dt = \dot{\sigma}/E \quad (1)$$

where:

- $\dot{\epsilon}$  = the strain rate in the units of  $s^{-1}$ ,
- $\epsilon$  = the maximum strain in the outer fibers,
- $t$  = time in units of s,
- $\dot{\sigma}$  = the maximum stress rate in the outer fibers in units of  $MPa s^{-1}$ , and
- $E$  = the elastic modulus of the CFCC in units of MPa.

Strain-controlled tests can be accomplished using a deflectionmeter contacting the center line of the inner support span of the test specimen to produce the control signal. Strain rates on the order of  $500 \times 10^{-6}$  to  $5000 \times 10^{-6} s^{-1}$  are recommended to minimize environmental and force application rate effects when testing in ambient air. Alternately, strain rates shall be

selected to produce final fracture in 5 to 10 s to minimize environmental and force application rate effects. Elevated testing temperatures may enhance the environmental or force application rate effects, or both. Minimize those effects by increasing the strain rate if the initial material evaluation shows such effects.

**10.3.3 Displacement Rate**—The differences in size of each test specimen geometry require a different cross-head rate for an assigned strain rate. Note that as the test specimen begins to deform in a nonlinear mode, the strain rate in the outer fibers of the test specimen will change even though the rate of motion of the cross head remains constant. For this reason, displacement rate controlled tests can give only an approximate value of the imposed strain rate. Displacement control mode is defined as the control of, or free-running displacement of, the test machine cross head to mechanically apply force to the test specimen. **Table 1**, **Table 2**, or **Table 3** provide displacement rates for a nominal strain rate of  $1000 \times 10^{-6} \text{ s}^{-1}$  for the different test geometries. If the tables are not used, calculate the rate of cross-head displacement as follows, depending on test geometry used.

$$\text{Test Geometry I (3 - Point)} \quad \dot{D} = 0.167 \dot{\epsilon} L^2/d \quad (2)$$

$$\text{Test Geometry IIA} \left( 4 - \text{Point} - \frac{1}{4} \text{Point} \right) \quad \dot{D} = 0.167 \dot{\epsilon} L^2/d \quad (3)$$

$$\text{Test Geometry IIB} \left( 4 - \text{Point} - \frac{1}{3} \text{Point} \right) \quad \dot{D} = 0.185 \dot{\epsilon} L^2/d \quad (4)$$

where:

$\dot{D}$  = rate of cross-head motion, mm/s (for rates in mm/min, multiply by 60),

$L$  = outer support span, mm,

$d$  = test specimen thickness, mm, and

$\dot{\epsilon}$  = desired strain rate of the outer fiber, mm/mm·s.

A strain rate of  $1000 \times 10^{-6} \text{ s}^{-1}$  is recommended for initial testing.

#### 10.4 Conducting the Flexure Test:

**10.4.1** At the start of each test sequence, assemble and align the appropriate flexure test fixture in the required testing configuration. Align and measure the force application point locations so that inner and outer support spans are within 1 % of the required position values.

**10.4.2 Test Specimen Loading for Ambient Testing**—Mark the test specimen with an indelible marker as to top and bottom surfaces at points beyond the outer support span. This will assist in later identifying tensile and compressive loaded faces. Carefully place each test specimen into the test fixture to preclude possible damage and to ensure alignment of the specimen in the test fixture.

**10.4.3 Test Specimen Loading for Elevated-Temperature Testing**—The test specimen may be loaded into either a cold furnace with the whole system then heated to operating temperature or directly into a hot furnace. In hot furnace loading, take care to minimize or eliminate the thermal shock damage to the test specimen. See **Annex A3** for discussion of hot furnace loading issues.

**10.4.3.1** Raise the temperature of the test furnace linearly to the test temperature within a period of  $20 \pm 5$  min. Ensure that

overshoot of the test temperature does not exceed  $5^\circ\text{C}$  for test temperatures below  $500^\circ\text{C}$  and 1 % for test temperatures above  $500^\circ\text{C}$  and does not exceed a duration of 15 s. Stabilize the test temperature for a duration of  $20 \pm 5$  min prior to applying force to the test specimen. Temperature overshoot shall be included in timing the stabilization period. Record any temperature excursions occurring after the overshoot which exceed 1 % of the test temperature.

**10.4.4 Preparations for Testing**—Set and check the cross-head displacement rate on the test machine. Set and check the data collection system for data logging. Position, check, and zero the displacement/strain measuring system.

**10.4.5** Preload the test specimen to remove the slack from the load train. The amount of preload will depend on the material and test specimen geometry, and therefore must be determined for each situation. Preload shall not exceed 5 % of the breaking strength. For ambient condition testing, check the contact between the bearings and the specimen to ensure even-line force application across the width of the specimen. For ambient testing, mark the specimen to identify the points of force application and the front face of the specimen. Carefully drawn colored pencil marks are suitable. The marks are used as a reference to locate the point of fracture.

**10.4.6** Determine and record the ambient temperature and the relative humidity in accordance with Test Method **E337**.

**10.4.7 Conducting the Test**—Determine and record the test temperature. Initiate the data acquisition. Start the force application. Continue the test until the specimen breaks into two pieces or there is a drop of 20 % from the maximum observed force. Record the maximum force and the fracture force. After test completion disable the action of the test machine and the data acquisition system. For elevated-temperature tests, permit the sample and furnace to cool to a suitable handling temperature. Carefully remove the fractured specimen and any fragments from the test fixture, and retain them for later analysis. Take care not to damage the fracture surfaces by preventing them from contact with each other or other objects.

**10.4.8** Note the general location of the fracture point (center, left/right of center, out-of-span). If measured fracture location data is desired, measure and report the fracture location relative to the support span to  $\pm 1$  mm. Use the convention that the midpoint between the two outer spans is 0 mm with positive (+) measurements toward the right of the specimen as tested (and marked) and negative (–) measurements toward the left of the specimen as tested (and marked).

**10.4.9** In addition to the location, carefully note the mode of the fracture initiation and crack extension. Fracture may initiate on the tensile (lower) face, on the compression (upper) face of the bar, or by shear failure (see **Fig. 4**). The bar may fail by a sequential combination of modes. The tensile fracture crack may extend toward the neutral axis directly or may deflect along low-strength planes such as interlaminar regions.

**10.4.10 Invalid Tests**—In Test Geometry I (three-point testing), failure may occur beyond the point of maximum stress (2 mm or 5 % of the outer-span length away from the center point, whichever is greater). Note and record data from such a failure