



## Standard Specification for Modular Gage Boards<sup>1</sup>

This standard is issued under the fixed designation F707/F707M; the number immediately following the designation indicates the year of original adoption or, in the case of revision, the year of last revision. A number in parentheses indicates the year of last reapproval. A superscript epsilon ( $\epsilon$ ) indicates an editorial change since the last revision or reapproval.

*This standard has been approved for use by agencies of the Department of Defense.*

### 1. Scope

1.1 This specification covers modular gage boards for mounting 89-mm (3½-in.), 114-mm (4½-in.), 152-mm (6-in.), and 216-mm (8½-in.) dial size pressure gages and dial thermometers for miscellaneous shipboard applications.

1.2 Gage boards ordered under this specification are suitable for pressure gages and dial thermometers with either turret or back flanged type cases and with either back or bottom connections (see [Appendix X1](#)).

1.3 Gage mounting dimensions shall be in accordance with ANSI B 40.01

1.4 The values stated in SI units are to be regarded as the standard. The inch-pound values given in parentheses are for information only.

NOTE 1—Gage boards covered by this specification are those normally supplied by the shipyard as opposed to the shipyard's equipment subcontractor.

### 2. Referenced Documents

#### 2.1 Other Standards:

**B 40.1** Gages, Pressure and Vacuum, Indicating Dial Type—Elastic Element<sup>2</sup>

**Fed Spec. TT-P-645** Primer, Paint, Zinc-Chromate, Alkyd Type<sup>3</sup>

**DoD-P-15328** Primer (Wash), Pretreatment (Formula No. 117 for Metals) (Metric)<sup>3</sup>

### 3. Classification

3.1 Gage boards are furnished in two types as follows:

<sup>1</sup> This specification is under the jurisdiction of ASTM Committee F25 on Ships and Marine Technology and is the direct responsibility of Subcommittee F25.11 on Machinery and Piping Systems.

Current edition approved Feb. 1, 2006. Published February 2006. Originally approved in 1981. Last previous edition approved in 2001 as F707/F707M – 94 (2001). DOI: 10.1520/F0707\_F0707M-94R06.

<sup>2</sup> Available from American National Standards Institute, 25 W. 43rd St., 4th Floor, New York, NY 10036.

<sup>3</sup> Available from Standardization Documents Order Desk, Bldg. 4 Section D, 700 Robbins Ave., Philadelphia, PA 19111-5094, Attn: NPODS.

3.1.1 *Type I*—Gage boards for mounting 89-mm (3½-in.) and 114-mm (4½-in.) dial size gages as specified in Section 5.

3.1.2 *Type II*—Gage boards for mounting 152-mm (6-in.) and 216-mm (8½-in.) dial size gages as specified in Section 5.

3.2 Gage boards are furnished in two grades as follows:

3.2.1 *Grade a*—Gage boards are to be manufactured from carbon steel as specified in Section 5.

3.2.2 *Grade b*—Gage boards are to be manufactured from aluminum alloy as specified in Section 5.

### 4. Ordering Information

4.1 Orders for gage boards under this specification shall include the following information:

4.1.1 Quantity (number of gage boards),

4.1.2 Name of item (gage board),

4.1.3 *Type* (Type I or Type II as specified by purchaser), see 3.1.1 and 3.1.2,

4.1.4 *Grade* (Grade a or Grade b as specified by purchaser), see 3.2.1 and 3.2.2,

4.1.5 *Paint* (as specified by purchaser), see 7.2,

4.1.6 *Drilling for gage mounting* (as specified by purchaser), see 5.1.1, and

4.1.7 ASTM designation and date of issue.

### 5. Materials and Manufacture

5.1 Unless otherwise specified the gage boards shall be manufactured from 11-gage (manufacturers standard gage) carbon steel for Grade a and 3 mm (⅛ in.) thick aluminum alloy for Grade b. Materials shall be capable of being bent at room temperature through 90° in any direction to an inside radius equal to its thickness without cracking on the outside of the bent portion.

5.1.1 Unless otherwise specified, Type I gage boards shall be drilled for mounting both 89-mm (3½-in.) and 114-mm (4½-in.) dial size gages and Type II gage boards shall be drilled for mounting both 152-mm (6-in.) and 216-mm (8½-in.) dial size gages. When specified by the purchaser, drilling shall be limited to one size gage for either Type I or Type II gage boards (see 4.1.6).

**6. Dimensions and Permissible Variations**

6.1 The dimensions of the gage board shall not vary by more than 0.4 mm ( $\pm 1/64$  in.) except as noted in Fig. 1 and Fig. 2.

**7. Workmanship, Finish and Appearance**

7.1 The gage boards shall have a workmanlike finish free of scale, burrs, cracks, and other defects affecting serviceability or appearance.

7.2 If paint is not specified by the purchaser, Grade a gage boards shall be supplied with a coat of zinc chromate primer in accordance with Federal Specification TT-P-645, Formula 84 or equal (yellow) 0.038-mm (1.5-mils) dry film thickness. Grade b gage boards shall be supplied with one pretreatment wash coat in accordance with Specification DOD-P-15328

Formula 117 or equal (dark green) 0.013-mm (0.5-mils) dry film thickness and one coat of zinc chromate primer in accordance with Federal Specification TT-P-645 Formula 84D or equal (dark green) 0.013 mm (1.5-mils) dry film thickness.

**8. Product Marking**

8.1 Each shipping unit shall bear a tag or be plainly marked with the following: ASTM designation number, name or trademark of manufacturer, number of pieces, and purchase order number.

**9. Keywords**

9.1 dial pressure gages; dial thermometers; modular gage boards; pressure gages

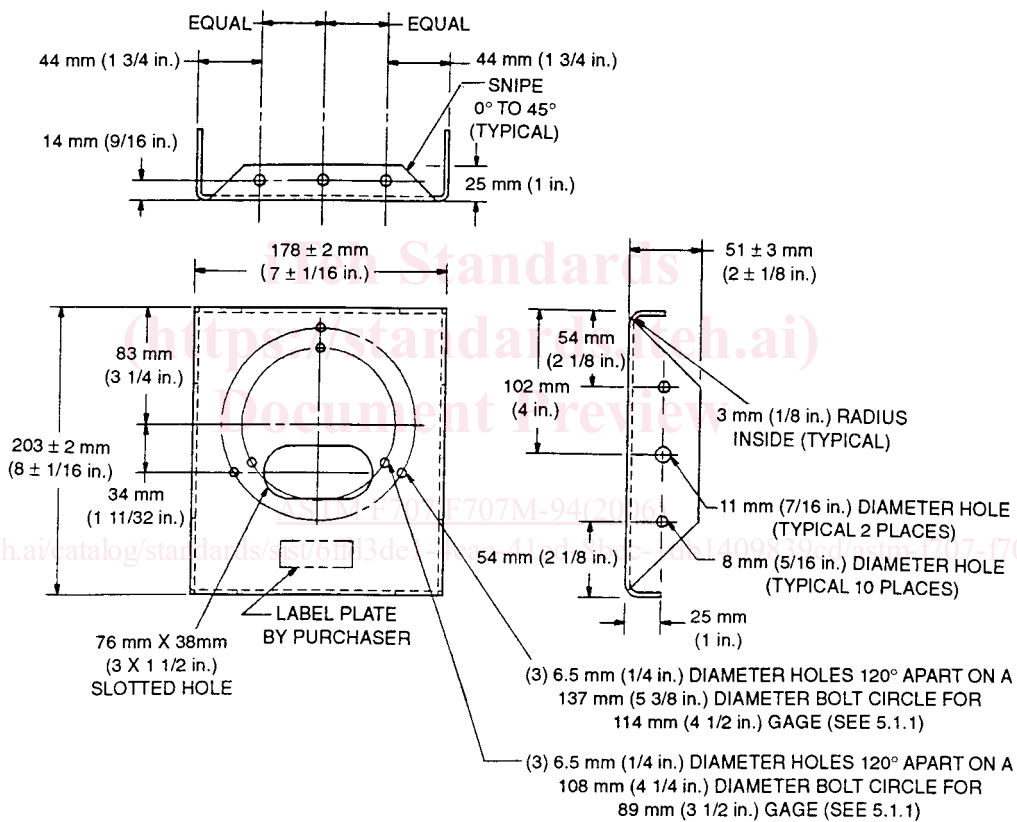

FIG. 1 Gage Board Type I