



Designation: D6744 – 06

Standard Test Method for Determination of the Thermal Conductivity of Anode Carbons by the Guarded Heat Flow Meter Technique¹

This standard is issued under the fixed designation D6744; the number immediately following the designation indicates the year of original adoption or, in the case of revision, the year of last revision. A number in parentheses indicates the year of last reapproval. A superscript epsilon (ϵ) indicates an editorial change since the last revision or reapproval.

1. Scope

1.1 This test method covers a steady-state technique for the determination of the thermal conductivity of carbon materials in thicknesses of less than 25 mm. The test method is useful for homogeneous materials having a thermal conductivity in the approximate range $1 < \lambda < 30$ W/(m·K), (thermal resistance in the range from 10 to 400×10^{-4} m²·K/W) over the approximate temperature range from 150 to 600 K. It can be used outside these ranges with reduced accuracy for thicker specimens and for thermal conductivity values up to 60 W/(m·K).

NOTE 1—It is not recommended to test graphite cathode materials using this test method. Graphites usually have a very low thermal resistance, and the interfaces between the sample to be tested and the instrument become more significant than the sample itself.

1.2 This test method is similar in concept to Test Methods E1530 and C518. Significant attention has been paid to ensure that the thermal resistance of contacting surfaces is minimized and reproducible.

1.3 The values stated in SI units are regarded as standard.

1.4 *This standard does not purport to address all of the safety concerns, if any, associated with its use. It is the responsibility of the user of this standard to establish appropriate safety and health practices and determine the applicability of regulatory limitations prior to use.*

2. Referenced Documents

2.1 ASTM Standards:²

C518 Test Method for Steady-State Thermal Transmission Properties by Means of the Heat Flow Meter Apparatus

¹ This test method is under the jurisdiction of ASTM Committee D02 on Petroleum Products and Lubricants and is the direct responsibility of Subcommittee D02.05 on Properties of Fuels, Petroleum Coke and Carbon Material.

Current edition approved Jan. 1, 2006. Published February 2006. Originally approved in 2001. Last previous edition in 2001 as D6744-01. DOI: 10.1520/D6744-06.

² For referenced ASTM standards, visit the ASTM website, www.astm.org, or contact ASTM Customer Service at service@astm.org. For *Annual Book of ASTM Standards* volume information, refer to the standard's Document Summary page on the ASTM website.

E1530 Test Method for Evaluating the Resistance to Thermal Transmission of Materials by the Guarded Heat Flow Meter Technique

3. Terminology

3.1 Definitions of Terms Specific to This Standard:

3.1.1 *average temperature*—the average temperature of a surface is the area-weighted mean temperature of that surface.

3.1.2 *heat flux transducer (HFT)*—a device that produces an electrical output that is a function of the heat flux, in a predefined and reproducible manner.

3.1.3 *thermal conductance (C)*—the time rate of heat flux through a unit area of a body induced by unit temperature difference between the body surfaces.

3.1.4 *thermal conductivity (λ), of a solid material*—the time rate of heat flow, under steady conditions, through unit area, per unit temperature gradient in the direction perpendicular to the area.

3.1.5 *thermal resistance (R)*—the reciprocal of thermal conductance.

3.2 Symbols:

- λ = thermal conductivity, W/(m·K), Btu·in/(h·ft²·°F)
- C = thermal conductance, W/(m²·K), Btu/(h·ft²·°F)
- R = thermal resistance, m²·K/W, h·ft²·°F/Btu
- Δx = specimen thickness, mm, in
- A = specimen cross sectional area, m², ft²
- Q = heat flow, W, Btu/h
- ϕ = heat flux transducer output, mV
- N = heat flux transducer calibration constant, W/(m²·mV), Btu/(h·ft²·mV)
- $N\phi$ = heat flux, W/m², Btu/(h·ft²)
- ΔT = temperature difference, °C, °F
- T_g = temperature of guard heater, °C, °F
- T_u^s = temperature of upper heater, °C, °F
- T_l = temperature of lower heater, °C, °F
- T_1 = temperature of one surface of the specimen, °C, °F
- T_2 = temperature of the other surface of the specimen, °C, °F
- T_m = mean temperature of the specimen, °C, °F

- s = unknown specimen
- r = known calibration or reference specimen
- o = contacts

4. Summary of Test Method

4.1 A specimen and a heat flux transducer (HFT) are sandwiched between two flat plates controlled at different temperatures, to produce a heat flow through the test stack. A reproducible load is applied to the test stack by pneumatic or hydraulic means, to ensure that there is a reproducible contact resistance between the specimen and plate surfaces. A cylindrical guard surrounds the test stack and is maintained at a uniform mean temperature of the two plates, in order to minimize lateral heat flow to and from the stack. At steady-state, the difference in temperature between the surfaces contacting the specimen is measured with temperature sensors embedded in the surfaces, together with the electrical output of the HFT. This output (voltage) is proportional to the heat flow through the specimen, the HFT and the interfaces between the specimen and the apparatus. The proportionality is obtained through prior calibration of the system with specimens of known thermal resistance measured under the same conditions, such that contact resistance at the surface is made reproducible.

5. Significance and Use

5.1 This test method is designed to measure and compare thermal properties of materials under controlled conditions and their ability to maintain required thermal conductance levels.

6. Apparatus

6.1 A schematic rendering of a typical apparatus is shown in Fig. 1. The relative position of the HFT to sample is not

important (it may be on the hot or cold side) as the test method is based on maintaining axial heat flow with minimal heat losses or gains radially. It is also up to the designer whether to choose heat flow upward or downward or horizontally, although downward heat flow in a vertical stack is the most common one.

6.2 Key Components of a Typical Device:

6.2.1 The compressive force for the stack is to be provided by either a regulated pneumatic or hydraulic cylinder (1) or a spring loaded mechanism. In either case, means must be provided to ensure that the loading can be varied and set to certain values reproducibility.

6.2.2 The loading force must be transmitted to the stack through a gimball joint (2) that allows up to 5° swivel in the plane perpendicular to the axis of the stack.

6.2.3 Suitable insulator plate (3) separates the gimball joint from the top plate (4).

6.2.4 The top plate (assumed to be the hot plate for the purposes of this description) is equipped with a heater (5) and control thermocouple (6) adjacent to the heater, to maintain a certain desired temperature. (Other means of producing and maintaining temperature may also be used as long as the requirements under 6.3 are met.) The construction of the top plate is such as to ensure uniform heat distribution across its face contacting the sample (8). Attached to this face (or embedded in close proximity to it), in a fashion that does not interfere with the sample/plate interface, is a temperature sensor (7) (typically a thermocouple, thermistor) that defines the temperature of the interface on the plate side.

6.2.5 The sample (8) is in direct contact with the top plate on one side and an intermediate plate (9) on the other side.

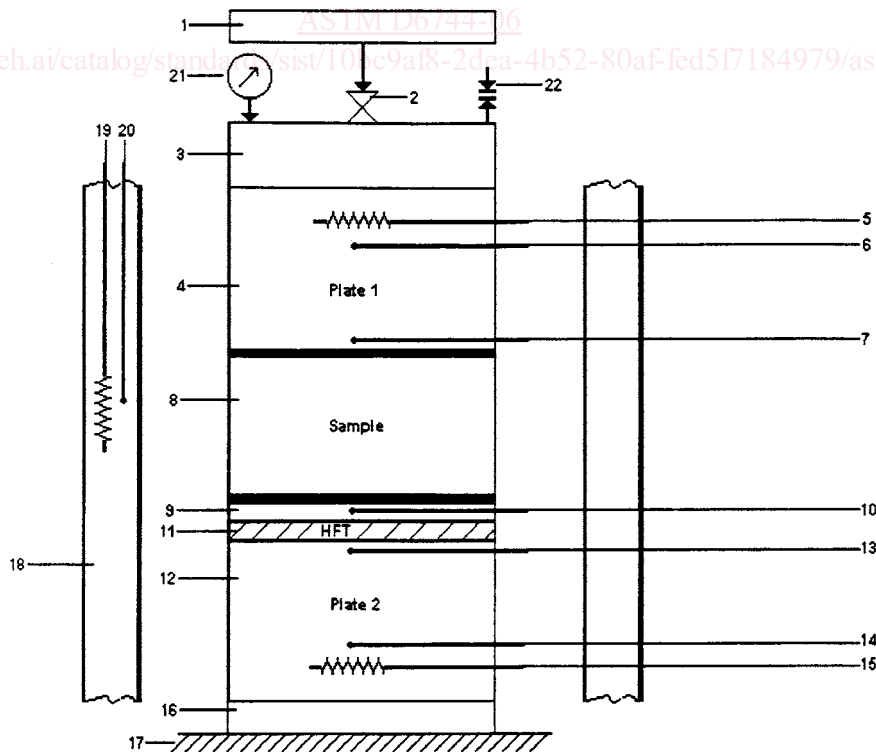

FIG. 1 Key Components of a Typical Device

6.2.6 The intermediate plate (9) is an optional item. Its purpose is to provide a highly conductive environment to the second temperature sensor (10), to obtain an average temperature of the surface. If the temperature sensor (10) is embedded into the face of the HFT, or other means are provided to define the temperature of the surface facing the sample, the use of the intermediate plate is not mandatory.

6.2.7 Heat flux transducer (HFT) is a device that will generate an electrical signal in proportion to the heat flux across it. The level of output required (sensitivity) greatly depends on the rest of the instrumentation used to read it. The overall performance of the HFT and its readout instrumentation shall be such as to meet the requirements in Section 13.

6.2.8 The lower plate (12) is constructed similarly to the upper plate (4), except it is positioned as a mirror image.

6.2.9 An insulator plate (16) separates the lower plate (12) from the heat sink (17). In case of using circulating fluid in place of a heater/thermocouple arrangement in the upper and/or lower plates, the heat sink may or may not be present.

6.2.10 The entire stack is surrounded by a cylindrical guard (18) equipped with a heater (19) and a control thermocouple (20) to maintain it at the mean temperature between the upper and lower plates. A small, generally unfilled gap separates the guard from the stack. For instruments limited to operate in the ambient region, no guard is required. A draft shield is recommended in place of it.

NOTE 2—It is permissible to use thin layers of high conductivity grease or elastomeric material on the two surfaces of the sample to reduce the thermal resistance of the interface and promote uniform thermal contact across the interface area.

NOTE 3—The cross sectional area of the sample may be any, however, most commonly circular and rectangular cross sections are used. Minimum size is dictated by the magnitude of the disturbance caused by thermal sensors in relation to the overall flux distribution. The most common sizes are 25 mm round or square to 50 mm round.

6.3 Requirements:

6.3.1 Temperature control of upper and lower plate is to be ± 0.1 °C (± 0.18 °F) or better.

6.3.2 Reproducible load of 0.28 MPa (40 psi) has been found to be satisfactory for solid samples. Minimum load shall not be below 0.07 MPa (10 psi).

6.3.3 Temperature sensors are usually fine gage or small diameter sheath thermocouples, however, ultraminiature resistance thermometers and linear thermistors may also be used.

6.3.4 Operating range of a device using a mean temperature guard shall be limited to -100 °C to 300 °C, when using thermocouples as temperature sensors, and -180 °C to 300 °C with platinum resistance thermometers.

7. Test Specimen

7.1 The specimen to be tested shall be representative for the sample material. The recommended specimen configuration is a 50.8 ± 0.25 mm (2 ± 0.010 in.) diameter disk, having smooth flat and parallel faces, ± 0.025 mm (± 0.001 in.), such that a uniform thickness within 0.025 mm (± 0.001 in.) is attained in the range from 12.7 to 25.4 mm (0.5 to 1.0 in.)

8. Sampling and Conditioning

8.1 Cut representative test specimens from larger pieces of the sample material or body.

8.2 Condition the cut specimens in accordance with the requirements of the appropriate material specifications, if any.

9. Calibration

9.1 Select the mean temperature and load conditions required. Adjust the upper heater temperature (T_u) and lower heater temperature (T_l) such that the temperature difference at the required mean temperature is no less than 30 to 35 °C and the specimen ΔT is not less than 3 °C. Adjust the guard heater temperature (T_g) such that it is at approximately the average of T_u and T_l .

9.2 Select at least two calibration specimens having thermal resistance values that bracket the range expected for the test specimens at the temperature conditions required.

9.3 Table 1 contains a list of several available materials commonly used for calibration, together with corresponding thermal resistance (R_s) values for a given thickness. This information is provided to assist the user in selecting optimum specimen thickness for testing a material and in deciding which calibration specimens to use.

9.4 The range of thermal conductivity for which this test method is most suitable is such that the optimum thermal resistance range is from 10×10^{-4} to 400×10^{-4} m²·K/W. The most commonly used calibration materials are the Pyrex 7740, Pyroceram 9606, and stainless steel.

9.5 Measure the thickness of the specimen to 25 μ m.

9.6 Coat both surfaces of a calibration specimen with a very thin layer of a compatible heat sink compound or place a thin layer of elastomeric heat transfer medium on it to help minimize the thermal resistance at the interfaces of adjacent contacting surfaces.

9.7 Insert the calibration specimen into the test chamber. Exercise care to ensure that all surfaces are free of any foreign matter.

9.8 Close the test chamber and clamp the calibration specimen in position between the plates at the recommended compressive load of 0.28 MPa.

9.9 Wait for thermal equilibrium to be attained. This should be seen when all the temperatures measured do not drift more

TABLE 1 Typical Thermal Resistance Values of Specimens of Different Materials

Material	Approximate Thermal Conductivity, W/(m·K) at 30°C	Thickness, mm	Approximate Thermal Resistance, 10^{-4} m ² ·K/W at 30 °C
Pyroceram 9606 ^A	4	20	50
Pyroceram 9606 ^A	4	10	25
Pyrex 7740 ^A Glass	1	20	200
Pyrex 7740 ^A Glass	1	10	100
Pyrex 7740 ^A Glass	1	1	10
304 Stainless Steel	14	20	14
304 Stainless Steel	14	10	7
Vespe ^B	0.4	2	50

^A Pyrex 7740 and Pyroceram 9606 are products and trademarks of Corning Glass Co., Corning, WV.

^B Vespe^B is a product of DuPont Co.