**Rubber, vulcanized or thermoplastic —
Determination of adhesion to metal —
Two-plate method**

*Caoutchouc vulcanisé — Détermination de l'adhérence au métal —
Méthode à deux plaques*

iTeh STANDARD PREVIEW
(standards.iteh.ai)

[ISO 814:2007](#)

<https://standards.iteh.ai/catalog/standards/sist/1a2b4052-db55-434d-9693-8fe264ebad49/iso-814-2007>



PDF disclaimer

This PDF file may contain embedded typefaces. In accordance with Adobe's licensing policy, this file may be printed or viewed but shall not be edited unless the typefaces which are embedded are licensed to and installed on the computer performing the editing. In downloading this file, parties accept therein the responsibility of not infringing Adobe's licensing policy. The ISO Central Secretariat accepts no liability in this area.

Adobe is a trademark of Adobe Systems Incorporated.

Details of the software products used to create this PDF file can be found in the General Info relative to the file; the PDF-creation parameters were optimized for printing. Every care has been taken to ensure that the file is suitable for use by ISO member bodies. In the unlikely event that a problem relating to it is found, please inform the Central Secretariat at the address given below.

iTeh STANDARD PREVIEW
(standards.iteh.ai)

ISO 814:2007

<https://standards.iteh.ai/catalog/standards/sist/1a2b4052-db55-434d-9693-8fe264ebad49/iso-814-2007>



COPYRIGHT PROTECTED DOCUMENT

© ISO 2007

All rights reserved. Unless otherwise specified, no part of this publication may be reproduced or utilized in any form or by any means, electronic or mechanical, including photocopying and microfilm, without permission in writing from either ISO at the address below or ISO's member body in the country of the requester.

ISO copyright office
Case postale 56 • CH-1211 Geneva 20
Tel. + 41 22 749 01 11
Fax + 41 22 749 09 47
E-mail copyright@iso.org
Web www.iso.org

Published in Switzerland

Contents

Page

Foreword.....	iv
1 Scope	1
2 Normative references	1
3 Principle	1
4 Apparatus	2
5 Test piece	2
5.1 Dimensions.....	2
5.2 Preparation	2
5.3 Number	2
5.4 Conditioning.....	4
6 Procedure	4
7 Expression of results	4
7.1 Adhesion value	4
7.2 Adhesion failure symbols	4
8 Test report	5

iTeh STANDARD PREVIEW
(standards.iteh.ai)

ISO 814:2007

<https://standards.iteh.ai/catalog/standards/sist/1a2b4052-db55-434d-9693-8fe264ebad49/iso-814-2007>

Foreword

ISO (the International Organization for Standardization) is a worldwide federation of national standards bodies (ISO member bodies). The work of preparing International Standards is normally carried out through ISO technical committees. Each member body interested in a subject for which a technical committee has been established has the right to be represented on that committee. International organizations, governmental and non-governmental, in liaison with ISO, also take part in the work. ISO collaborates closely with the International Electrotechnical Commission (IEC) on all matters of electrotechnical standardization.

International Standards are drafted in accordance with the rules given in the ISO/IEC Directives, Part 2.

The main task of technical committees is to prepare International Standards. Draft International Standards adopted by the technical committees are circulated to the member bodies for voting. Publication as an International Standard requires approval by at least 75 % of the member bodies casting a vote.

Attention is drawn to the possibility that some of the elements of this document may be the subject of patent rights. ISO shall not be held responsible for identifying any or all such patent rights.

ISO 814 was prepared by Technical Committee ISO/TC 45, *Rubber and rubber products*, Subcommittee SC 2, *Testing and analysis*.

This fourth edition cancels and replaces the third edition (ISO 814:1996), which has been revised principally to update the normative references (ISO 471 and ISO 4648 have been replaced by ISO 23529). The text has also been clarified by replacing “may” with “can”. Since ISO 5893 has also been revised, the force-measuring accuracy of the tensile-testing machine has been corrected to class 2. In addition, in Clause 8, the layout of the test report has been updated. Finally, it has been made clear in the title that the standard is also applicable to thermoplastic rubber.

iTeh STANDARD PREVIEW
(standards.iteh.ai)
ISO 814:2007
<https://standards.iteh.ai/catalog/standards/sist/1a2b4052-db55-434d-9693-8fe264ebad49/iso-814-2007>

Rubber, vulcanized or thermoplastic — Determination of adhesion to metal — Two-plate method

WARNING — Persons using this International Standard should be familiar with normal laboratory practice. This standard does not purport to address all of the safety problems, if any, associated with its use. It is the responsibility of the user to establish appropriate safety and health practices and to ensure compliance with any national regulatory conditions.

CAUTION — Certain procedures specified in this International Standard may involve the use or generation of substances, or the generation of waste, that could constitute a local environmental hazard. Reference should be made to appropriate documentation on safe handling and disposal after use.

1 Scope

This International Standard specifies a method for determining the adhesion strength of rubber-to-metal bonds where the rubber part is assembled between two parallel metal plates, using the adhesive system under investigation.

The method is applicable primarily to test pieces, prepared in the laboratory under standard conditions, such as can be used to provide data for the development of rubber compounds and control of methods of manufacture.

<https://standards.iteh.ai/catalog/standards/sist/1a2b4052-db55-434d-9693-8fe264ebad49/iso-814-2007>

2 Normative references

The following referenced documents are indispensable for the application of this document. For dated references, only the edition cited applies. For undated references, the latest edition of the referenced document (including any amendments) applies.

ISO 5893, *Rubber and plastics test equipment — Tensile, flexural and compression types (constant rate of traverse) — Specification*

ISO 23529:2004, *Rubber — General procedures for preparing and conditioning test pieces for physical test methods*

3 Principle

The test consists in measuring the force required to cause the rupture of a unit of standard dimensions, comprising rubber bonded to two parallel metal plates, the direction of the force being at 90° to the bonded surface.

4 Apparatus

4.1 Tensile-testing machine, complying with the requirements of ISO 5893, capable of measuring force with an accuracy corresponding to class 2 as defined in ISO 5893, and with a rate of traverse of the moving grip of 25 mm/min \pm 5 mm/min.

NOTE Inertia (pendulum) type dynamometers are apt to give results which differ because of frictional and inertial effects. An inertialess (for example, electronic or optical transducer) type dynamometer gives results which are free from these effects and is therefore preferred.

4.2 Fixtures, for holding the test pieces in the test machine (4.1), which permit accurate centring of the applied load during the test.

A suitable type of fixture is shown in Figure 1.

5 Test piece

5.1 Dimensions

The standard test piece shall consist of a rubber cylinder 3 mm \pm 0,1 mm thick and of diameter between 35 mm and 40 mm known to the nearest 0,1 mm, having its circular ends bonded to the faces of two metal plates of equal diameter, the determination of dimensions of the test piece being in accordance with ISO 23529. The diameter of the metal plates shall be approximately 0,1 mm less than that of the rubber cylinder. The thickness of the metal plates shall be not less than 9 mm. A typical test piece is shown in Figure 2.

5.2 Preparation

5.2.1 Circular metal plates of the standard dimensions shall be prepared preferably from rolled carbon steel bar. Other metals can be used provided that the parts are in conformity with the essential dimensions. The smooth metal parts shall be prepared and treated in accordance with the adhesion system under investigation.

5.2.2 Rubber discs shall be cut using a circular die of such size that a limited amount of flash is obtained on moulding. The surface of the rubber to be bonded to the metal shall be treated in accordance with the method being investigated.

5.2.3 The rubber discs and metal end pieces shall then be assembled for moulding in the mould. The mould shall be constructed so that the rubber projects beyond the edges of the metal end pieces by approximately 0,05 mm in order to prevent tearing of the rubber by the edge of the metal during testing.

5.2.4 During the preparation of the test piece, great care shall be taken to keep the exposed surfaces of the rubber and metal free from dust, moisture and other foreign matter. The surfaces shall not be touched by hand during assembly.

5.2.5 Moulding shall then be carried out by heating in the mould under pressure for a definite time at a controlled temperature in a suitable press. The time and temperature of moulding shall be in accordance with the system being investigated.

5.2.6 At the conclusion of the cure, great care shall be taken in removing the test pieces from the mould to avoid subjecting the bonded surfaces to undue stress before the test pieces have cooled.

5.3 Number

At least three test pieces shall be tested.

Dimensions in millimetres

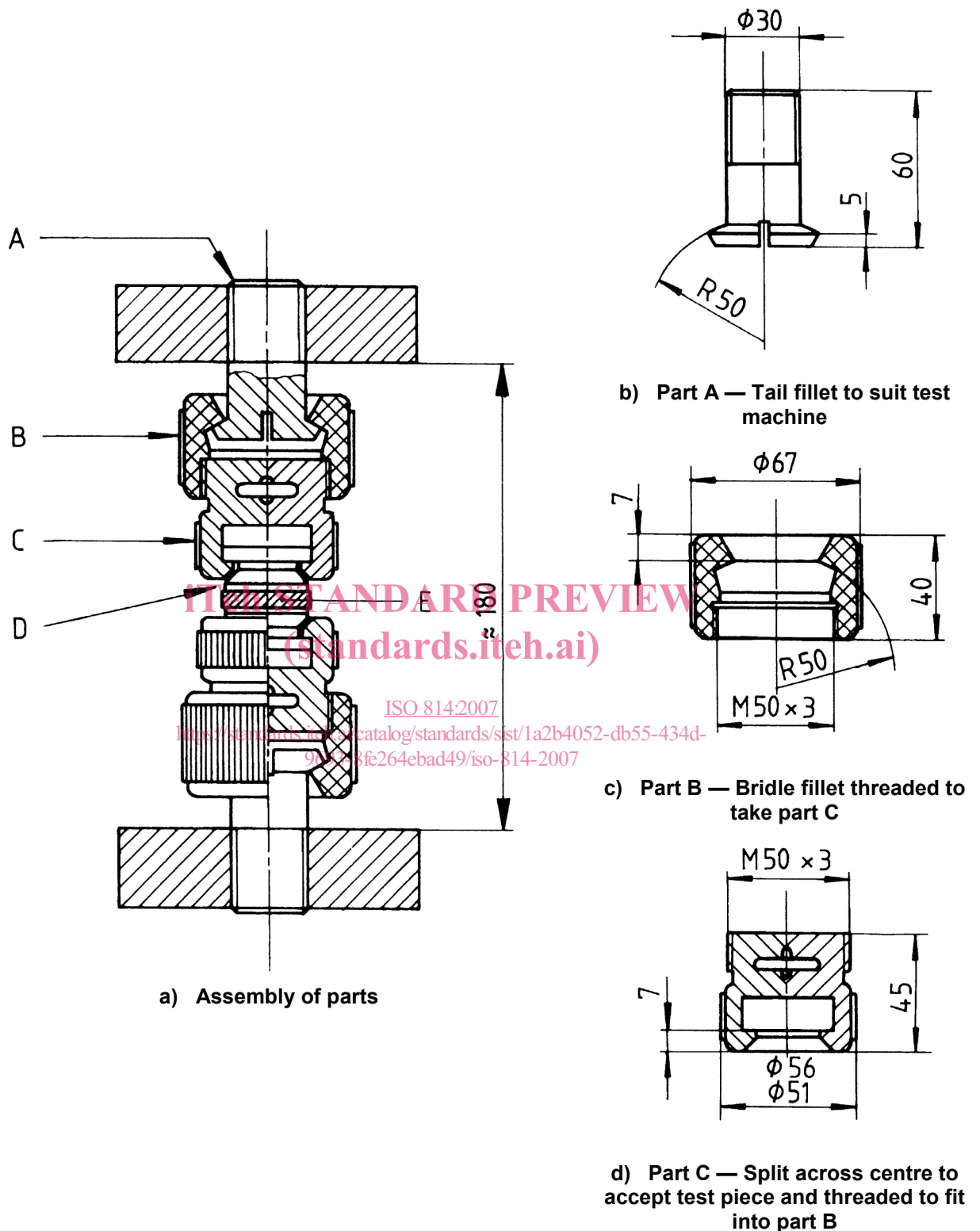
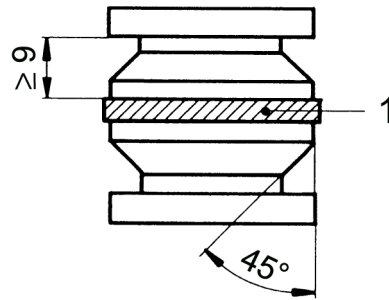

Figure 1 — Example of test fixture for holding rubber-to-metal bond test pieces

**Key**

1 test piece

Figure 2 — Example of standard test piece**5.4 Conditioning**

5.4.1 The test pieces shall be conditioned in accordance with the requirements of ISO 23529 for at least 16 h at a standard laboratory temperature ($23\text{ °C} \pm 2\text{ °C}$ or $27\text{ °C} \pm 2\text{ °C}$) immediately before test, the same temperature being used throughout any one test or series of tests intended to be comparable.

5.4.2 The time-interval between vulcanization and testing shall be in accordance with the requirements of ISO 23529.

iTech STANDARD PREVIEW
(standards.iteh.ai)

6 Procedure

ISO 814:2007

[https://standards.iteh.ai/catalog/standards/sist/1a2b4052-db55-434d-](https://standards.iteh.ai/catalog/standards/sist/1a2b4052-db55-434d-2593-662547bed49f/iso-814-2007)

6.1 Mount the test piece in the fixtures (4.2) in the test machine (4.1). Extreme care is necessary in centring and adjusting the test piece so that the tension is uniformly distributed over the cross-section during the test.

6.2 Apply tension by separating the jaws at a constant rate of $25\text{ mm/min} \pm 5\text{ mm/min}$ until the test piece breaks. Record the maximum force.

7 Expression of results**7.1 Adhesion value**

The adhesion shall be calculated by dividing the maximum force by the cross-sectional area of the test piece. It shall be expressed in pascals.

7.2 Adhesion failure symbols

- a) R indicates that the failure is in the rubber.
- b) RC indicates that the failure is at the interface between the rubber and the cover cement.
- c) CP indicates that the failure is at the interface between the cover cement and the prime cement.
- d) M indicates that the failure is at the interface between the metal and the prime cement.

8 Test report

The test report shall include at least the following information:

- a) a reference to this International Standard;
- b) details of test piece:
 - 1) the time and temperature of vulcanization,
 - 2) the date of vulcanization,
 - 3) the metal used, if other than the steel specified;
- c) test details:
 - 1) the time and temperature of conditioning prior to test,
 - 2) the temperature of the test,
 - 3) any unusual features noted during the determination,
 - 4) the number of test pieces tested,
 - 5) any operation not included in this International Standard or in the International Standards to which reference is made, as well as any operation regarded as optional;
- d) test results:
 - 1) the test result for each test piece, expressed in accordance with 7.1,
<https://standards.iteh.ai/catalog/standards/sist/1a2b4052-db55-434d-933e-4a4a4a4a4a4a>
 - 2) a description of the type (or types) of failure, expressed in accordance with 7.2, indicating the percentage failure of each type which occurs;
- e) the date of the test.