

---

---

**Rubber and plastics inlet hoses and hose  
assemblies for washing-machines and  
dishwashers — Specification**

*Tuyaux et flexibles en caoutchouc et en plastique pour l'alimentation  
des machines à laver et lave-vaisselle — Spécifications*

**iTeh STANDARD PREVIEW**  
**(standards.iteh.ai)**

[ISO 6804:2009](#)

[https://standards.iteh.ai/catalog/standards/sist/630e1680-34b1-4961-  
b01b-b5ed01c93ddd/iso-6804-2009](https://standards.iteh.ai/catalog/standards/sist/630e1680-34b1-4961-b01b-b5ed01c93ddd/iso-6804-2009)



**PDF disclaimer**

This PDF file may contain embedded typefaces. In accordance with Adobe's licensing policy, this file may be printed or viewed but shall not be edited unless the typefaces which are embedded are licensed to and installed on the computer performing the editing. In downloading this file, parties accept therein the responsibility of not infringing Adobe's licensing policy. The ISO Central Secretariat accepts no liability in this area.

Adobe is a trademark of Adobe Systems Incorporated.

Details of the software products used to create this PDF file can be found in the General Info relative to the file; the PDF-creation parameters were optimized for printing. Every care has been taken to ensure that the file is suitable for use by ISO member bodies. In the unlikely event that a problem relating to it is found, please inform the Central Secretariat at the address given below.

**iTeh STANDARD PREVIEW**  
**(standards.iteh.ai)**

ISO 6804:2009

<https://standards.iteh.ai/catalog/standards/sist/630e1680-34b1-4961-b01b-b5ed01c93ddd/iso-6804-2009>



**COPYRIGHT PROTECTED DOCUMENT**

© ISO 2009

All rights reserved. Unless otherwise specified, no part of this publication may be reproduced or utilized in any form or by any means, electronic or mechanical, including photocopying and microfilm, without permission in writing from either ISO at the address below or ISO's member body in the country of the requester.

ISO copyright office  
Case postale 56 • CH-1211 Geneva 20  
Tel. + 41 22 749 01 11  
Fax + 41 22 749 09 47  
E-mail [copyright@iso.org](mailto:copyright@iso.org)  
Web [www.iso.org](http://www.iso.org)

Published in Switzerland

## Contents

Page

Foreword.....	iv
1 Scope .....	1
2 Normative references .....	1
3 Terms and definitions.....	2
4 Classification.....	2
5 Couplings and fittings .....	2
6 Materials and construction .....	2
7 Dimensions and tolerances .....	3
8 Performance requirements for finished hoses .....	3
9 Frequency of testing.....	9
10 Test certificate.....	9
11 Marking .....	9
12 Recommendations for packaging and storage .....	9
Annex A (normative) Type tests and routine tests .....	10
Annex B (informative) Recommended tests for production testing .....	11
Annex C (informative) Delivery certificate and test certificate .....	12
Bibliography .....	13

## Foreword

ISO (the International Organization for Standardization) is a worldwide federation of national standards bodies (ISO member bodies). The work of preparing International Standards is normally carried out through ISO technical committees. Each member body interested in a subject for which a technical committee has been established has the right to be represented on that committee. International organizations, governmental and non-governmental, in liaison with ISO, also take part in the work. ISO collaborates closely with the International Electrotechnical Commission (IEC) on all matters of electrotechnical standardization.

International Standards are drafted in accordance with the rules given in the ISO/IEC Directives, Part 2.

The main task of technical committees is to prepare International Standards. Draft International Standards adopted by the technical committees are circulated to the member bodies for voting. Publication as an International Standard requires approval by at least 75 % of the member bodies casting a vote.

Attention is drawn to the possibility that some of the elements of this document may be the subject of patent rights. ISO shall not be held responsible for identifying any or all such patent rights.

ISO 6804 was prepared by Technical Committee ISO/TC 45, *Rubber and rubber products*, Subcommittee SC 1, *Hoses (rubber and plastics)*.

This third edition cancels and replaces the second edition (ISO 6804:1991), which has been technically revised as follows:

- plastics hoses have been added as type 3 in Clause 1;
- requirements for plastics hoses and the corresponding tests, such as the flexing tests in 8.2, have been added.

iTeh STANDARD PREVIEW  
(standards.iteh.ai)

ISO 6804:2009

<https://standards.iteh.ai/catalog/standards/sist/630e1680-34b1-4961-b01b-b5ed01c93ddd/iso-6804-2009>

# Rubber and plastics inlet hoses and hose assemblies for washing-machines and dishwashers — Specification

## 1 Scope

This International Standard specifies the requirements for three types of rubber or plastics inlet hoses and hose assemblies for washing-machines and dishwashers connected to the domestic water supply at a pressure not exceeding 1 MPa (10 bar).

It is applicable to the following types of hose:

- Type 1: rubber hoses for unheated water supply (maximum temperature 70 °C).
- Type 2: rubber hoses for heated water supply (maximum temperature 90 °C).
- Type 3: plastics hoses for unheated water supply (maximum temperature 60 °C).

There may be national requirements for hose fittings and hoses conveying drinking water which must be complied with.

## 2 Normative references

[ISO 6804:2009](#)

<http://standards.iteh.ai/catalog/standards/sist/630e1680-34b1-4961-b01b-b5ed01c93ddd/iso-6804-2009>

The following referenced documents are indispensable for the application of this document. For dated references, only the edition cited applies. For undated references, the latest edition of the referenced document (including any amendments) applies.

ISO 188, *Rubber, vulcanized or thermoplastic — Accelerated ageing and heat resistance tests*

ISO 1307, *Rubber and plastics hoses — Hose sizes, minimum and maximum inside diameters, and tolerances on cut-to-length hoses*

ISO 1402, *Rubber and plastics hoses and hose assemblies — Hydrostatic testing*

ISO 1746:1998, *Rubber or plastics hoses and tubing — Bending tests*

ISO 4671, *Rubber and plastics hoses and hose assemblies — Methods of measurement of the dimensions of hoses and the lengths of hose assemblies*

ISO 4892-1, *Plastics — Methods of exposure to laboratory light sources — Part 1: General guidance*

ISO 4892-2, *Plastics — Methods of exposure to laboratory light sources — Part 2: Xenon-arc lamps*

ISO 4892-3, *Plastics — Methods of exposure to laboratory light sources — Part 3: Fluorescent UV lamps*

ISO 4892-4, *Plastics — Methods of exposure to laboratory light sources — Part 4: Open-flame carbon-arc lamps*

ISO 7326:2006, *Rubber and plastics hoses — Assessment of ozone resistance under static conditions*

ISO 8033, *Rubber and plastics hoses — Determination of adhesion between components*

ISO 8330, *Rubber and plastics hoses and hose assemblies — Vocabulary*

ISO 8331, *Rubber and plastics hoses and hose assemblies — Guidelines for selection, storage, use and maintenance*

ISO 23529, *Rubber — General procedures for preparing and conditioning test pieces for physical test methods*

### 3 Terms and definitions

For the purposes of this document, the terms and definitions given in ISO 8330 apply.

### 4 Classification

Hoses are designated as one of the following three types, depending on the hose material and the temperature of the water supply:

- Type 1:** Rubber hoses for a medium-temperature water supply (up to 70 °C) — for a maximum working pressure of 1 MPa (10 bar).
- Type 2:** Rubber hoses for a high-temperature water supply (up to 90 °C) — for a maximum working pressure of 1 MPa (10 bar).
- Type 3:** Plastics hoses for low temperature (up to 60 °C) water supply — for a maximum working pressure of 0,8 MPa (8 bar).

[ISO 6804:2009](https://standards.iteh.ai/catalog/standards/sist/630e1680-34b1-4961-b01b-b5ed01c93ddd/iso-6804-2009)

<https://standards.iteh.ai/catalog/standards/sist/630e1680-34b1-4961-b01b-b5ed01c93ddd/iso-6804-2009>

### 5 Couplings and fittings

Hoses may be fitted with the appropriate type of coupling and end fitting to form hose assemblies.

NOTE Guidance on coupling types is given in ISO/TR 17784.

### 6 Materials and construction

The hose construction shall be as follows:

- a) the hose lining shall consist of rubber for type 1 and type 2 or thermoplastics material for type 3;
- b) the hose reinforcement shall consist of natural or synthetic textile material applied by any suitable technique;
- c) the hose cover shall consist of an ozone-resistant rubber for type 1 and type 2 or a weather-resistant thermoplastics material for type 3 (or, alternatively, a stainless-steel braid may be used instead of a cover).

The lining and the cover shall be of uniform thickness, concentric, fully gelled and free from visible cracks, porosity, foreign inclusions and other defects which could cause the hose to be unserviceable.

## 7 Dimensions and tolerances

### 7.1 Inside diameters, tolerances and minimum wall thickness

#### 7.1.1 Type 1 and type 2 hoses

The preferred values for the bore of the hose are 10 mm and 12,5 mm.

The tolerances on the bore will depend on the characteristics of the end fittings; consequently, they shall be agreed between the manufacturer of the hose and the constructor of the hose assembly, but shall not exceed the maximum tolerances specified in ISO 1307.

#### 7.1.2 Type 3 hoses

When measured in accordance with ISO 4671, the inside diameter and minimum wall thickness of the hose shall meet the requirements specified in Table 1.

**Table 1 — Nominal bores, inside diameters, tolerances on inside diameter and minimum wall thicknesses of plastics hoses**

Nominal bore	Inside diameter mm	Tolerances on inside diameter mm	Minimum wall thickness mm
10	10	$\pm 0,6$	2,6
13	12,7	$\pm 0,6$	2,6

ISO 6804:2009

### 7.2 Concentricity <https://standards.iteh.ai/catalog/standards/sist/630e1680-34b1-4961-b01b-b5ed01c93ddd/iso-6804-2009>

When determined in accordance with ISO 4671, the concentricity, based on a total indicator reading between the inside diameter and the outside surface of the cover, shall be no greater than 0,3 mm.

### 7.3 Tolerances on length

The tolerances on cut lengths of hose shall be in accordance with ISO 1307.

## 8 Performance requirements for finished hoses

### 8.1 Bending test

The bending test shall be carried out at a standard temperature as specified in ISO 23529.

When tested in accordance with ISO 1746:1998, method A, using a bending radius of 7,5 times the outside diameter, the hoses shall show no evidence, under visual examination, of kinking, breaking or peeling. The value of the coefficient of deformation (*TID*) shall not be lower than 0,8.

### 8.2 Flexing tests

#### 8.2.1 General

In the case of type 3 hoses, flexing tests shall be carried out using the test arrangement shown in Figure 1.

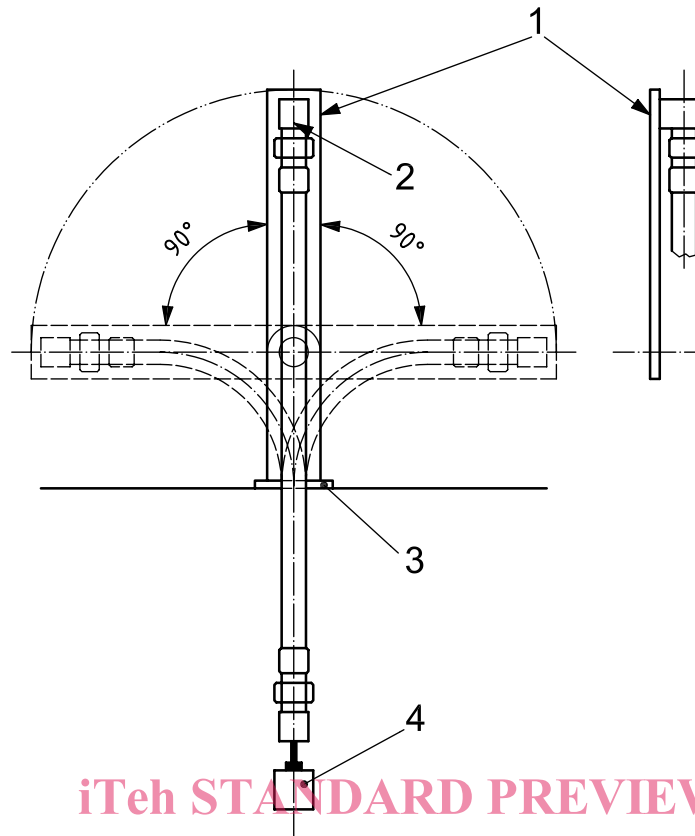

iTeh STANDARD PREVIEW  
(standards.iteh.ai)

ISO 6804:2009

<https://standards.iteh.ai/catalog/standards/sist/630e1680-34b1-4961-b01b-b5ed01c93ddd/iso-6804-2009>

**Key**

- 1 oscillating arm
- 2 flexing of coupling
- 3 support
- 4 2 kg weight

**Figure 1 — Arrangement for flexing tests**

**8.2.2 Sub-ambient temperature flexing test**

When the hose is tested during and after conditioning for 5 h at  $(-5 \pm 3) ^\circ\text{C}$ , the oscillating arm is moved right and left alternately through an angle of  $90^\circ$  at a rate of  $(50 \pm 10)$  flexings per minute for 500 flexings. The hose shall show no evidence of cracking or other defects.

**8.2.3 Standard laboratory temperature flexing test**

When tested at a standard laboratory temperature as specified in ISO 23529, moving the oscillating arm through an angle of  $180^\circ$  at a rate of  $(20 \pm 5)$  flexings per minute for 100 000 flexings, the hose shall show no evidence of cracking or other defects.

**8.3 Resistance to kinking**

The kinking test shall be carried out at a standard temperature as specified in ISO 23529.

The hose assembly is folded through an angle of  $180^\circ$  and then compressed in such a way that the total thickness is equal to twice the outer diameter of the hose, as shown in Figure 2.

The pressure is maintained for 5 s, after which the hose assembly is allowed to rest for 1 min.

The test is carried out ten times at the same point, the fold being made in the same direction each time.



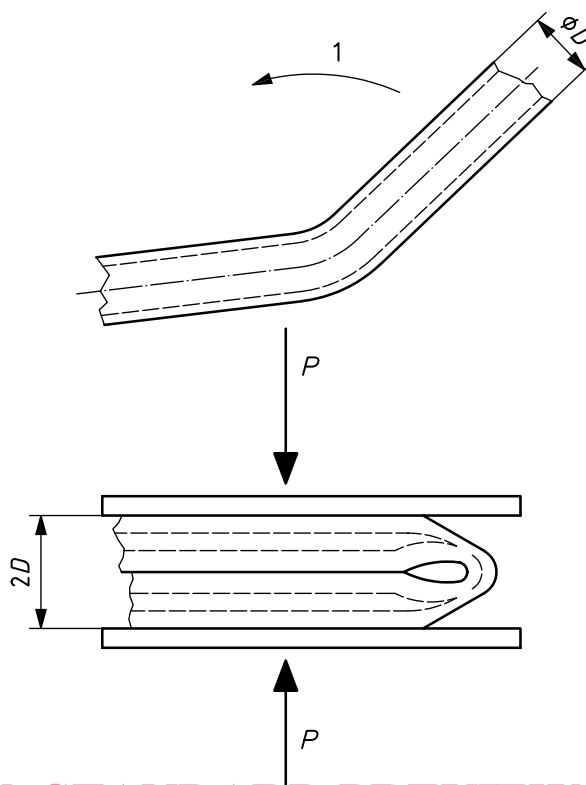

iTeh STANDARD PREVIEW  
(standards.iteh.ai)

**Key**

1 direction of fold

ISO 6804:2009

<https://standards.iteh.ai/catalog/standards/sist/630e1680-34b1-4961-b01b-b70000000000/iso-6804-2009>

**Figure 2 — Kinking test**

After the test, the hose assembly shall be filled with water at the specified temperature and then tested at a pressure of 3,15 MPa (31,5 bar) by the method specified in ISO 1402 for 1 min. The hose shall show no evidence of leakage or other defects.

#### 8.4 Resistance to hydrostatic pressure after ageing

The hose assembly, filled with water, shall be aged for seven days (168 h) in an oven, in accordance with ISO 188, at

- $(60 \pm 2)$  °C for type 3 hoses;
- $(70 \pm 2)$  °C for type 1 hoses;
- $(90 \pm 2)$  °C for type 2 hoses.

After ageing, the hose assembly shall be emptied, refilled with water at the specified temperature and again tested at a pressure of 3,15 MPa (31,5 bar) by the method specified in ISO 1402 for 1 min.

During the pressure test, the hose assembly shall not burst or show defects such as leakage or blisters, nor shall there be evidence of coupling slippage.