**Metallic powders — Determination of
apparent density and flow rate at elevated
temperatures —**

**Part 2:
Determination of flow rate at elevated
temperatures**

iTeh STANDARD PREVIEW

*Poudres métalliques — Détermination de la masse volumique
apparente et de la vitesse d'écoulement à températures élevées —*

*Partie 2: Détermination de la vitesse d'écoulement à températures
élevées*

<https://standards.iteh.ai/catalog/standards/sist/5b5db511-27a1-4484-939d-643247b0fa1f/iso-18549-2-2009>



PDF disclaimer

This PDF file may contain embedded typefaces. In accordance with Adobe's licensing policy, this file may be printed or viewed but shall not be edited unless the typefaces which are embedded are licensed to and installed on the computer performing the editing. In downloading this file, parties accept therein the responsibility of not infringing Adobe's licensing policy. The ISO Central Secretariat accepts no liability in this area.

Adobe is a trademark of Adobe Systems Incorporated.

Details of the software products used to create this PDF file can be found in the General Info relative to the file; the PDF-creation parameters were optimized for printing. Every care has been taken to ensure that the file is suitable for use by ISO member bodies. In the unlikely event that a problem relating to it is found, please inform the Central Secretariat at the address given below.

iTeh STANDARD PREVIEW
(standards.iteh.ai)

ISO 18549-2:2009

<https://standards.iteh.ai/catalog/standards/sist/5b5db511-27a1-4484-939d-643247b0fa1f/iso-18549-2-2009>



COPYRIGHT PROTECTED DOCUMENT

© ISO 2009

All rights reserved. Unless otherwise specified, no part of this publication may be reproduced or utilized in any form or by any means, electronic or mechanical, including photocopying and microfilm, without permission in writing from either ISO at the address below or ISO's member body in the country of the requester.

ISO copyright office
Case postale 56 • CH-1211 Geneva 20
Tel. + 41 22 749 01 11
Fax + 41 22 749 09 47
E-mail copyright@iso.org
Web www.iso.org

Published in Switzerland

Contents

Page

Foreword.....	iv
1 Scope	1
2 Normative references	1
3 Apparatus	1
4 Calibration of the funnel.....	3
4.1 Method A.....	3
4.2 Method B.....	4
5 Test sample	4
6 Procedure (Methods A and B)	4
7 Result	4
7.1 Method A.....	4
7.2 Method B.....	5
8 Test report	5

iTeh STANDARD PREVIEW
(standards.iteh.ai)

ISO 18549-2:2009

<https://standards.iteh.ai/catalog/standards/sist/5b5db511-27a1-4484-939d-643247b0fa1f/iso-18549-2-2009>

Foreword

ISO (the International Organization for Standardization) is a worldwide federation of national standards bodies (ISO member bodies). The work of preparing International Standards is normally carried out through ISO technical committees. Each member body interested in a subject for which a technical committee has been established has the right to be represented on that committee. International organizations, governmental and non-governmental, in liaison with ISO, also take part in the work. ISO collaborates closely with the International Electrotechnical Commission (IEC) on all matters of electrotechnical standardization.

International Standards are drafted in accordance with the rules given in the ISO/IEC Directives, Part 2.

The main task of technical committees is to prepare International Standards. Draft International Standards adopted by the technical committees are circulated to the member bodies for voting. Publication as an International Standard requires approval by at least 75 % of the member bodies casting a vote.

Attention is drawn to the possibility that some of the elements of this document may be the subject of patent rights. ISO shall not be held responsible for identifying any or all such patent rights.

ISO 18549-2 was prepared by Technical Committee ISO/TC 119, *Powder metallurgy*, Subcommittee SC 2, *Sampling and testing methods for powders (including powders for hardmetals)*.

ISO 18549 consists of the following parts, under the general title *Metallic powders — Determination of apparent density and flow rate at elevated temperatures*:

— Part 1: *Determination of apparent density at elevated temperatures*

— Part 2: *Determination of flow rate at elevated temperatures*

Metallic powders — Determination of apparent density and flow rate at elevated temperatures —

Part 2: Determination of flow rate at elevated temperatures

1 Scope

This part of ISO 18549 describes two methods for the determination of the time (flow rate) it takes for a given quantity of a heated powder mix, based on iron or steel powders and to be used for warm compaction, to pass through a funnel with a given orifice diameter.

Method A uses a funnel with an orifice of 2,5 mm and a test portion of 50 g and is, to a large extent, based on the method standardized in ISO 4490. The method can only be used for powder mixes that flow freely through the 2,5 mm orifice in the heated condition.

Method B uses a funnel with an orifice of 5 mm and a test portion with a size of 150 g.

Both methods cover a testing temperature range of 60 °C to 180 °C and either of them can be selected after agreement between the parties involved.

[ISO 18549-2:2009](https://standards.iteh.ai/catalog/standards/sist/5b5db511-27a1-4484-939d-643247b0fa1f/iso-18549-2-2009)

<https://standards.iteh.ai/catalog/standards/sist/5b5db511-27a1-4484-939d-643247b0fa1f/iso-18549-2-2009>

2 Normative references

The following referenced documents are indispensable for the application of this document. For dated references, only the edition cited applies. For undated references, the latest edition of the referenced document (including any amendments) applies.

ISO 4490:2008, *Metallic powders — Determination of flow rate by means of a calibrated funnel (Hall flowmeter)*

3 Apparatus

3.1 Thermally insulated enclosure, where the actual measurement shall take place.

3.2 Funnel with an orifice diameter of 2,5 mm (Method A) or, alternatively, a **funnel with an orifice of 5 mm (Method B)**, see Figure 1 or 2, respectively.

The funnel should be made of a non-magnetic, corrosion-resistant metallic material with sufficient wall thickness and hardness to avoid distortion and excessive wear. The inner surface of the funnel should be polished.

3.3 Stand and horizontal vibration-free base to support the funnel rigidly, e.g. as shown in Figure 3 (Methods A and B).

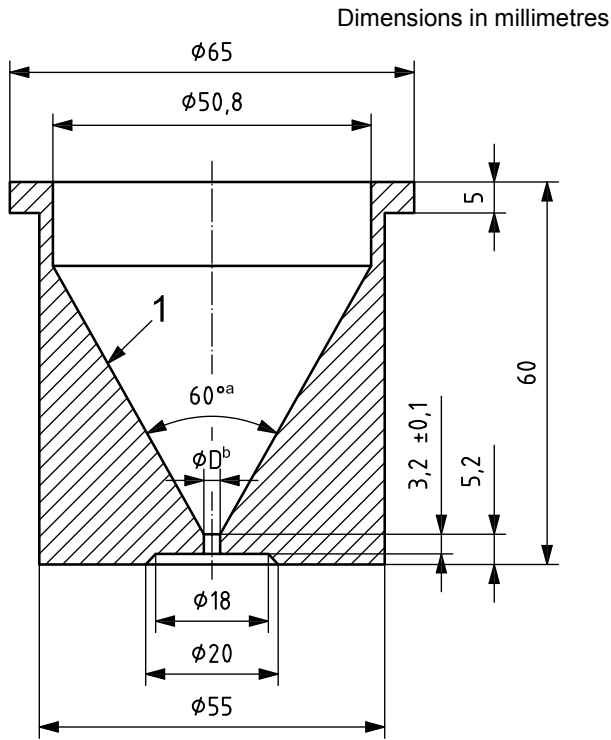

- Key**
- 1 polished to $Ra \leq 0,4 \mu\text{m}$
 - a this value is mandatory
 - b $D = 2,5_0^{+0,2}$

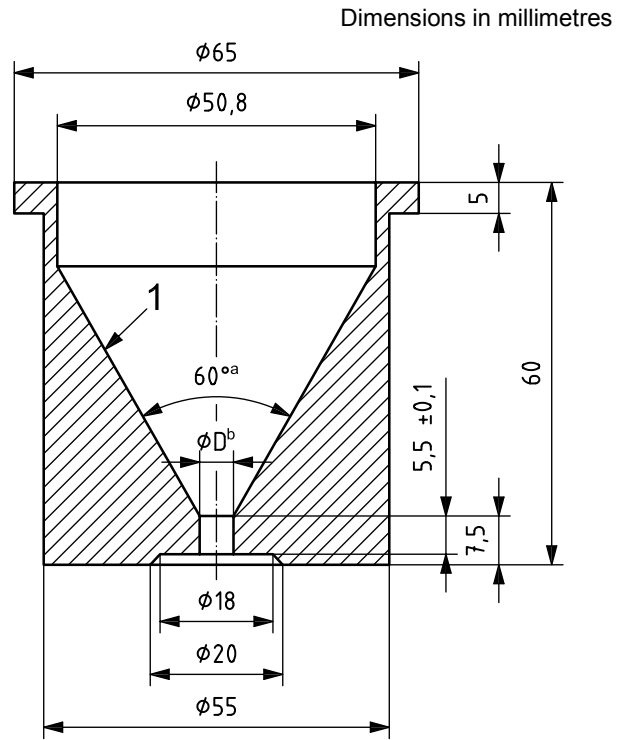

- Key**
- 1 polished to $Ra \leq 0,4 \mu\text{m}$
 - a this value is mandatory
 - b $D = 5_0^{+0,2}$

iTeh STANDARD PREVIEW
(standards.iteh.ai)

ISO 18549-2:2009
<https://standards.iteh.ai/catalog/standards/sist/5b5db511-27a1-4484-939d-643247b0fa1f/iso-18549-2-2009>

Figure 1 — Funnel with orifice diameter of 2,5 mm (Method A)

Figure 2 — Funnel with orifice diameter of 5 mm (Method B)

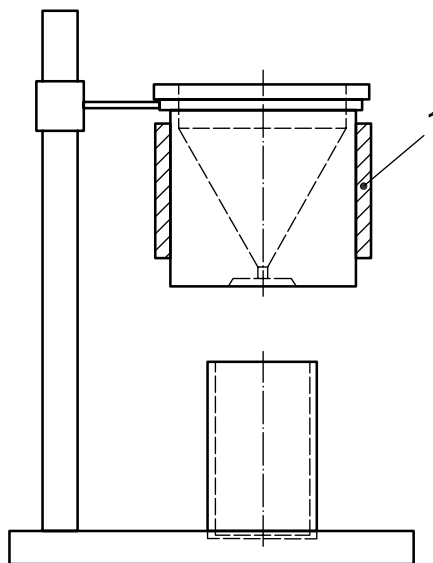

- Key**
- 1 heating device, e.g. band heater

Figure 3 — Arrangement of the stand with funnel, including heating device, and receptacle

3.4 Device for heating the funnel, e.g. an electrical band heater, to the selected and agreed testing temperature for the powder mix within the range 60 °C to 180 °C, with a maximum allowed variation of $\pm 2,5$ °C (Methods A and B).

3.5 Laboratory furnace, for heating the powder sample to the selected and agreed temperature within the range 60 °C to 180 °C, with a maximum variation of $\pm 2,5$ °C (Methods A and B).

3.6 Thermocouples, sufficient to adjust and control the temperatures of the powder mix and the funnel within $\pm 2,5$ °C from the selected temperature (Methods A and B).

3.7 Balance, with a capacity of at least 200 g, capable of weighing the test portion to an accuracy of $\pm 0,05$ g (Methods A and B).

3.8 Stopwatch, capable of measuring elapsed time to the nearest 0,1 s (Methods A and B).

NOTE An example of the insulated enclosure containing the funnel, stand and a receptacle is shown in Figure 4.



Figure 4 — Example of the insulated enclosure containing the funnel, stand and receptacle

4 Calibration of the funnel

4.1 Method A

The funnel with 2,5 mm orifice shall be calibrated as described in ISO 4490:2008, 4.1 and 4.2, with the calibration carried out at room temperature.

Any correction factor found after calibration in accordance with ISO 4490:2008, 4.2 should also be used at elevated temperatures in the range 60 °C to 180 °C covered in this part of ISO 18549.

4.2 Method B

For the funnel with an orifice of 5 mm there is no calibration method available. Any differences judged to be too big between the parties involved shall be solved by comparative measurements on the same sample(s).

5 Test sample

- 5.1 The mass of the sample shall be sufficient for two or three determinations (Method A or Method B).
- 5.2 Immediately before the test, weigh out a test portion of $50 \pm 0,1$ g (Method A) or a test portion of $150 \pm 0,1$ g (Method B) in a clean weighing dish or scoop. The dish/scoop should be able to withstand the test temperature.
- 5.3 Heat the dish/scoop with the weighed test portion in the laboratory furnace set at the appropriate temperature for the mix in question. Keep the temperature of the powder mix within $\pm 2,5$ °C of the required temperature.

6 Procedure (Methods A and B)

- 6.1 Place an empty receptacle under the orifice of the heated flowmeter funnel, which itself is kept inside a thermally insulated enclosure.
- 6.2 Pour the heated test portion quickly but carefully into the centre of the flowmeter funnel while keeping the orifice open.
- 6.3 Start the stopwatch when the powder first exits the orifice.
- 6.4 Stop the stopwatch when the last of the powder leaves the orifice and record the elapsed time to the nearest 0,1 s.
- 6.5 An alternative procedure (for a funnel with a bottom valve) is described in 6.5.1 and 6.5.2.
- 6.5.1 Pour the heated test portion quickly but carefully into the centre of the flowmeter funnel with the bottom valve closed.
- 6.5.2 Open the bottom valve so that the powder can flow into the receptacle. If the powder does not start to flow, tap the funnel gently to urge the flow.
- 6.5.3 Start and stop the stopwatch as above.

It is very important to minimize heat losses. Therefore, the heated test portions must be transferred quickly to the thermally insulated enclosure.

WARNING — Both the powder and the equipment are warm. The operation must therefore be carried out with care.

7 Result

7.1 Method A

The average of the two or three determinations is calculated and multiplied with the correction factor associated with the particular funnel used in the test.

The flow rate (at x °C) is reported in seconds per 50 g and rounded to the nearest second.

7.2 Method B

The average of the two or three determinations is calculated and the flow rate (at x °C) is reported in seconds per 150 g and rounded to the nearest second.

8 Test report

The test report shall include the following information:

- a) a reference to this part of ISO 18549;
- b) all details for the identification of the test sample;
- c) the nominal diameter of the orifice (Method A or B);
- d) the testing temperature used for the powder sample and funnel;
- e) the result obtained, and how many determinations it is based on;
- f) all operations not specified in this part of ISO 18549 or regarded as optional;
- g) details of any occurrence which may have affected the result.

iTeh STANDARD PREVIEW
(standards.iteh.ai)

[ISO 18549-2:2009](https://standards.iteh.ai/catalog/standards/sist/5b5db511-27a1-4484-939d-643247b0fa1f/iso-18549-2-2009)

<https://standards.iteh.ai/catalog/standards/sist/5b5db511-27a1-4484-939d-643247b0fa1f/iso-18549-2-2009>