**Earth-moving machinery — Performance
requirements for non-metallic fuel tanks**

*Engins de terrassement — Exigences de performance pour les
réservoirs de carburant non métalliques*

iTeh STANDARD PREVIEW
(standards.iteh.ai)

ISO 21507:2010

<https://standards.iteh.ai/catalog/standards/sist/f103d74f-8c24-43e5-a22b-21913b27d48c/iso-21507-2010>



PDF disclaimer

This PDF file may contain embedded typefaces. In accordance with Adobe's licensing policy, this file may be printed or viewed but shall not be edited unless the typefaces which are embedded are licensed to and installed on the computer performing the editing. In downloading this file, parties accept therein the responsibility of not infringing Adobe's licensing policy. The ISO Central Secretariat accepts no liability in this area.

Adobe is a trademark of Adobe Systems Incorporated.

Details of the software products used to create this PDF file can be found in the General Info relative to the file; the PDF-creation parameters were optimized for printing. Every care has been taken to ensure that the file is suitable for use by ISO member bodies. In the unlikely event that a problem relating to it is found, please inform the Central Secretariat at the address given below.

iTeh STANDARD PREVIEW
(standards.iteh.ai)

ISO 21507:2010

<https://standards.iteh.ai/catalog/standards/sist/f103d74f-8c24-43e5-a22b-21913b27d48c/iso-21507-2010>



COPYRIGHT PROTECTED DOCUMENT

© ISO 2010

All rights reserved. Unless otherwise specified, no part of this publication may be reproduced or utilized in any form or by any means, electronic or mechanical, including photocopying and microfilm, without permission in writing from either ISO at the address below or ISO's member body in the country of the requester.

ISO copyright office
Case postale 56 • CH-1211 Geneva 20
Tel. + 41 22 749 01 11
Fax + 41 22 749 09 47
E-mail copyright@iso.org
Web www.iso.org

Published in Switzerland

Foreword

ISO (the International Organization for Standardization) is a worldwide federation of national standards bodies (ISO member bodies). The work of preparing International Standards is normally carried out through ISO technical committees. Each member body interested in a subject for which a technical committee has been established has the right to be represented on that committee. International organizations, governmental and non-governmental, in liaison with ISO, also take part in the work. ISO collaborates closely with the International Electrotechnical Commission (IEC) on all matters of electrotechnical standardization.

International Standards are drafted in accordance with the rules given in the ISO/IEC Directives, Part 2.

The main task of technical committees is to prepare International Standards. Draft International Standards adopted by the technical committees are circulated to the member bodies for voting. Publication as an International Standard requires approval by at least 75 % of the member bodies casting a vote.

Attention is drawn to the possibility that some of the elements of this document may be the subject of patent rights. ISO shall not be held responsible for identifying any or all such patent rights.

ISO 21507 was prepared by Technical Committee ISO/TC 127, *Earth-moving machinery*, Subcommittee SC 1, *Test methods relating to safety and machine performance*.

This second edition cancels and replaces the first edition (ISO 21507:2005), which has been technically revised.

iTeh STANDARD PREVIEW
(standards.iteh.ai)

ISO 21507:2010
<https://standards.iteh.ai/catalog/standards/sist/fl03d74f-8c24-43e5-a22b-21913b27d48c/iso-21507-2010>

iTeh STANDARD PREVIEW
(standards.iteh.ai)

ISO 21507:2010

<https://standards.iteh.ai/catalog/standards/sist/fl03d74f-8c24-43e5-a22b-21913b27d48c/iso-21507-2010>

Earth-moving machinery — Performance requirements for non-metallic fuel tanks

1 Scope

This International Standard gives the performance requirements for non-metallic fuel tanks used by earth-moving machinery as defined in ISO 6165.

2 Normative references

The following referenced documents are indispensable for the application of this document. For dated references, only the edition cited applies. For undated references, the latest edition of the referenced document (including any amendments) applies.

ISO 3411, *Earth-moving machinery — Physical dimensions of operators and minimum operator space envelope*

ISO 3795, *Road vehicles, and tractors and machinery for agriculture and forestry — Determination of burning behaviour of interior materials*

ISO 6165, *Earth-moving machinery — Basic types — Identification and terms and definitions*

ISO 11469, *Plastics — Generic identification and marking of plastics products*

UNECE R 34:2003, *Uniform provisions concerning the approval of vehicles with regard to the prevention of fire risks, as amended*¹⁾

3 Terms and definitions

For the purposes of this document, the following terms and definitions apply.

3.1

non-metallic fuel tank

enclosed compartment on a machine made of a non-metallic material that holds fuel

3.2

operator station

space on the machine where the operator is stationed to control the machine functions

3.3

tank installation

system that includes the non-metallic tank, the filler cap and any pipes or tubes that are connected to the tank

1) United Nations Economic Commission for Europe regulation.

3.4 machine ignition temperature area

area on a machine where components have hot surfaces greater than 200 °C and could ignite materials or fuel in direct contact or close proximity

EXAMPLE Engine exhaust manifold system.

4 Requirements

4.1 Protection

The tank shall be protected, by parts of the machine frame or the outer structure, from contact with obstacles under or around the machine. Alternatively, any unprotected tank sections shall pass the impact testing specified in 5.1.5.

Tubing or piping connected to the tank shall be protected by shielding such as braided or spiral sleeves, specific guards, or guarding by location.

4.2 Corrosion resistance

The tank installation shall be designed, constructed and installed to resist any corrosion from both the internal (within the fuel system) and external environment. Where necessary, protection (e.g. plating of metal parts) should be provided.

4.3 Installation

The tank installation shall accommodate the twisting and bending movements and vibrations of the machine. The connections of flexible pipes with rigid parts of the tank installation shall be so designed and constructed as to maintain a sealed connection under these dynamic conditions.

The tank shall be securely fixed. The installation arrangement or construction shall ensure that any fuel leaking from the tank, its filler hole or its connections shall not collect into pools without a passive means for drainage.

If the tank will contain gasoline, the tank installation shall be designed and installed in the machine such that any ignition hazard due to static electricity is avoided.

If the filler hole is located on the side of the machine, the filler cap shall not, when closed, project beyond the external envelope of the machine.

The non-metallic fuel tank should be located on a machine so that it is neither in direct contact with, nor within 20 mm of, the surface of a machine ignition temperature area. If the tank is located within 20 mm of the surface of a machine ignition temperature area, then some protection for the tank shall be provided. Non-metallic tank material that has temperature resistance greater than the maximum surface temperatures of the machine ignition temperature area satisfies this requirement.

4.4 Location restriction

Tanks shall not form a wall of an operator's cab.

On machines without an operator's cab, tank surfaces or portions of the tank adjacent to the operator station shall be located outside the minimum operator space envelope as it is defined in ISO 3411.

The filler hole shall be located outside of the operator station.

iTeh STANDARD PREVIEW
(standards.iteh.ai)

https://standards.iteh.ai/catalog/standards/sist/903d74f-8c24-43e5-a22b-21913b27d48c/iso-21507-2010

4.5 Performance

Any fuel that can leak when the tank is being filled shall be directed away or shielded from any machine ignition temperature area.

5 Test methods

5.1 Pressure and mechanical strength test of the tank

Pressure and mechanical strength tests shall be performed on tanks meeting the permeability requirements of 5.2.

5.1.1 Strength test

A pressure and mechanical strength test shall be performed on a tank installation, complete with standard tank connections, filler neck and cap. The tank shall be filled to its rated capacity with water. The water temperature during the test shall be 53 °C. All connections with the tank shall be blocked. The tank shall be subjected to a relative internal pressure of 0,03 MPa at a temperature of 53 °C ± 2 °C for a period of 5 h. During the test, the tank shall not leak or crack; however, it may be permanently deformed.

5.1.2 Inversion test

An inversion test shall be performed on the tank installation in the conditions defined in 5.1.1, except that a pressure compensation device (if fitted) shall be in its operational state, i.e. not blocked.

The tank installation shall be rotated successively through 90°, 180° and 270° about an axis parallel to the longitudinal centreline of the machine to simulate machine tip/roll-over. The tank installation shall be held in each of the rotated positions for at least 5 min. Leakage through the filler cap or pressure compensation device shall not exceed a drip rate of 30 g/min.

5.1.3 Elevated pressure and temperature

If the tank will be in an application with higher pressures and temperatures than those specified in 5.1.1, the test pressure and temperature shall be raised to represent the tank installation pressure and temperature conditions on the machine.

The increased test pressure and/or temperature shall also be used for the inversion test given in 5.1.2.

5.1.4 Vacuum performance test

If the tank does not have a valve to avoid under- or over-pressure, a vacuum test shall be performed on a tank installation, complete with standard tank connections, filler neck and cap. The tank shall be empty with all connections to the tank blocked. The vacuum shall be gradually increased to a relative vacuum of 0,02 MPa at a temperature of 53 °C ± 2 °C for a period of 5 h. During this time, the tank shell shall not crack or leak; however, it may be permanently deformed.

5.1.5 Impact performance test

Unprotected tank sections (see 4.1) shall be subjected to an impact test. The tank shall be filled to its rated capacity with a water-glycol mixture or with another liquid having a low freezing point which does not change the properties of the tank material, and shall then be subjected to a perforation test. During this test, the tank temperature shall be -20 °C ± 2 °C.

A pendulum impact testing fixture (see Figure 1) shall be used for the test. The impact body shall be of steel and have the shape of a pyramid with equilateral-triangle faces and a square base, the summit and the edges being rounded to a radius of 3 mm. The centre of percussion of the pendulum shall coincide with the centre of gravity of the pyramid; its distance from the axis of rotation of the pendulum shall be 1 m.

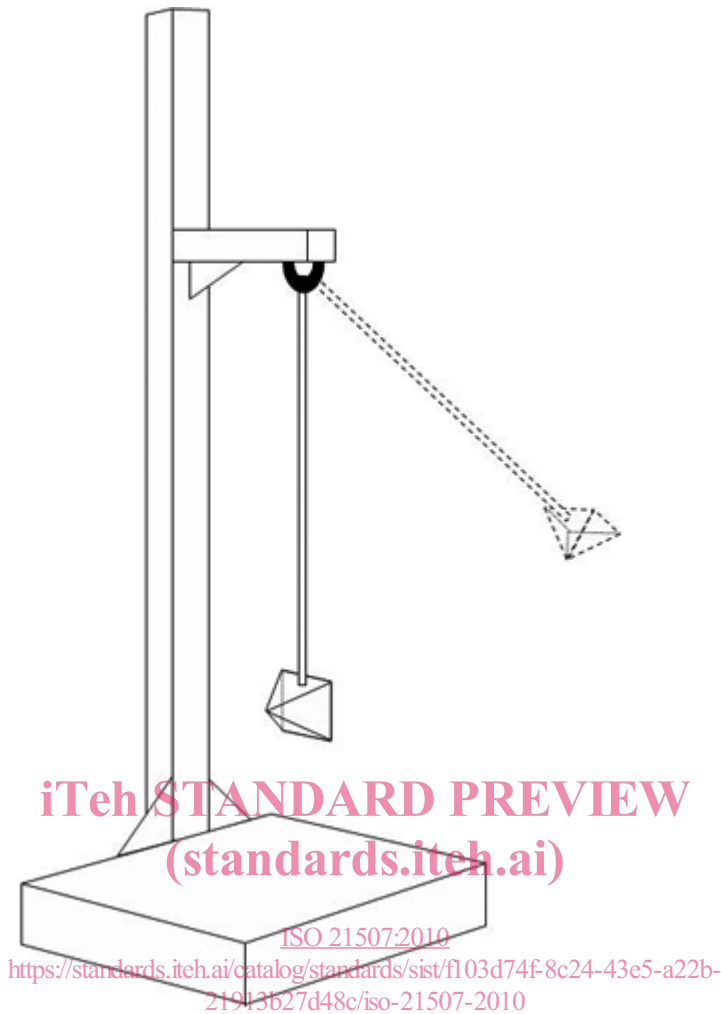

Figure 1 — Representation of an impact testing fixture

The total mass of the pendulum referred to its centre of percussion shall be 15 kg. The energy of the pendulum at the moment of impact shall be not less than 30 Nm and as close to that value as possible. The test or tests shall be selected to place the most severe requirements on relevant unprotected tank sections (see 4.1). The weakest test point or points shall be determined by the manufacturer, taking into account the shape of the tank and/or the way in which it is installed on the machine, and shall be indicated in the test report.

During the test, the tank shall be held in position and supported by the mountings on the side or sides opposite the side of impact. No leaks shall result from the test. At the option of the manufacturer, all the impact tests may be carried out on one tank or each may be carried out on a different tank.

5.2 Fuel permeability

5.2.1 General

The permeability test can be done using a test specimen of the fuel tank material, provided that the test conditions represent the test conditions for the complete tank testing (5.2.2 to 5.2.4).

NOTE Existing regional and local permeability requirements for petrol fuel tanks can be more restrictive [for example, the California Code of Regulations, Article 1, Chapter 15, Division 3, Title 13, the US Environmental Protection Agency (EPA) notice of proposed rulemaking (NPRM) 40, Code of Federal Regulations (CFR), Parts 40, 60, 63, 85, 90, 1048, 1065 and 1068].

5.2.2 Test fuel

The test fuel used for the permeability test shall be the manufacturer's recommended fuel for the tank.

5.2.3 Preconditioning

The tank shall be filled to 50 % of its rated capacity with the test fuel and stored, without being sealed, at a temperature of $40\text{ °C} \pm 2\text{ °C}$ until the weight loss per unit time becomes constant, but not for more than four weeks.

5.2.4 Fuel loss test

After preconditioning, the tank shall be emptied and refilled with the test fuel to 50 % of the rated capacity, after which the openings in the tank shall be sealed and the tank shall be stored at a temperature of $40\text{ °C} \pm 2\text{ °C}$ for 14 days. The pressure shall be adjusted to atmospheric pressure when the contents of the tank have reached the test temperature. During the ensuing test period, the loss of weight due to diffusion during the test period shall be determined.

The maximum average loss of fuel shall be 20 g/m^2 for the area of the inside of the tank (when 50 % full) that is in contact with the test fuel per 24 h of testing time.

5.3 Fire resistance

The non-metallic fuel tank shall be made of a material that

- a) has a burn rate of less than 50 mm/min, when tested in accordance with ISO 3795, or
- b) complies with UNECE R 34:2003, Annex 5.

5.4 Resistance to high temperatures

5.4.1 Test fixture

The fixture used for the test shall match the manner of installation of the tank on the machine, including the way in which the tank vent works.

5.4.2 Test conditions

The tank, filled to 50 % of its rated capacity with water at 20 °C , shall be subjected for 1 h to an ambient temperature of $95\text{ °C} \pm 2\text{ °C}$.

5.4.3 Performance criteria

The results of the test shall be considered satisfactory if, after the test, the tank is not leaking nor seriously deformed such that connections or mountings are damaged or have failed.

6 Marking

The tank shall be marked using a system based on ISO 11469, as appropriate.