**Geosynthetics — Index test procedure for
the evaluation of mechanical damage
under repeated loading — Damage
caused by granular material**

*Géosynthétiques — Mode opératoire d'essai pour évaluer
l'endommagement mécanique sous charge répétée —
Endommagement causé par des matériaux granulaires*

iTeh STANDARD PREVIEW
(standards.iteh.ai)

ISO 10722:2007

<https://standards.iteh.ai/catalog/standards/sist/860aecc4-77a0-4bc8-bf27-1a67ab06a562/iso-10722-2007>



PDF disclaimer

This PDF file may contain embedded typefaces. In accordance with Adobe's licensing policy, this file may be printed or viewed but shall not be edited unless the typefaces which are embedded are licensed to and installed on the computer performing the editing. In downloading this file, parties accept therein the responsibility of not infringing Adobe's licensing policy. The ISO Central Secretariat accepts no liability in this area.

Adobe is a trademark of Adobe Systems Incorporated.

Details of the software products used to create this PDF file can be found in the General Info relative to the file; the PDF-creation parameters were optimized for printing. Every care has been taken to ensure that the file is suitable for use by ISO member bodies. In the unlikely event that a problem relating to it is found, please inform the Central Secretariat at the address given below.

iTeh STANDARD PREVIEW
(standards.iteh.ai)

ISO 10722:2007

<https://standards.iteh.ai/catalog/standards/sist/860aecc4-77a0-4bc8-bf27-1a67ab06a562/iso-10722-2007>



COPYRIGHT PROTECTED DOCUMENT

© ISO 2007

All rights reserved. Unless otherwise specified, no part of this publication may be reproduced or utilized in any form or by any means, electronic or mechanical, including photocopying and microfilm, without permission in writing from either ISO at the address below or ISO's member body in the country of the requester.

ISO copyright office
Case postale 56 • CH-1211 Geneva 20
Tel. + 41 22 749 01 11
Fax + 41 22 749 09 47
E-mail copyright@iso.org
Web www.iso.org

Published in Switzerland

Contents

Page

Foreword.....	iv
1 Scope	1
2 Normative references	1
3 Definitions	1
4 Principle.....	1
5 Test specimens	2
5.1 Sampling.....	2
5.2 Number and dimensions of test specimens	2
6 Conditioning.....	2
7 Apparatus	2
8 Procedure	4
8.1 Damage procedure	4
8.2 Measurement of damage.....	4
9 Calculations.....	5
10 Test report	5
Bibliography	6

[ISO 10722:2007](https://standards.iteh.ai/catalog/standards/sist/860aecc4-77a0-4bc8-bf27-1a67ab06a562/iso-10722-2007)
<https://standards.iteh.ai/catalog/standards/sist/860aecc4-77a0-4bc8-bf27-1a67ab06a562/iso-10722-2007>

Foreword

ISO (the International Organization for Standardization) is a worldwide federation of national standards bodies (ISO member bodies). The work of preparing International Standards is normally carried out through ISO technical committees. Each member body interested in a subject for which a technical committee has been established has the right to be represented on that committee. International organizations, governmental and non-governmental, in liaison with ISO, also take part in the work. ISO collaborates closely with the International Electrotechnical Commission (IEC) on all matters of electrotechnical standardization.

International Standards are drafted in accordance with the rules given in the ISO/IEC Directives, Part 2.

The main task of technical committees is to prepare International Standards. Draft International Standards adopted by the technical committees are circulated to the member bodies for voting. Publication as an International Standard requires approval by at least 75 % of the member bodies casting a vote.

Attention is drawn to the possibility that some of the elements of this document may be the subject of patent rights. ISO shall not be held responsible for identifying any or all such patent rights.

ISO 10722 was prepared by the European Committee for Standardization (CEN) Technical Committee CEN/TC 189, *Geosynthetics*, in collaboration with Technical Committee ISO/TC 221, *Geosynthetics*, in accordance with the Agreement on technical cooperation between ISO and CEN (Vienna Agreement).

This first edition of ISO 10722 cancels and replaces ISO/TR 10722-1:1998.

[ISO 10722:2007](https://standards.iteh.ai/catalog/standards/sist/860aecc4-77a0-4bc8-bf27-1a67ab06a562/iso-10722-2007)

<https://standards.iteh.ai/catalog/standards/sist/860aecc4-77a0-4bc8-bf27-1a67ab06a562/iso-10722-2007>

Geosynthetics — Index test procedure for the evaluation of mechanical damage under repeated loading — Damage caused by granular material

1 Scope

This International Standard describes an index test procedure for simulating mechanical damage to geosynthetics, caused by granular material, under repeated loading. The damage is assessed visually and by the loss of tensile strength.

Other reference tests may be used to assess the damage caused by this test. The test method described is an index test procedure, using a standard granular material.

2 Normative references

The following referenced documents are indispensable for the application of this document. For dated referenced, only the edition cited applies. For undated references, the latest edition of the referenced document (including any amendment) applies.

ISO 554 *Standard atmospheres for conditioning and/or testing — Specifications*

ISO 10319, *Geosynthetics — Wide-width tensile test*

EN 933-1, *Tests for geometrical properties of aggregates — Part 1: Determination of particle size distribution — Sieving method*

ISO 9862, *Geosynthetics — Sampling and preparation of test specimens*

3 Definitions

For the purpose of this document, the following terms and definitions apply.

3.1

reference test

test used to determine a particular property of the geosynthetic being damaged in this procedure

4 Principle

A geosynthetic specimen is placed between two layers of a synthetic aggregate and subjected to a period of dynamic loading. The geosynthetic specimen is then removed from the test apparatus, examined for any visual damage and then subjected to a mechanical or hydraulic test, to measure the change in mechanical or hydraulic properties. The result is expressed as the change (in percent) of the reference property. The visual damage is also reported.

5 Test specimens

5.1 Sampling

Take specimens from the samples in accordance with ISO 9862.

5.2 Number and dimensions of test specimens

For tensile testing, cut five specimens at least 1,0 m long and between 0,5 m and 0,6 m wide from the test sample. Then cut each specimen lengthwise into two test specimens at least 1,0 m long and between 0,25 m and 0,3 m wide, one to be used in the damage procedure, the other in the reference test.

Specimens prepared for this test, which are to be subsequently subjected to a tensile test, shall be dimensioned as required in ISO 10319. When other reference tests are used, the number and dimensions of specimens shall suit the particular reference test procedure.

6 Conditioning

Condition the test specimens and conduct the tests in the standard atmosphere for testing, defined in ISO 554, i.e. at a relative humidity of $(65 \pm 5) \%$ and a temperature of $(20 \pm 2) ^\circ\text{C}$, until the change in mass between successive readings made at intervals of not less than two hours does not exceed 0,25 % of the mass of the test specimens.

The test shall be performed in the same atmosphere.

Conditioning and/or testing at a specified relative humidity may be omitted if it can be shown that the results are not affected by this omission.

ITeH STANDARD PREVIEW
(standards.iteh.ai)
<https://standards.iteh.ai/catalog/standards/sist/860aecc4-77a0-4bc8-bf27-1a67ab06a562/iso-10722-2007>

7 Apparatus

7.1 Compression machine, which can be controlled to produce a sinusoidal pressure of between (500 ± 10) kPa and $(5 \pm 0,5)$ kPa on the loading plate, at a frequency of 1 Hz.

7.2 Test container.

The test container shall be a rigid metal box of minimum 300 mm by 300 mm internal dimensions in the plane, and shall consist of two parts, each 75 mm deep. The two parts of the box may be bolted or clipped together during the damage procedure. Shims of sufficient thickness to allow the specimen to be retained without generating any tension shall be fitted between the two parts. The lower part of the box shall be mounted on a rigid base which deflects less than 1 mm when the test load is applied directly to the base, or shall be rigidly fixed to the hydraulic piston of the compression machine. Figure 1 shows a typical arrangement of the apparatus.

Dimensions in millimetres

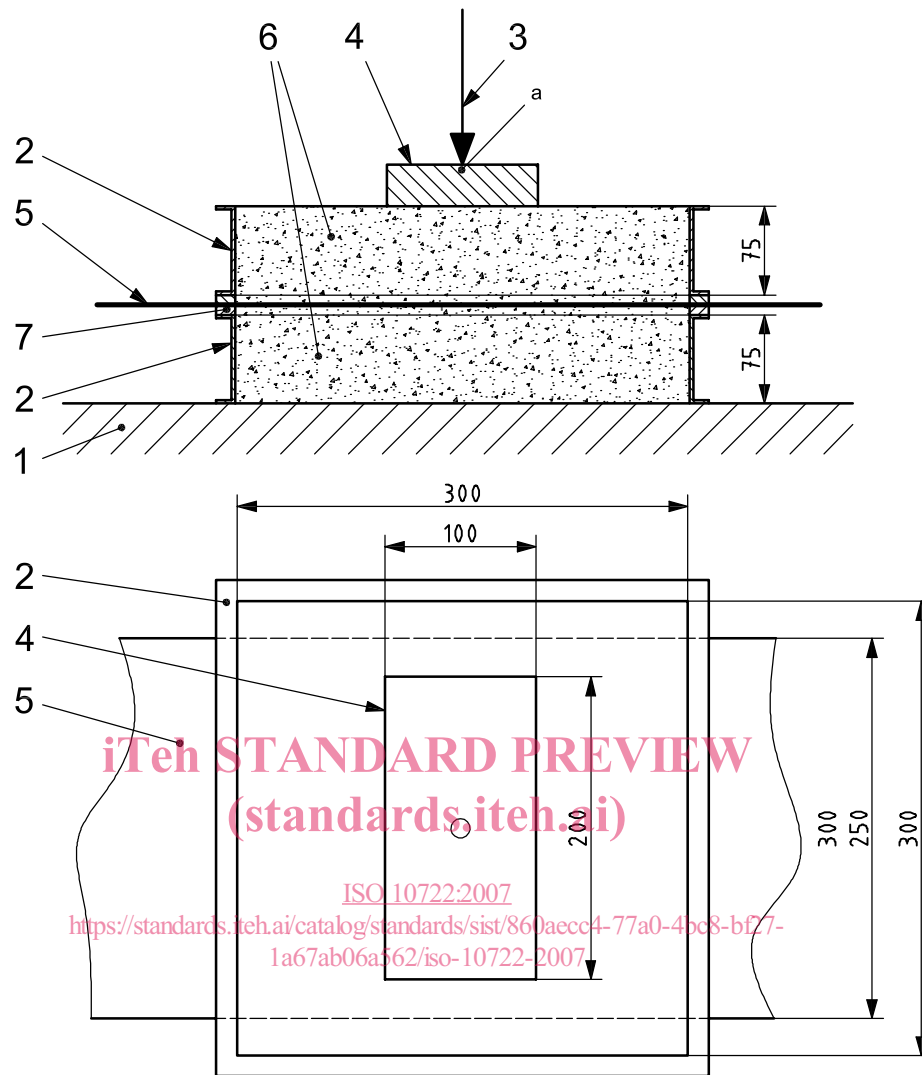

Key

- 1 rigid base support
- 2 rigid metal box [in two parts, 300 mm × 300 mm plan dimensions (min)]
- 3 applied load (cyclic loading 5 kPa to 500 kPa at 1 Hz)
- 4 loading plate (100 mm × 200 mm)
- 5 geosynthetic specimen (surplus rolled up carefully outside the container during the test procedure)
- 6 aggregate (compacted in the lower box, loose in the upper box)
- 7 shims
- a Spherical seating.

Figure 1 — Section through apparatus

7.3 Loading plate, with dimensions 100 mm by 200 mm, made of steel or aluminium, with adequate stiffness to transmit the loading forces to the aggregate without deflection.

7.4 Aggregate.

The aggregate used in the damage procedure is a sintered aluminium oxide¹⁾, with the following requirement on grain size:

- when tested in accordance with EN 933-1, 100 % of the aggregate shall pass a 10 mm sieve and 0 % shall pass a 5 mm sieve.

If necessary, the aggregate shall be wet sieved on a 5 mm aperture sieve at the first use and after every three uses, and any material passing the sieve shall be discarded. The aggregate shall be totally discarded after twenty uses.

8 Procedure

8.1 Damage procedure

Fill the lower part of the test container with the aggregate. Place the aggregate in two equal layers, each compacted with a flat plate loaded to a pressure of (200 ± 2) kPa, for 60 s, over the whole area of the test container. Strike the top layer off level with the top of the lower part of the container.

Place the specimen across the top of the lower part of the container, the centre of the specimen aligned with the centre of the container and with the free edges equally spaced from each side of the container. If necessary, roll up the free ends of the specimen outside the container in such a way that the specimen is not damaged during the test. Position the upper part of the container and bolt or clip it into position making sure the specimen is smooth, free from wrinkles but not pre-tensioned. Then, loosely fill the upper part of the container with aggregate to a depth of 75 mm above the specimen.

Position the loading plate centrally in the container and apply a load of $(5 \pm 0,5)$ kPa. Set the loading apparatus to produce a cyclic loading of between (10 ± 10) kPa minimum and (500 ± 10) kPa maximum, at a frequency of 1 Hz for 200 loading cycles. Determine the pressure using the area of the loading platen, not the area of the test container.

Remove the specimen carefully from the test container, ensuring that no additional damage occurs during removal.

Repeat the procedure for other specimens from the sample.

8.2 Measurement of damage

Measure the damage by subjecting the reference sub-specimen and the damaged sub-specimen to the same reference test. The reference test shall normally be ISO 10319, but other mechanical or hydraulic reference tests may be selected, i.e. ISO 12236, ISO 12956 or ISO 11058.

1) A suitable aggregate can be obtained from:

Explorer srl, Viale Regina Pacis, 11, I-41049 Sassuolo (MO), Italy;

Semanaz et Cie, 107 Quai du Rancy, Port de Bonneuil, F-94388 Bonneuil-sur-Marne, France;

Kuhmichel Abrasiv GmbH, Asikos Strahlmittel GmbH, D-46535 Dinslaken, Germany.

This information is given for the convenience of users of this International Standard and does not imply an approval of the provider by CEN or ISO.

The reference sub-specimen is not a virgin product, but it consists of a specimen installed over the aggregate, subsequently subjected to a static pressure of (500 ± 10) kPa for 60 s, and finally taken out to be submitted to the reference test.

The reference test to be used shall be agreed between parties prior to the commencement of the test.

Optionally, the specimen is visually examined for damage and an assessment of the damage is made. The examination includes making a record of the number of holes in the specimen and a qualitative assessment of any damage.

9 Calculations

Calculate the change in the reference property as

$$\Delta R = 100 \times \left(\frac{R_d}{R_0} \right)$$

where

R_d is the reference test value of the damaged specimen;

R_0 is the reference test value of the reference specimen;

ΔR is the percentage retained of the reference test value (damage index).

Calculate the mean value of ΔR , the standard deviation and the coefficient of variation.

[ISO 10722:2007](https://standards.iteh.ai/catalog/standards/sist/860aecc4-77a0-4bc8-bf27-1a67ab06a562/iso-10722-2007)

10 Test report

<https://standards.iteh.ai/catalog/standards/sist/860aecc4-77a0-4bc8-bf27-1a67ab06a562/iso-10722-2007>

The test report shall include the following information:

- a) the number and date of this International Standard (i.e. ISO 10722);
- b) identification of the sample, date of receipt and date of testing;
- c) the conditioning atmosphere;
- d) the temperature at which the test was carried out;
- e) the orientation of the sample and specimens cut from the material roll or sheet;
- f) the visual damage report;
- g) the test method used to measure the reference value;
- h) the mean value of the percentage retained in the reference value;
- i) the standard deviation and coefficient of variation of the percentage retained of the reference value;
- j) the aggregate used in the test;
- k) any deviation from this procedure.