



Standard Test Methods for Measurement of Extreme Pressure Properties of Fluid Lubricants (Falex Pin and Vee Block Methods)¹

This standard is issued under the fixed designation D 3233; the number immediately following the designation indicates the year of original adoption or, in the case of revision, the year of last revision. A number in parentheses indicates the year of last reapproval. A superscript epsilon (ϵ) indicates an editorial change since the last revision or reapproval.

1. Scope

1.1 These test methods cover two procedures for making a preliminary evaluation of the load-carrying properties of fluid lubricants by means of the Falex Pin and Vee Block Test Machine.

NOTE 1—Additional information can be found in Appendix X1 regarding coefficient of friction, load gage conversions, and load gage calibration curve.

1.2 The values stated in SI units are to be regarded as standard. Because the equipment used in these test methods is available only in inch-pound units, the SI units are omitted when referring to the equipment and the test specimens.

1.3 *This standard does not purport to address all of the safety concerns, if any, associated with its use. It is the responsibility of the user of this standard to establish appropriate safety and health practices and determine the applicability of regulatory limitations prior to use.*

2. Referenced Documents

2.1 ASTM Standards:

B 16 Specification for Free-Cutting Brass, Rod, Bar, and Shapes for Use in Screw Machines²

D 2670 Test Method for Measuring Wear Properties of Fluid Lubricants (Falex Pen and Vee Block Method)³

D 2783 Test Method for Measurement of Extreme-Pressure Properties of Lubricating Fluids (Four-Ball Method)³

3. Terminology

3.1 Definitions of Terms Specific to This Standard:

3.1.1 *actual gage load, n*—the value obtained from the gage while running the test and before any corrections are made.

3.1.1.1 *Discussion*—This gage reading is irrespective of the particular gage used, and corrections are made by comparison

to a standard reference.

3.1.2 *direct load, n*—that which is applied linearly, bisecting the angle of the vee block corrected to either the 800 or 3000-lbf gage reference.

3.1.2.1 *Discussion*—This load is equivalent to the true load times the $\cos 42^\circ$.

3.1.3 *true load, n*—the sum of the applied forces normal to the tangents of contact between the faces of one vee block and the journal pin corrected to the 4500 lbf gage reference line.

3.1.4 *true load failure value, n*—the true load at which the lubricant tested can no longer support the applied load resulting in either test pin or shear pin breakage, or inability to maintain or increase load.

3.1.4.1 *Discussion*—This value is also referred to as the limit of extreme pressure.

4. Summary of Test Methods

4.1 Both test methods consist of running a rotating steel journal at 290 ± 10 rpm against two stationary V-blocks immersed in the lubricant sample. Load is applied to the V-blocks by a ratchet mechanism. In Test Method A (Note 1), increasing load is applied continuously. In Test Method B (Note 1), load is applied in 250-lbf (1112-N) increments with load maintained constant for 1 min at each load increment. In both methods the load-fail value obtained is the criteria for level of load-carrying properties. Both methods require calibration of the load gage and reporting of test results as true (corrected) loads rather than actual gage loads.

NOTE 2—Test Method A is referred to as the Falex Run-Up Test. Test Method B is referred to as the Falex One-Minute Step Test.

5. Significance and Use

5.1 Evaluations by both test methods differentiate between fluids having low, medium, and high levels of extreme-pressure properties. The user should establish any correlation between results by either method and service performance.

NOTE 3—Relative ratings by both test methods on the reference fluids covered in Table 1 and Table 2 are in good general agreement with four-ball weld-point relative ratings obtained on these same reference fluids, covered in Test Method D 2783.

¹ These test methods are under the jurisdiction of ASTM Committee D-2 on Petroleum Products and Lubricants and are the direct responsibility of Subcommittee D02.0L on Industrial Lubricants.

Current edition approved Aug. 15, 1993. Published October 1993. Originally published as D 3233 – 86. Last previous edition D 3233 – 92.

² *Annual Book of ASTM Standards*, Vol 02.01.

³ *Annual Book of ASTM Standards*, Vol 05.01.



TABLE 1 Results of Cooperative Tests on Reference Fluids L-XI-1-2-A, B, C, D, E^A TEST METHOD A

Laboratory	Test	L-XI-1-2-A Fail Load, lbf		L-XI-1-2-B Fail Load, lbf		L-XI-1-2-C Fail Load, lbf		L-XI-1-2-D Fail Load, lbf		L-XI-1-2-E Fail Load, lbf	
		Gage	True	Gage	True	Gage	True	Gage	True	Gage	True
A	1	1200	840	1200	840	4500 +	4100 +	4300	3950	2600	2100
	2	1275	920	1275	920	4500 +	4100 +	4500 +	4100 +	2400	1925
B	1	800	860	1000	1050	4500 +	4250 +	4100	3900	2050	2050
	2	850	900	950	1025	4500 +	4250 +	4300	4100	1950	1950
C	1	725	990	775	1020	4500 +	3200 +	3950	2900	1350	1460
	2	650	910	750	980	4500 +	3200 +	4100	3000	1300	1430
D	1	1400	1050	1100	770	4500 +	3500 +	4500 +	3500 +	2900	2150
	2	1400	1050	1250	900	4500 +	3500 +	4500 +	3500 +	2650	1975
E	1	825	900	1000	1060	4450	4500 +	4100	4475	1825	1970
	2	750	820	925	1000	4450	4500 +	4150	4500	1825	1970
F	1	1000 ^B	920 ^B	1000	800	4500 +	4500 +	3500	4500	1850	1900
	2	990 ^B	910 ^B	1050	850	4500 +	4500 +	2900	3510	1720	1720
G	1	800	900	690	800	4000	4275	3325	3625	1430	1600
	2	700	800	660	750	3750	4000	3150	3450	1500	1675
H	1	700	700	1000	1000	4500 +	4500 +	3750	3750	1900	1900
	2	700	700	1000	1000	4500 +	4500 +	4000	4000	1650	1650
I	1	750	600	1250	1000	4500 +	3750 +	4500 +	3750 +	1750	1450
	2	750	600	1000	800	4500 +	3750 +	4500 +	3750 +	1750	1450
Min Avg			600		775				2950 ^C		1445
Max Avg			1050		1037				4488 ^C		2063
Grand Avg			854		920				3809 ^C		1796
		Repeatability s = 0.0624 r = 0.179 (TL) ^D				Reproducibility S = 0.140 R = 0.402 (TL) ^D					

^AReference fluids used and described in Test Method D 2783.

^BCalibration curves shifted.

^CSix laboratories.

^DTL = average true load, lbf, of sample tested.

6. Apparatus

6.1 *Falex Pin and Vee Block Test Machine*,⁴ illustrated in Fig. 1, Fig. 2, and Fig. 3, fitted with 4500-lbf (20 000-N) gage or 3000-lbf (13 350-N) gage.

6.2 *Required for Calibration:*

6.2.1 *Allen Screw*, with attached 10-mm Brinnell ball.⁵

6.2.2 *Back-Up Plug*.⁵

6.2.3 *Standard Test Coupon*,⁵ soft, annealed copper, Hb 37–39.

6.2.4 *Brinnell Microscope*, or equivalent.

6.2.5 *Timer*, graduated in seconds and minutes.

6.2.6 *Rule*, steel, 6-in. (approximately 150-mm) long.

7. Reagents and Materials

7.1 *Standard Coined-Blocks*,⁵ 96 ± 1° angle, AISI C-1137 steel, HRC 20 to 24, surface finish 5 to 10 µin. (1.3 × 10⁻⁷ to 2.5 × 10⁻⁷m), rms.

7.2 *Standard Test Journals*,⁵ ¼ in. (6.35 mm) outside diameter by 1¼ in. (31.75 mm) long, AISI 3135 steel, HRB 87

⁴ The Falex Pin and Vee Block Test Machine, available from the Falex Corp., 1020 Airpark Dr., Sugar Grove, IL 60554 has been found satisfactory for this purpose. A new model of this machine has been available since 1983. Certain operating procedures are different for this new model. Consult instruction manual of machine for this information.

⁵ Available from Falex Corp., 1020 Airpark Dr., Sugar Grove, IL 60554.

to 91 on a ground flat surface, surface finish 5 to 10 µin. (1.3 × 10⁻⁷ to 2.5 × 10⁻⁷ m) rms.

7.3 *Locking Pins*,⁵ ½H brass, conforming to Specification B 16.

7.4 *Solvent*, safe, nonfilming, nonchlorinated.

NOTE 4—Petroleum distillate and benzene, formerly used as solvents in this method, have been eliminated due to possible toxic effects. Each user should select a solvent that can meet applicable safety standards and still thoroughly clean the parts.

8. Preparation of Apparatus

8.1 *Cleaning:*

8.1.1 Thoroughly clean the V-blocks, test journals, lubricant cup, and supports for V-blocks and test journals by washing, successively, with solvent selected in 7.4. Dry the V-blocks, test journals, lubricant cup, and supports, by allowing the final solvent to evaporate in air.

8.1.2 After cleaning, handle the test pieces with care to prevent contamination. Particularly, avoid contact of fingers with mating surfaces of V-blocks and test journals.

8.2 *Assembly:*

8.2.1 Insert the test journal into the test shaft and secure with a new brass locking pin, as shown in Fig. 1 and Fig. 3.

8.2.2 Insert the V-blocks into the recesses of the loading device and swing the V-blocks inward to contact the journal so

TABLE 2 Results of Cooperative Tests on Reference Fluids L-XI-1-2-A, B, C, D, E^A TEST METHOD B

Laboratory	Test	L-XI-1-2-A Fail Load, lbf		L-XI-1-2-B Fail Load, lbf		L-XI-1-2-C Fail Load, lbf		L-XI-1-2-D Fail Load, lbf		L-XI-1-2-E Fail Load, lbf	
		Gage	True	Gage	True	Gage	True	Gage	True	Gage	True
A	1	1100	750	1400	1000	4150	3750	4350	4000	2750	2250
	2	1100	750	1400	1000	4350	4000	4150	3750	2200	1750
B	1	670	750	940	1000	4200	4000	3900	3750	2000	2000
	2	670	750	670	750	3900	3750	4200	4000	1750	1750
C	1	520	750	520	750	4100 +	3000 +	4100	3000	1750	1750
	2	520	750	790	1000	4100 +	3000 +	4100 +	3000 +	1750	1750
D	1	1600	1250	1080	750	4500 +	3500 +	4500 +	3500 +	3000	2250
	2	1600	1250	1080	750	4500 +	3500 +	4500 +	3500 +	3300	2500
E	1	700	750	925	1000	3850	4250	3850	4250	1380	1500
	2	700	750	925	1000	4150	4500	3650	4000	1850	2000
F	1	1075 ^B	1000 ^B	950	750	3350	4250	3350	4250	1925	2000
	2	1075 ^B	1000 ^B	950	750	3500	4500	3050	3750	1560	1500
G	1	660	750	660	750	3500	3750	3000	3250	1550	1750
	2	660	750	800	1000	3200	3500	2800	3000	1350	1500
H	1	750	750	1000	1000	3500	3500	4250	4250	1500	1500
	2	750	750	1000	1000	4000	4000	4000	4000	1750	1750
I	1	930	750	910	750	4400	3750	4400 +	3750 +	1800	1500
	2	930	750	910	750	4400	3750	4400 +	3750 +	1800	1500
Min Avg		750		750		3625 ^C		3125 ^D		1500	
Max Avg		1250		1000		4375 ^C		4125 ^D		2375	
Grand Avg		833		875		3932 ^C		3837 ^D		1846	
		Repeatability				Reproducibility					
		$s = 0.0624$				$S = 0.137$					
		$r = 0.179 (TL)^E$				$R = 0.391 (TL)^E$					

^AReference fluids used and described in Test Method D 2783.

^BCalibration curves shifted.

^CSeven laboratories.

^DSix laboratories.

^ETL = average true load, lbf, of sample tested.

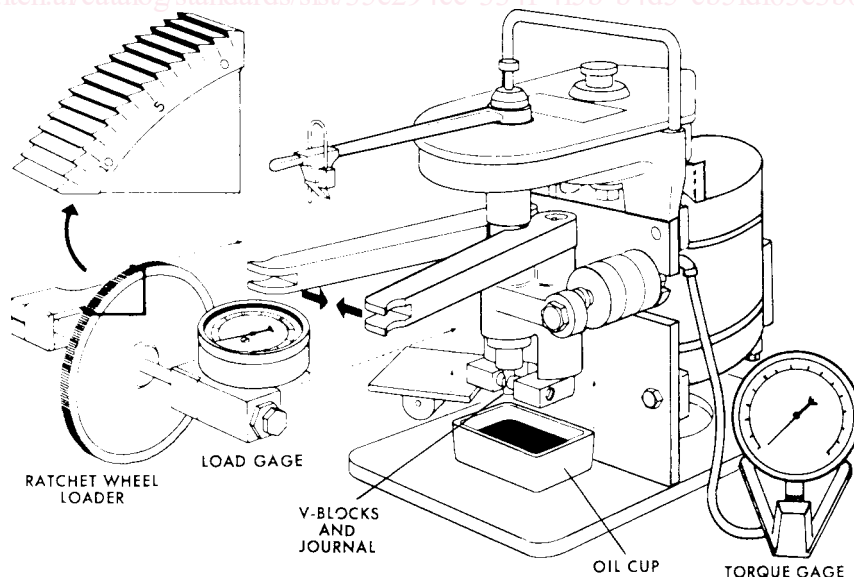

FIG. 1 Schematic Diagram of Falex Standard Pin and Vee Block Test Machine

that the V-grooves are aligned with the journal major axis, as shown in Fig. 1 and Fig. 3.

8.2.3 Place 60 mL of test lubricant in the lubricant cup and

raise the cup so that the V-blocks are immersed in the test lubricant. With highly viscous fluids open the jaws slightly to ensure that the wear surfaces are covered with the lubricant.



FIG. 2 Falex Digital Pin and Vee Block Test Machine

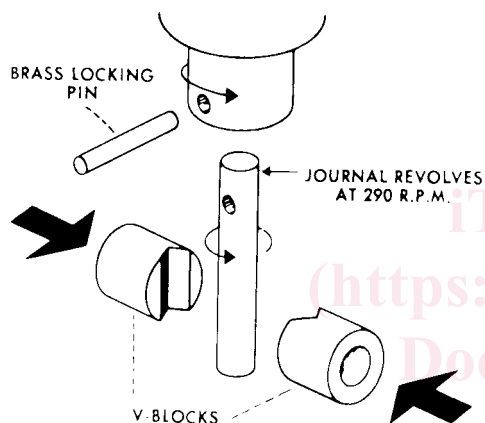

FIG. 3 Exploded View of V-Blocks and Journal Arrangement, Falex Pin and Vee Block Test Machines

8.2.4 Place the automatic loading device, with attached gage, on the jaw arms.

9. Preparation of True Load Calibration Curve

9.1 On log-log paper (K & E 467080 or equivalent) draw a straight-line plot of load, pounds-force (newtons) (ordinate), versus indentation diameter, millimetres (abscissa), using the data points shown below. Label this curve “True Load” (Note 5).

Load, lbf (N) (Ordinate)	Diameter, mm (Abcissa)
500 (2224)	2.62
1000 (4450)	3.42
1500 (6672)	4.00
2000 (8896)	4.47

NOTE 5—Fig. 3 shows the true-load calibration curve for the prescribed 4500-lbf (20 000-N) gage, prepared as covered in 9.1. Copies of Fig. 4, 8 by 11 in., are available at a nominal cost from ASTM. Although not originally used in development of these test methods, the 3000-lb direct reading load gage should be satisfactory providing results are corrected and reported with respect to the true load (4500-lbf) reference line. Refer to Test Method D 2670 for calibration of 3000-lb load gage.

10. Calibration of Load Gage 4500 lbf (20 000 N)

10.1 Remove the Allen set screw and ½-in. (12.70-mm) ball

from the left jaw socket (Fig. 5).

10.2 Insert the special Allen screw with the attached 10-mm Brinnell ball into the working face of the left jaw. Adjust so that the ball projects about 5/32 in. (approximately 4 mm) from the face of the jaw.

10.3 Insert the back-up plug in the counterbore of the right-hand jaw. Adjust so that the plug projects about 1/32 in. (approximately 0.8 mm) from the face.

10.4 Support the standard test coupon so that the upper edge of the coupon is about 3/32 in. (approximately 2.5 mm) below the upper surface of the jaws. Place a steel rule across the face of the jaws. Adjust the Allen screw with the attached 10-mm ball until the face of the jaws are parallel to the steel rule with the test coupon in position for indentation.

10.5 With the test coupon in position for the first impression, place the load gage assembly on the level arms. Remove the slack from the assembly by moving the ratchet wheel by hand.

10.6 Place the loading lever on the ratchet wheel and actuate the motor. Allow the motor to run until the load gage indicates a load of 500 lbf (2224 N). A slight take-up on the ratchet wheel is required to hold the load due to the ball sinking into the test coupon. After a 500-lbf (2224-N) load is obtained, hold for 1 min for the indentation to form.

10.7 Turn off the machine and back off the load until the test coupon is free of the jaws. Advance the test coupon approximately 3/8 in. (approximately 9.5 mm). Additional indentations should be separated by a minimum distance of 2.5 times the diameter of the initial indentation. Check the alignment of the jaws, and repeat the procedure described in 10.6 at gage loads of 1000, 1500, and 2000 lbf (4448, 6672, and 8896 N).

10.8 Remove the load gage assembly and test coupon and measure the diameter of each indentation to 0.01 mm with a microscope. Make three measurements of the indentation diameter, rotating the test coupon to ensure that no two measurements represent the same points. Average the three measurements of each impression and record.

10.9 Plot the four impression readings on the same log-log plot of true load prepared as prescribed in 9.1 and shown as Fig. 4. Draw a straight line through the four impression

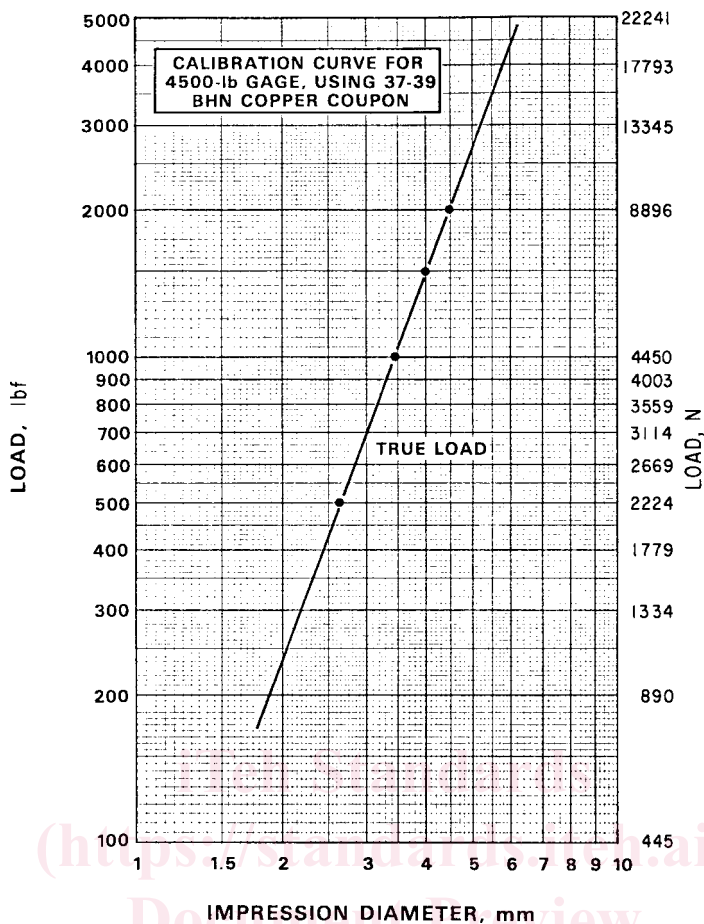

FIG. 4 Calibration Curve for 4500-lb Gage, Using 37-39 HB Copper Coupon

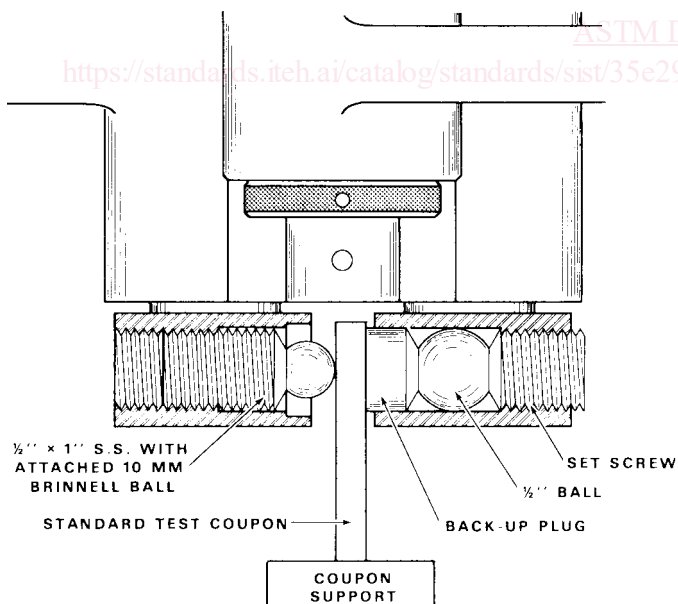

FIG. 5 Schematic Drawing of Calibration Accessories for Falex Pin and Vee Block Test Machines

tions should be made to ensure correct values are being reported for true load.

TEST METHOD A

11. Determination of Actual Gage Load for Run-In

11.1 The procedure, Section 12, requires a run-in at an actual gage load equivalent to 300-lbf (1334-N) true load (264-lbf direct load). This actual gage load is obtained as follows from the plot of actual gage load and true load prepared in Sections 9 and 10: Locate 300 lbf (1334 N) on the true load curve (264-lbf direct load). Through this point draw a vertical line to intersect the actual gage load curve. Through this point of intersection draw a horizontal line to the left-hand or right-hand load scale and read the actual gage load value. Record this actual gage load for run-in on a suitable reporting form.

NOTE 7—A suitable reporting form for Test Methods A and B, and data obtained on one of the reference fluids by one of the cooperating laboratories, is shown in Table 3. Fig. 6 shows the calibration curves used by the laboratory reporting the data in Table 3.

12. Procedure

12.1 Run-In:

12.1.1 Turn on “Heat Control” switch and heat test lubricant to $120 \pm 5^\circ\text{F}$ ($51.7 \pm 3^\circ\text{C}$); then turn off the switch.

12.1.2 Remove slack from assembly by moving the ratchet wheel by hand. At this setting the torque gage should read zero,

readings and label the line “Actual Gage Load.”

NOTE 6—Currently, load gages are calibrated at the factory such that the actual 4500-lb gage load is equivalent to true load. Periodic calibra-



TABLE 3 Suggested Report Form, Test Methods A and B, Showing Data

Operator: Laboratory A			Gage Type:		
Test Sample: L-XI-1-2-E					
Calibration Indentation Results:	500 lbf =	2.13 mm	1500 lbf =	3.53 mm	
	1000 lbf =	2.90 mm	2000 lbf =	4.06 mm	
TEST METHOD A					
Run-In: 5 min at 520 lbf actual gage load, equivalent to 300 lbf true load.					
	Actual Gate Load, lbf, at Failure		Equivalent True Load, lbf at Failure		
Test No. 1	2600		2100		
Test No. 2	2400		1925		

TEST METHOD B					
Run-In: 5 min at 520 lbf actual gage load, equivalent to 300 lbf true load.					
True Load, lbf	Equivalent Actual Gage Load, lbf	Test No. 1	Test No. 2		
500	800	pass	pass		
750	1100	pass	pass		
1000	1400	pass	pass		
1250	1650	pass	pass		
1500	1950	pass	pass		
1750	2200	pass	fail		
2000	2450	pass	fail		
2250	2750	fail	fail		
2500	3000	fail	fail		
2750	3200	fail	fail		
3000	3400	fail	fail		
3250	3700	fail	fail		
3500	3900	fail	fail		
3750	4150	fail	fail		
4000	4350	fail	fail		
4250					
4500					

iTeH Standards
(<https://standards.iteh.ai>)
Document Preview

ASTM D3233-93(1998)

<https://standards.iteh.ai/catalog/standards/sist/35e294ce-334f-4f5b-b4d5-cb5fd63e3b0/astm-d3233-93-1998>

or be adjusted to zero.

12.1.3 Actuate the motor, engage the automatic loading ratchet, and increase the load to a gage load equivalent to 300-lbf (1334-N) true load (264-lbf direct load), as determined in 8.1. Disengage the loading ratchet, start the timer, and allow the machine to run at this loading for a 5-min run-in period.

NOTE 8—Maintain load at near constant by taking up the load manually or automatically by means of the ratchet wheel if necessary.

12.2 Test:

12.2.1 Re-engage the automatic loading ratchet and leave it engaged until failure (Note 9) or until the highest indicated actual gage reading is reached. Stop the motor at failure or at the highest indicated actual gage load when no failure is obtained. Record the gage load at failure. Record 4500 lbf (20 000 N) if no failure is obtained.

NOTE 9—Failure is indicated by (a) breakage of shear pin or test pin, or (b) inability to take up the load automatically by means of the ratchet wheel.

12.2.2 Using the calibration curves prepared in Sections 9 and 10, determine and record the true load failure equivalent to the actual gage load failure, or, if no failure, the true load equivalent to the highest indicated actual gage load, with a plus (+) sign after the true load value.

NOTE 10—To convert actual gage load to true load, locate the gage load on the actual gage load curve. Through this point draw a vertical line to intersect the true load curve. Through this point of intersection draw a horizontal line to the left-hand or right-hand load scale and read the true load value.

TEST METHOD B

13. Determination of Actual Gage Load for Run-In and 250-lbf (1112-N) True Load Increments

13.1 The procedure, Section 14, requires a run-in at an actual gage load equivalent to 300-lbf (1334-N) true load (264-lbf direct load), and testing at incremental gage loadings equivalent to 250-lbf (1112-N) true load (224-lbf direct load) over the range from 500 to 4500-lbf (2224 to 20 000-N) true load (412 to 2885-lbf direct load). Determine the equivalent actual gage loads as prescribed in Section 8, and Test Method A. Record on a suitable reporting form, such as shown in Table 3.

14. Procedure

14.1 *Run-In*—Use same procedure as prescribed in 12.1, Test Method A.

14.2 Test:

14.2.1 Re-engage the automatic loading ratchet and leave it engaged until the actual gage reading is equivalent to 500-lbf