

---

# International Standard



# 501

---

INTERNATIONAL ORGANIZATION FOR STANDARDIZATION • МЕЖДУНАРОДНАЯ ОРГАНИЗАЦИЯ ПО СТАНДАРТИЗАЦИИ • ORGANISATION INTERNATIONALE DE NORMALISATION

---

## Coal — Determination of the crucible swelling number

*Charbon — Détermination de l'indice de gonflement au creuset*

**Second edition — 1981-11-01**

**iTeh STANDARD PREVIEW**  
**(standards.iteh.ai)**

[ISO 501:1981](#)

<https://standards.iteh.ai/catalog/standards/sist/fe044e72-b1ef-4f12-974b-7fa199aceeb1/iso-501-1981>

---

**UDC 662.66 : 536.416**

**Ref. No. ISO 501-1981 (E)**

**Descriptors** : coal, tests, physical tests, swelling, swelling index, coking.

## Foreword

ISO (the International Organization for Standardization) is a worldwide federation of national standards institutes (ISO member bodies). The work of developing International Standards is carried out through ISO technical committees. Every member body interested in a subject for which a technical committee has been set up has the right to be represented on that committee. International organizations, governmental and non-governmental, in liaison with ISO, also take part in the work.

Draft International Standards adopted by the technical committees are circulated to the member bodies for approval before their acceptance as International Standards by the ISO Council.

**iTeh STANDARD PREVIEW**  
(standards.iteh.ai)

International Standard ISO 501 was developed by Technical Committee ISO/TC 27, *Solid mineral fuels*.

This second edition was submitted directly to the ISO Council, in accordance with clause 5.10.1 of the Directives for the technical work of ISO. It cancels and replaces the first edition (i.e. ISO 501-1974), which had been approved by the member bodies of the following countries :

|                |                       |                |
|----------------|-----------------------|----------------|
| Australia      | Italy                 | Spain          |
| Austria        | Japan                 | Sweden         |
| Belgium        | Netherlands           | Switzerland    |
| Brazil         | New Zealand           | Turkey         |
| Chile          | Philippines           | United Kingdom |
| Czechoslovakia | Poland                | USA            |
| Denmark        | Portugal              | USSR           |
| Germany, F. R. | Romania               | Yugoslavia     |
| India          | South Africa, Rep. of |                |

The member body of the following country had expressed disapproval of the document on technical grounds :

France

# Coal – Determination of the crucible swelling number

## 1 Scope and field of application

This International Standard specifies a method of determining the swelling properties of a coal when heated in a covered crucible.

## 2 Principle

The sample is heated in a covered crucible under standard conditions to a final temperature of  $820 \pm 5$  °C. The coke button obtained is classified by comparison with the outlines of a set of standard profiles. The number of the profile most closely corresponding to the coke button obtained is the crucible swelling number.

Gas or electrical heating may be used. When using an electrically heated apparatus, the results obtained should be the same (within 1/2 unit) as those obtained by the gas heating method.

crucible before carrying out the test.) Crucibles and lids of other ceramic materials may be used, provided that the results agree with those obtained with silica crucibles. The crucible shall conform to the following specifications :

External height :  $26 \pm 0,5$  mm

External diameter at top :  $41 \pm 0,75$  mm

Minimum internal diameter at base : 11 mm

Mass : 11 to 12,75 g

Capacity : 16 to 17,5 ml

ISO 501:1981

<https://standards.iteh.ai/catalog/standards/sist/fe044e72-b1ef-4f12-974b-419999999999/iso-501-1981>

Dimensions in millimetres

## 3 Preparation of sample

The coal used for the determination of swelling number is the analysis sample ground to pass a 200  $\mu\text{m}$  sieve. Avoid both very fine grinding and undue exposure of the ground coal to the atmosphere since they are liable to lead to erroneous results. Prepare the coal on the same day that the test is carried out. With coals especially liable to oxidation, carry out the test as soon as possible and not more than 2 h after grinding, unless the sample can be stored in an inert atmosphere.

Before commencing the determination, mix the air-dried sample of coal thoroughly for at least 1 min, preferably by mechanical means.

## 4 Gas heating method

### 4.1 Apparatus

**4.1.1 Crucible and lid** (see figure 1) : Translucent silica crucible, squat form, and silica lid with ring handle. (If the lower surface of the crucible lid is not flat, difficulty may be experienced in assessing the swelling number of the coal. A small mica plate shall then be inserted between the lid and the

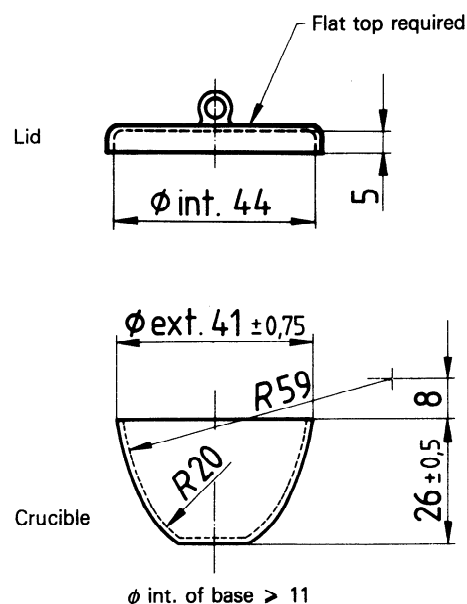

Figure 1 – Crucible with lid for swelling test

**4.1.2 Pierced silica lid** (see figure 2), similar to that described in 4.1.1 but with a 6 mm hole to accommodate the thermocouple (4.1.7).

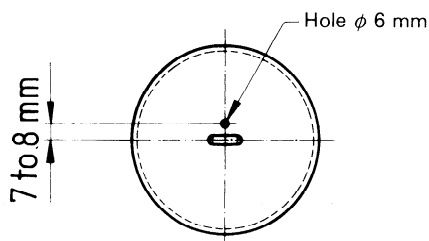

Figure 2 — Pierced crucible lid

**4.1.3 Triangle**, consisting of silica tubing of 6 to 6,5 mm external diameter mounted on nickel/chromium wire, the length of side being approximately 65 mm.

Unprotected nickel/chromium wire may be used, provided that it is sufficiently rigid.

**4.1.4 Burner**, capable of giving the required standard heating conditions. The following types have been found satisfactory:

- a) A Teclu type burner; with coal gas of calorific value of about 20 MJ/m<sup>3</sup>, the internal diameter of the burner tube should be approximately 12,5 mm.
- b) A Meker type burner; with natural gas of calorific value of about 40 MJ/m<sup>3</sup>, the external diameter of the burner grid should be approximately 30 mm.

**4.1.5 Gauge**, for measuring gas pressure.

**4.1.6 Draught shield**, made from asbestos-cement piping approximately 150 mm in length, 100 mm internal diameter and 110 mm external diameter. At one end the piping shall have three slots 25 mm deep in which the wire portions of the silica triangle rest (4.1.3) (see figure 3).

**WARNING — Care shall be taken not to inhale any asbestos dust.**

**4.1.7 Thermocouple**, of fine wire of diameter not greater than 0,23 mm if made of platinum or 0,45 mm if made of base metal. The ends of the couple shall be in the form of a flattened loop.

**4.1.8 Weight**, of mass 500 g.

## 4.2 Preparation of apparatus

Assemble the apparatus as shown in figure 3. Place an empty crucible (4.1.1) on the silica triangle (4.1.3) and support it in the draught shield (4.1.6). Adjust the gas and air supplies to the burner (4.1.4) so that the temperature of the inner surface of the base of the crucible reaches  $800 \pm 10$  °C in 1,5 min and  $820 \pm 5$  °C in 2,5 min from first igniting the gas.

If a Teclu type burner is used, it will generally be found that a flame approximately 300 mm long, with the crucible positioned just above the tip of the blue cone, will give the standard temperature conditions.

If a Meker type burner is used, place the crucible approximately 10 mm above the burner grid and adjust the flame so that the standard temperature conditions are attained.

Measure the temperature by means of the thermocouple (4.1.7) inserted through the pierced lid (4.1.2), and having its unprotected junction and a portion of each wire in contact with the centre of the base of the empty crucible.

Check the apparatus at frequent intervals to ensure that the standard conditions apply.

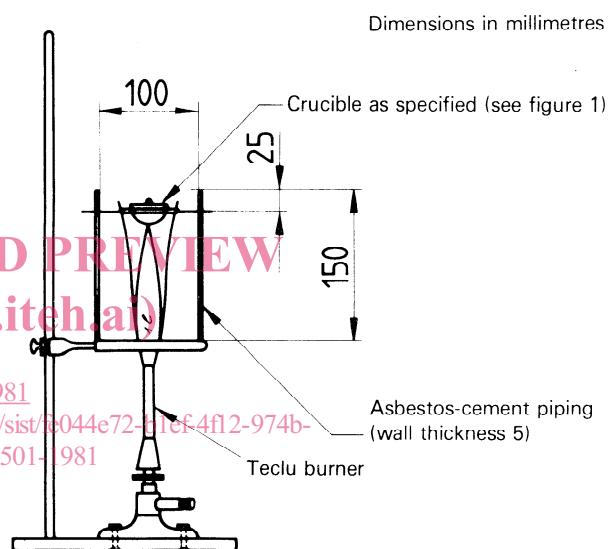

Figure 3 — Apparatus for the gas heating method

## 4.3 Procedure

Weigh 1,00 to 1,01 g of the freshly ground sample (see clause 3) into a dry crucible (4.1.1) and lightly tap the crucible about 12 times on the bench to level the surface of the coal. Cover the crucible with the unpierced lid and place it upright on the silica triangle (4.1.3) supported in the draught shield (4.1.6). Light the gas and heat at the predetermined rate for such time as is required for the flame of the burning volatile matter to die out and in any case for at least 2,5 min. Turn off the gas and allow the crucible to cool.

Remove the residue carefully from the crucible.

If the residue is non-coherent, i.e. mostly loose powder, no further examination is needed and this result shall be designated swelling number 0.

If the residue is a coherent coke button but is not swollen, place it on a flat surface and rest the 500 g weight on it. If the button supports the 500 g weight (4.1.8) without breaking into more than two or three hard pieces, designate it swelling number 1; if it crumbles, or disintegrates, then designate it swelling number 1/2.

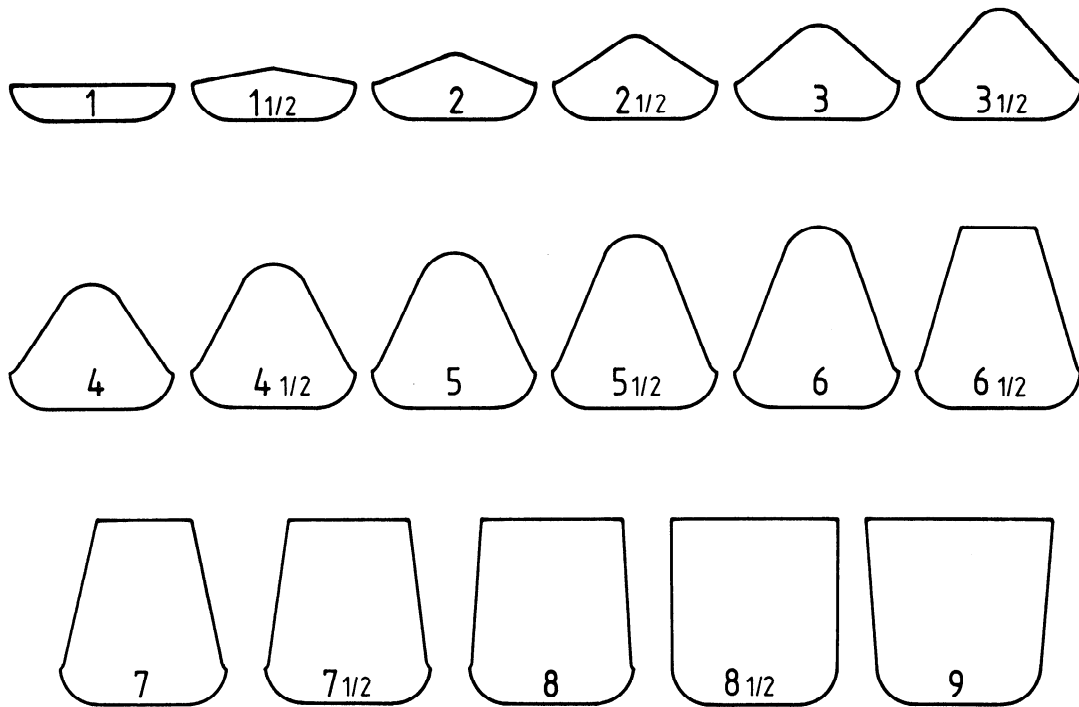

Figure 4 — Determination of crucible swelling number — Standard profiles and corresponding swelling numbers

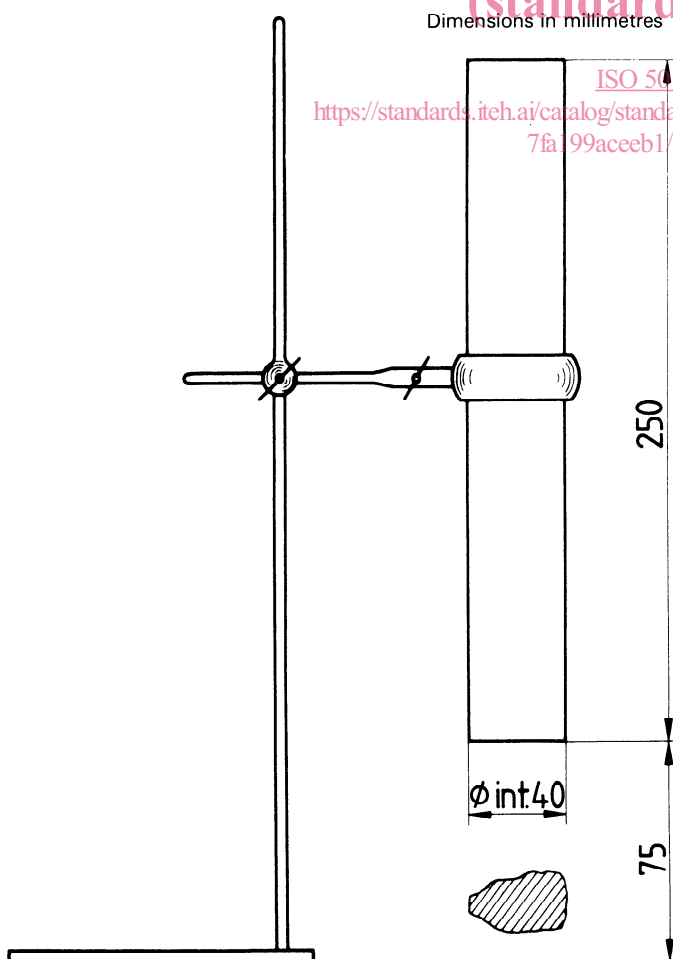

Figure 5 — Apparatus for viewing the button

If the coke button is swollen, compare it with the standard numbered profiles shown in figure 4. Rotate the button about its axis so that its largest profile is presented for comparison; designate the result by the swelling number inscribed in the outline in figure 4 which it most nearly matches. A method of viewing to avoid the effect of parallax is shown in figure 5.

Carry out five tests; after each test burn off the carbon residue and wipe the crucible with a clean cloth.

## 5 Electrical heating method

### 5.1 Apparatus

#### 5.1.1 Furnace.

A suitable type of electrically heated furnace is shown in figure 6, although other types of furnaces may be used, provided that the results obtained are the same (within 1/2 unit) as those obtained with the gas heating method.

The furnace illustrated consists of a groove refractory plate (1), approximately 88 mm in diameter and 13 mm thick, carrying the heating element, which can be a spiralled metallic coil. The plate is supported by a second grooved plate (2). An inverted silica dish (3) of 1 mm wall thickness, 10 mm high and approximately 85 mm external diameter, is placed over the windings and acts as a support for the crucible.

The plates are surrounded by a refractory cylinder (4) of approximately 140 mm diameter, bored to a depth of about 60 mm with a 90 mm diameter hole. The cylinder is fitted with a refractory lid (5), 20 mm thick; a hole 50 mm in diameter is

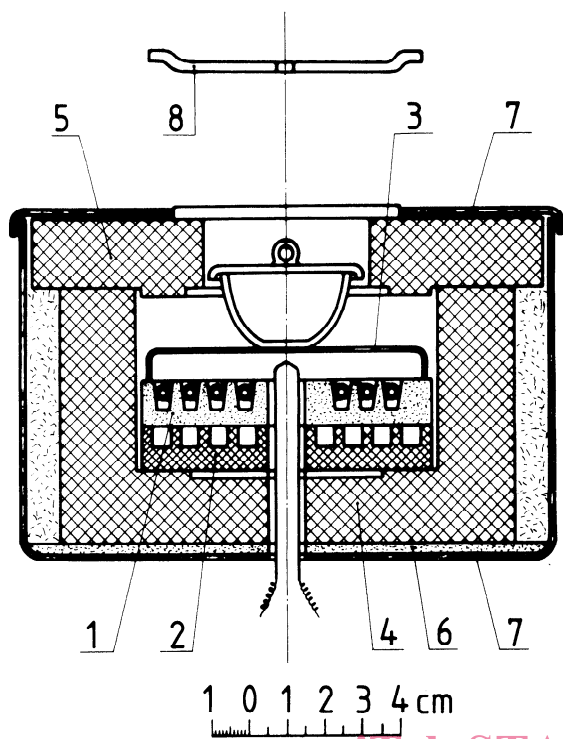

Figure 6 — Electrically heated furnace

bored in the centre of the refractory lid to allow for insertion of the crucible. The refractory cylinder rests on an asbestos sheet (6), 3 to 5 mm thick, and is surrounded by a 10 mm thick insulation of asbestos fibre and light magnesium oxide. The whole furnace is placed in an aluminium case (7).

A hole bored through the base of the furnace enables a thermocouple to be placed in contact with the underside of the silica dish.

The furnace shall be equipped with a suitable energy regulator and ammeter.

**5.1.2 Crucible and lid**, as specified in 4.1.1.

**5.1.3 Pierced silica lid**, as specified in 4.1.2.

**5.1.4 Thermocouples :**

- a) a fine wire thermocouple as specified in 4.1.7;
- b) a suitable base metal thermocouple to measure the temperature of the underside of the silica dish.

**5.2 Preparation of apparatus**

Switch on the furnace (5.1.1) and adjust the energy input so that a steady temperature of about 850 °C is maintained at the base of the crucible (5.1.2) resting on the silica plate. Remove the crucible and insert a cold crucible, covered with a pierced lid (5.1.3) through which passes the fine wire thermocouple [5.1.4 a)] held so that its unprotected junction and a portion of

each wire rests on the base of the crucible. Ascertain that the standard heating conditions of 800 ± 10 °C in 1,5 min and 820 ± 5 °C in 2,5 min are attained from the time of inserting the crucible. If these conditions are not attained, adjust the furnace temperature until the specified conditions are attained. Record the furnace temperature as indicated by the thermocouple at the underside of the silica dish, this temperature serving as a datum.

**5.3 Procedure**

Weigh 1,00 g to 1,01 g of the freshly ground sample (see clause 3) into a dry crucible (5.1.2) and lightly tap the crucible about 12 times on the bench to level the surface of the coal. Cover the crucible with the unpierced lid and place it centrally in the furnace on the silica dish. Heat until the volatile matter ceases to be evolved and in any case for at least 2,5 min.

Remove the crucible from the furnace and allow it to cool. Examine the residue as specified in 4.3.

Carry out five tests in succession, replacing one crucible with the next to avoid heat losses through the top of the furnace. Alternatively, a lid of refractory material (8) as shown in figure 6 may be used to maintain the furnace temperature between tests.

After each test burn off the carbon residue and wipe the crucible with a clean cloth.

**6 Expression of results**

Report the swelling number of the coal sample as follows :

- Swelling number 0 : non-coherent residue;
- Swelling number 1/2 : non-swollen coke button that disintegrates under the 500 g weight;
- Swelling number 1 : non-swollen coke button that supports the 500 g weight without breaking into more than two or three hard coherent pieces;
- Swelling number 1 1/2 to 9 : number of the profile in figure 4 that a swollen coke button most nearly matches.

Report the mean swelling number of the five tests to the nearest 1/2 unit.

**7 Precision of the method**

| Crucible swelling number | Maximum acceptable difference between results |  |
|--------------------------|---|--|
|                          | Same laboratory (Repeatability)               | Different laboratory (Reproducibility) |
|                          | 1 unit  | 1/2 unit                               |

### 7.1 Repeatability

The range of the results of the five tests, carried out in the same laboratory by the same operator using the same apparatus on the same analysis sample, shall not exceed the above value.

### 7.2 Reproducibility

The means of the five results obtained in each of two different laboratories on representative portions taken from the same sample after the last stage of sample preparation shall not differ by more than the above value.

## 8 Test report

The test report shall include the following particulars :

- a) an identification of the product tested;
- b) the reference of the method used;
- c) the results and the method of expression used;
- d) any unusual features noted during the determination;
- e) any operation not included in this International Standard, or regarded as optional.

## iTeh STANDARD PREVIEW (standards.iteh.ai)

ISO 501:1981

<https://standards.iteh.ai/catalog/standards/sist/fe044e72-b1ef-4f12-974b-7fa199aceeb1/iso-501-1981>

## iTeh STANDARD PREVIEW

This page intentionally left blank  
(standards.iteh.ai)

ISO 501:1981

<https://standards.iteh.ai/catalog/standards/sist/fe044e72-b1ef-4f12-974b-7fa199aceeb1/iso-501-1981>