Thermal insulation products for building applications — Determination of the resistance to impact of external thermal insulation composite systems (ETICS)

*Produits isolants thermiques destinés aux applications du bâtiment —
Détermination de la résistance au choc des systèmes d'isolation
thermique par l'extérieur (systèmes ITE)*

iTeh STANDARD PREVIEW
(standards.iteh.ai)

ISO 29803:2010

<https://standards.iteh.ai/catalog/standards/sist/92a2d697-dfd5-4057-8adb-01cbb303a8a5/iso-29803-2010>



PDF disclaimer

This PDF file may contain embedded typefaces. In accordance with Adobe's licensing policy, this file may be printed or viewed but shall not be edited unless the typefaces which are embedded are licensed to and installed on the computer performing the editing. In downloading this file, parties accept therein the responsibility of not infringing Adobe's licensing policy. The ISO Central Secretariat accepts no liability in this area.

Adobe is a trademark of Adobe Systems Incorporated.

Details of the software products used to create this PDF file can be found in the General Info relative to the file; the PDF-creation parameters were optimized for printing. Every care has been taken to ensure that the file is suitable for use by ISO member bodies. In the unlikely event that a problem relating to it is found, please inform the Central Secretariat at the address given below.

iTeh STANDARD PREVIEW
(standards.iteh.ai)

ISO 29803:2010

<https://standards.iteh.ai/catalog/standards/sist/92a2d697-dfd5-4057-8adb-01cbb303a8a5/iso-29803-2010>



COPYRIGHT PROTECTED DOCUMENT

© ISO 2010

All rights reserved. Unless otherwise specified, no part of this publication may be reproduced or utilized in any form or by any means, electronic or mechanical, including photocopying and microfilm, without permission in writing from either ISO at the address below or ISO's member body in the country of the requester.

ISO copyright office
Case postale 56 • CH-1211 Geneva 20
Tel. + 41 22 749 01 11
Fax + 41 22 749 09 47
E-mail copyright@iso.org
Web www.iso.org

Published in Switzerland

Foreword

ISO (the International Organization for Standardization) is a worldwide federation of national standards bodies (ISO member bodies). The work of preparing International Standards is normally carried out through ISO technical committees. Each member body interested in a subject for which a technical committee has been established has the right to be represented on that committee. International organizations, governmental and non-governmental, in liaison with ISO, also take part in the work. ISO collaborates closely with the International Electrotechnical Commission (IEC) on all matters of electrotechnical standardization.

International Standards are drafted in accordance with the rules given in the ISO/IEC Directives, Part 2.

The main task of technical committees is to prepare International Standards. Draft International Standards adopted by the technical committees are circulated to the member bodies for voting. Publication as an International Standard requires approval by at least 75 % of the member bodies casting a vote.

Attention is drawn to the possibility that some of the elements of this document may be the subject of patent rights. ISO shall not be held responsible for identifying any or all such patent rights.

ISO 29803 was prepared by Technical Committee ISO/TC 163, *Thermal performance and energy use in the built environment*, Subcommittee SC 1, *Test and measurement methods*.

ISO 29803 is based on EN 13497:2002 prepared by Technical Committee CEN/TC 88 *Thermal insulating materials and products*. However, (standards.iteh.ai)

- 6.2, conditioning of the test specimens, [ISO 29803:2010](https://standards.iteh.ai/catalog/standards/sist/92a2d697-dfd5-4057-8adb-01cbb303a8a5/iso-29803-2010)
- 7.1, test conditions, and <https://standards.iteh.ai/catalog/standards/sist/92a2d697-dfd5-4057-8adb-01cbb303a8a5/iso-29803-2010>
- Clause 10, test report

have been modified to reflect the conditions for tropical countries. Further, Clause 8 has been modified.

ISO 29803:2010(E)

This International Standard is based on EN 13497:2002 prepared by Technical Committee CEN/TC 88 *Thermal insulating materials and products*, which has been amended by ISO/TC 163/SC 1 with reference to conditioning and testing conditions in tropical countries.

This International Standard is one of a series of documents specifying test methods, based on existing European Standards, that are being adopted by ISO. This “package” of standards includes the following group of interrelated documents.

International Standard	Title	Respective EN standard
12968	<i>Thermal insulation products for building applications — Determination of the pull-off resistance of external thermal insulation composite systems (ETICS) (foam block test)</i>	EN 13495
29465	<i>Thermal insulating products for building applications — Determination of length and width</i>	EN 822
29466	<i>Thermal insulating products for building applications — Determination of thickness</i>	EN 823
29467	<i>Thermal insulating products for building applications — Determination of squareness</i>	EN 824
29468	<i>Thermal insulating products for building applications — Determination of flatness</i>	EN 825
29469	<i>Thermal insulating products for building applications — Determination of compression behaviour</i>	EN 826
29470	<i>Thermal insulating products for building applications — Determination of the apparent density</i>	EN 1602
29471	<i>Thermal insulating products for building applications — Determination of dimensional stability under constant normal laboratory conditions (23°C/50 % relative humidity)</i>	EN 1603
29472	<i>Thermal insulating products for building applications — Determination of dimensional stability under specified temperature and humidity conditions</i>	EN 1604
29764	<i>Thermal insulating products for building applications — Determination of deformation under specified compressive load and temperature conditions</i>	EN 1605
29765	<i>Thermal insulating products for building applications — Determination of tensile strength perpendicular to faces</i>	EN 1607
29766	<i>Thermal insulating products for building applications — Determination of tensile strength parallel to faces</i>	EN 1608
29767	<i>Thermal insulating products for building applications — Determination of short-term water absorption by partial immersion</i>	EN 1609
29768	<i>Thermal insulating products for building applications — Determination of linear dimensions of test specimens</i>	EN 12085
29769	<i>Thermal insulating products for building applications — Determination of behaviour under point load</i>	EN 12430
29770	<i>Thermal insulating products for building applications — Determination of thickness for floating-floor insulating products</i>	EN 12431
29771	<i>Thermal insulating materials for building applications — Determination of organic content</i>	EN 13820
29803	<i>Thermal insulation products for building applications — Determination of the resistance to impact of external thermal insulation composite systems (ETICS)</i>	EN 13497
29804	<i>Thermal insulation products for building applications — Determination of the tensile bond strength of the adhesive and of the base coat to the thermal insulation material</i>	EN 13494
29805	<i>Thermal insulation products for building applications — Determination of the mechanical properties of glass fibre meshes</i>	EN 13496

Thermal insulation products for building applications — Determination of the resistance to impact of external thermal insulation composite systems (ETICS)

1 Scope

This International Standard specifies equipment and a procedure for determining the resistance to impact of external thermal insulation composite systems (ETICS).

2 Normative references

The following referenced documents are indispensable for the application of this document. For dated references, only the edition cited applies. For undated references, the latest edition of the referenced document (including any amendments) applies.

ISO 29466, *Thermal insulating products for building applications — Determination of thickness*

ISO 29470, *Thermal insulating products for building applications — Determination of the apparent density*

ISO 29765, *Thermal insulating products for building applications — Determination of tensile strength perpendicular to faces*

[ISO 29803:2010](https://standards.iteh.ai/catalog/standards/sist/92a2d697-dfd5-4057-8adb-ISO 29803:2010)

<https://standards.iteh.ai/catalog/standards/sist/92a2d697-dfd5-4057-8adb-ISO 29803:2010>

EN 13499, *Thermal insulation products for buildings — External thermal insulation composite systems (ETICS) based on expanded polystyrene — Specification*

ISO 3251, *Paints, varnishes and plastics — Determination of non-volatile matter content*

ISO 9229, *Thermal insulation — Vocabulary*

3 Terms and definitions

For the purposes of this document, the terms and definitions given in ISO 9229 and EN 13499 apply.

4 Principle

The resistance to impact (impact resistance) of external thermal insulation composite systems is determined by means of a steel ball falling on to the surface of the ETICS. Any damage occurring is rated qualitatively (e.g. the reinforcement has become visible; the finishing material or the base coat has visibly delaminated or the base coat with the reinforcement has been perforated).

5 Test apparatus

For the impact resistance level of 2 J, a steel ball of (500 ± 5) g falls from a height of (408 ± 1) mm. For this, a vertical pipe with an internal diameter of at least 2 mm greater than the diameter of the steel ball and a length of 408 mm is erected above a surface of the horizontal test specimen. The ball falls through the pipe on to the surface of the test specimen (see Figure 1).

For the impact resistance level of 10 J, a steel ball of $(1\ 000 \pm 10)$ g falls from a height of $(1\ 020 \pm 1)$ mm. For this, a vertical pipe with an internal diameter of at least 2 mm greater than the diameter of the steel ball and a length of 1 020 mm is erected above a surface of the horizontal test specimen. The ball falls through the pipe on to the surface of the test specimen (see Figure 1).

Alternatively, a test apparatus as specified in ISO 7892 may be used.

6 Test specimens

6.1 Preparation and number of test specimens

The base coat with the reinforcement is applied in accordance with the manufacturer's instructions on to the surface of the thermal insulation material. The test specimens shall have minimum dimensions of 200 mm × 200 mm × 60 mm. After a time period which is specified by the manufacturer, the finishing material is applied on to the base coat in accordance with the manufacturer's instructions.

The number of the test specimens should be chosen so that five tests can be performed according to the test procedure described in 7.2.

6.2 Conditioning of test specimens

The conditioning of test specimens shall be carried out as specified in the relevant ETICS product standard.

NOTE In the absence of a product standard for ETICS or any other European technical specification, the conditioning procedure can be agreed on between the parties.

In tropical countries, different conditioning and testing conditions might be relevant. In such cases, the conditions shall be (27 ± 2) °C and (65 ± 5) % relative humidity and be stated clearly in the test report.

<https://standards.iteh.ai/catalog/standards/sist/92a2d697-dfd5-4057-8adb-01cbb303a8a5/iso-29803-2010>

7 Procedure

7.1 Test conditions

The test shall be carried out at (23 ± 2) °C and (50 ± 5) % relative humidity.

In tropical countries, different conditioning and testing conditions might be relevant. In this case, the conditions shall be (27 ± 2) °C and (65 ± 5) % relative humidity and be stated clearly in the test report.

7.2 Test procedure

For the requirement 2 J, the steel ball with 500 g falls from a height of 408 mm on to the surface of the test specimen. For the requirement 10 J, the steel ball with 1 000 g falls from a height of 1 020 mm on to the surface of the test specimen. Each test has to be performed five times on different points of the test specimen(s), and these points shall have a minimum distance of 100 mm from each other and from the edges of the specimen.

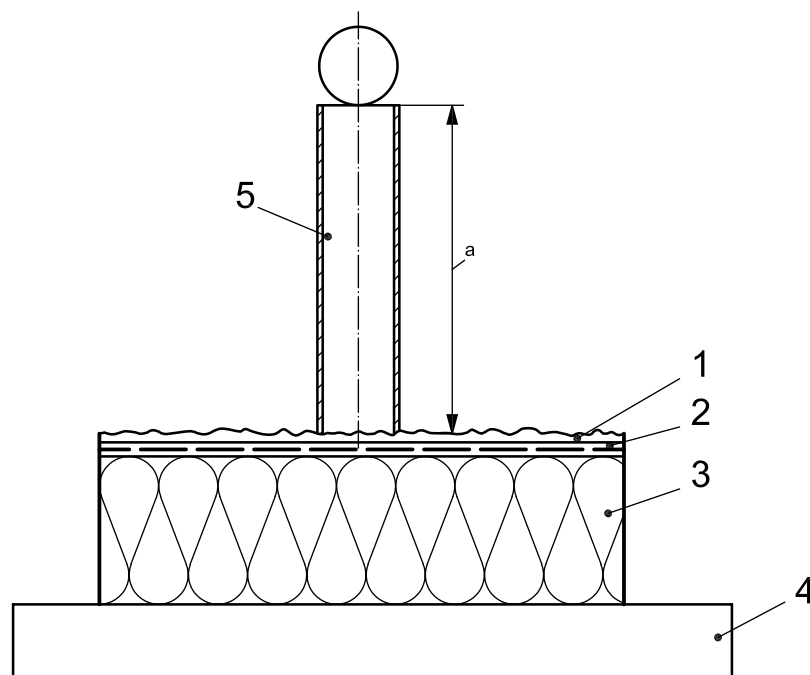
**Key**

- | | | | |
|---|---|---|-----------------------------|
| 1 | finishing material | 3 | thermal insulation material |
| 2 | base coat with reinforcement | 4 | flat and rigid surface |
| a | Height for 2 J: 408 mm;
height for 10 J: 1 020 mm. | 5 | vertical pipe |

Figure 1 — Example of a test apparatus and the test specimen for the resistance to impact

The impact resistance of ETICS may be also tested in accordance with ISO 7892. In this case, the impact body falls like a pendulum onto the specimen arranged in position in a frame. In case of rebound, the impact body shall be held back to avoid a second impact (see Figure 2).

8 Expression of results

Describe the damage observed.

The following results are considered as damage:

- the reinforcement has become visible;
- the finishing material or the base coat has visibly delaminated;
- the damage is hardly visible (slight damage), but can be felt by touching the surface;
- the base coat with the reinforcement has been perforated;
- the finishing coat has peripheral crack around the impact without damage of the base coat.

9 Accuracy of measurement

NOTE It was not possible to include a statement on the accuracy of the measurement at the time of publication of this International Standard, however, it is intended to include such a statement in future editions of this International Standard.

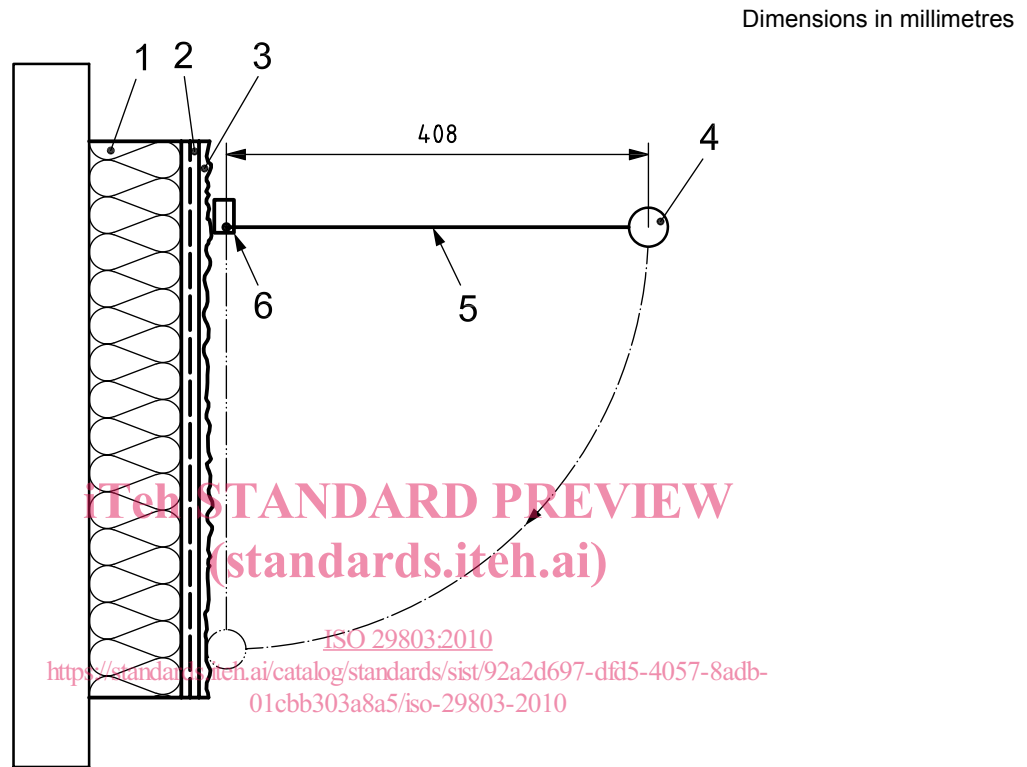

Key

- | | |
|--------------------------------|---------------------|
| 1 thermal insulation material | 4 steel ball |
| 2 base coat with reinforcement | 5 steel wire |
| 3 finishing material | 6 device for fixing |

Figure 2 — Example of a test apparatus for the resistance to impact in accordance with ISO 7892

10 Test report

The test report shall include the following information:

- a) a reference to this International Standard, i.e. ISO 29803:2010;
- b) the product identification given by the system manufacturer:
 - 1) for the ETICS:
 - i) the product name, factory, manufacturer or supplier;
 - ii) the batch numbers of the components;
 - 2) for the finishing material and base coat:
 - i) the type of product (finishing material or base coat);
 - ii) the packaging when the product arrived at the laboratory;
 - iii) the form of the product (paste or powder);
 - iv) the preparation of the product (with adding cement, water or other components, time and procedure for mixing the components before application);
 - v) the type of the main binders of the product (lime, cement, organic binder);
 - vi) the if the product is a paste, the non-volatile matter determined in accordance with ISO 3251, test conditions 3 h at 105 °C;
 - vii) the thicknesses, in millimetres, or coverage in kilogram per square metre dry weight for cement-based mortars in bags and to the paste weight for organic renders in buckets;
- 3) for the reinforcement:
 - i) the type, product name and manufacturer;
 - ii) the mass per square metre of the reinforcement, in gram per square metre;
 - iii) the thread count in warp and weft per 100 mm or mesh dimensions of the reinforcement;
- 4) for the thermal insulating material:
 - i) the type, product name and manufacturer;
 - ii) the thickness in accordance with ISO 29466;
 - iii) the declared density in accordance with ISO 29470;
 - iv) the declared tensile strength perpendicular to faces in accordance with ISO 29765;