



Designation: D 3263 – 82 (Reapproved 1999)^{ε1}

Standard Test Methods for Corrosivity of Solvent Systems for Removing Water-Formed Deposits¹

This standard is issued under the fixed designation D 3263; the number immediately following the designation indicates the year of original adoption or, in the case of revision, the year of last revision. A number in parentheses indicates the year of last reapproval. A superscript epsilon (ϵ) indicates an editorial change since the last revision or reapproval.

^{ε1} NOTE—A footnote was editorially removed in June 1999.

1. Scope

1.1 These test methods cover the determination of corrosivity of solvent systems used to remove water-formed deposits from the metal and alloy surfaces of water handling equipment. Four test methods are given as follows:

	Sections
Test Method A—Corrosivity in the Absence of Deposits	10 to 15
Test Method B—Corrosivity in the Presence of Selected Ions	16 to 21
Test Method C—Corrosivity with Magnetite-Coated Steel Specimens	22 to 28
Test Method D—Corrosivity with Deposit-Coated Specimens	29 to 35

1.2 Test Methods A and B provide for corrosivity testing under either static immersion or dynamic conditions.

1.3 Test Methods C and D are procedures applicable for corrosivity testing under static immersion conditions only.

1.4 *This standard does not purport to address all of the safety concerns, if any, associated with its use. It is the responsibility of the user of this standard to establish appropriate safety and health practices and determine the applicability of regulatory limitations prior to use.*

2. Referenced Documents

2.1 *ASTM Standards:*

D 1129 Terminology Relating to Water²

D 1193 Specification for Reagent Water²

D 2790 Test Methods of Analysis of Solvent Systems Used for Removal of Water-Formed Deposits³

3. Terminology

3.1 *Definitions:*

3.1.1 For definitions of terms used in these test methods, refer to Definitions D 1129.

3.2 *Definitions of Terms Specific to This Standard:*

3.2.1 *solvent system*—specified chemicals or combinations of chemicals, which may include corrosion inhibitors designed

to react with and remove deposits.

4. Summary of Test Methods

4.1 These test methods consist of procedures wherein the corrosivity of solvent systems is determined by the weight loss experienced by metal specimens during exposure to the solvent systems.

4.2 Test Method A is a procedure to determine corrosivity from the weight loss of metal specimens during exposure to solvent systems in the absence of deposits. This corrosivity can be determined by either static immersion or dynamic techniques.

4.3 Test Method B provides the determination in solvent systems that have had selected ions added. It describes techniques for manufacturing the solvent with the desired ions and refers to Test Method A for the actual corrosivity testing.

4.4 Test Method C describes the techniques used to produce magnetited specimens that are subsequently used for the determination of the corrosivity of the solvent system.

4.5 Test Method D describes the techniques used to produce specimens coated with a synthetic deposit that are subsequently used for the determination of the corrosivity of the solvent system.

5. Significance and Use

5.1 Test Method A is necessary because the corrosivity of a solvent system can be detrimental to the equipment being cleaned. It is used to compare the corrosivity of various solvent systems and to determine the corrosivity of selected solvent systems under different conditions.

5.2 Test Method B is necessary because the corrosivity of a solvent system can be changed by the presence of ions in the solvent system. It is used to determine if the ions that might be present during a cleaning operation would significantly change the corrosivity of a solvent system.

5.3 Test Method C is necessary because the corrosivity of a solvent system under magnetite removal conditions can be different from the corrosivity in the absence of deposit. It is used to determine the corrosivity of the solvent system under magnetite removal conditions.

5.4 Test Method D is necessary because the presence or absence of deposits may affect the corrosivity of the solvent

¹ These test methods are under the jurisdiction of ASTM Committee D-19 on Water and are the direct responsibility of Subcommittee D19.03 on Sampling of Water and Water-Formed Deposits, Surveillance of Water, and Flow Measurement of Water.

Current edition approved May 28, 1982. Published October 1982. Originally published as D 3263 – 73 T. Last previous edition D 3263 – 77.

² *Annual Book of ASTM Standards*, Vol 11.01.

³ *Annual Book of ASTM Standards*, Vol 11.02.

system. It is used to determine the corrosivity of solvent systems on deposit-coated specimens. These results are compared with results obtained from Test Method A to determine the effect of the deposit.

6. Specimen Composition and Size

6.1 Test specimens for Test Methods A, B, and C may be flat coupons, either rectangular or circular in shape, or rod or tubular material. Regardless of form, finish all specimens to a size, including edges or ends, of 38.7 cm²(6 in.²). Prepare coupon or rod specimens from hot- or cold-rolled stock, either ferrous or nonferrous, having a composition acceptable to all interested parties. Take tubular specimens from cold-drawn stock of appropriate composition; the inside diameter shall be no less than 12.7 mm (0.5 in.). Steel specimens only are used in Test Method C.

6.2 Circular coupon specimens only are used in Test Method D. They shall conform to all conditions prescribed in 6.1 except that the size shall be such that one side provides the test area of 38.7 cm²(6 in.²).

7. Specimen Preparation

7.1 Prepare four specimens of whatever form for each test condition.

7.2 Coupon Specimens:

7.2.1 Cut specimens by sawing, abrasive cut-off, or milling (shearing is not permissible). Any such power-cutting operation must include adequate cooling to prevent metallurgical changes that might result from excessive heating. Perform final mechanical finishing of the specimens, with 120-grit silicon carbide cloth. Round all edges and corners lightly. Sand blasting for finishing is not permissible. For ferrous specimens the alternative use of microglass bead blasting is permissible.

7.2.2 Drill a 3.2-mm (0.125-in.) hole near the top of rectangular specimens and through the center of circular test pieces for suspension in the solvent.

7.2.3 Mark specimens for identification by an engraving tool. (Do not identify specimens by stamping.)

7.2.4 Final preparation of the specimens shall be as follows:

7.2.4.1 Ferrous Specimens:

- (1) Degrease by immersion in acetone.
- (2) Pickle with uninhibited hydrochloric acid (HCl, 1 + 1) at room temperature for 10 min.
- (3) Neutralize by immersion in hot saturated sodium bicarbonate (NaHCO₃) solution.
- (4) Rinse with water.
- (5) Dry with acetone.

7.2.4.2 Nonferrous and Stainless Steel Specimens:

- (1) Degrease by immersion in acetone.
- (2) Scrub with household cleanser containing no oxidizing agents.
- (3) Rinse with water.
- (4) Dry with acetone.

7.2.4.3 Handle the specimens only with tongs or suitable plastic gloves during this cleaning and drying period as well as all other operations until after the final weighing following exposure to the test solvent.

7.2.4.4 Weigh each specimen to ± 1.0 mg after cooling and

store in a desiccator until ready for use. Recheck after storage for constant weight.

7.3 Rod-Type Specimens:

7.3.1 Size specimens to 12.7-mm (0.5-in.) diameter with the end rounded to a 6.35-mm (0.25-in.) radius. Perform all cutting and sizing operations by lathe turning, grinding, or milling, with adequate cooling to prevent metallurgical changes due to excessive heating. Perform final mechanical finishing of the specimen with 120-grit silicon carbide cloth.

7.3.2 Drill a 3.2-mm (0.125-in.) hole into the axial center line of one end and attach a polypropylene rod section for suspension of the specimen in the solvent with epoxy cement.

7.3.3 Mark the specimens for identification as in 7.2.3.

7.4 Tubular Specimens:

7.4.1 Perform all cutting operations by lathe turning, sawing, reaming, etc. with adequate cooling to prevent metallurgical changes. Finish both the external and internal surfaces of the tubing. Do final mechanical finishing of the specimen with 120-grit silicon carbide cloth.

7.4.2 Drill a 3.2-mm (0.125-in.) hole in each specimen near one end for suspension in the solvent.

7.4.3 Mark the specimens for identification as in 7.2.3.

7.4.4 Clean and weigh specimens as specified in 7.2.4.

8. Reagents and Materials

8.1 Purity of Reagents:

8.1.1 All solvent materials such as acids, inhibitors, and other additives shall be of commercial or technical grade, such as would normally be employed in chemical cleaning practices for the removal of water-formed deposits.

8.1.2 Reagent grade chemicals shall be used for cleaning test specimens, for addition of selected ions to solvent systems (Test Method B), preparing synthetic deposits (Test Method D), or analyzing a solvent for active components or water-formed deposit constituents. Unless otherwise indicated, it is intended that all reagents shall conform to the specifications of the Committee on Analytical Reagents of the American Chemical Society, where such specifications are available.⁴

8.2 Purity of Water— Unless otherwise indicated, references to water shall be understood to mean reagent water, conforming to Specification D 1193, Type III.

8.3 Reagents for Cleaning Specimens:

8.3.1 Acetone (CH₃COCH₃).

8.3.2 Hydrochloric Acid (1 + 1)—Carefully add 1 volume of hydrochloric acid (HCl, sp gr 1.19) to volume of water.

8.3.3 Methyl Alcohol (CH₃OH), absolute.

8.3.4 Sodium Bicarbonate Solution (100 g/L)—Dissolve 100 g of sodium bicarbonate (NaHCO₃) in water and dilute solution to 1 L.

9. Hazards

9.1 This standard may involve the use of hazardous materials, operations, and equipment. It is the responsibility of

⁴ Reagent Chemicals, American Chemical Society Specifications, American Chemical Society, Washington, DC. For suggestions on the testing of reagents not listed by the American Chemical Society, see *Analar Standards for Laboratory Chemicals*, BDH Ltd., Poole, Dorset, U.K., and the *United States Pharmacopoeia and National Formulary*, U.S. Pharmaceutical Convention, Inc. (USPC), Rockville, MD.

whoever uses this standard to establish appropriate safety practices and to determine the applicability of regulatory limitations prior to use.

TEST METHOD A—CORROSIVITY IN THE ABSENCE OF DEPOSITS

10. Scope

10.1 This test method covers the determination of corrosivity of solvent systems used to remove water-formed deposits from metal and alloy surfaces. It provides for corrosivity testing in the absence of deposit.

10.2 It provides for corrosivity testing under static immersion and dynamic conditions.

11. Summary of Test Method

11.1 This test method provides procedures for determining the corrosivity of diverse solvent systems used for the removal of water-formed deposits under three sets of conditions as follows:

11.1.1 Testing by static immersion of specimens in the solvent,

11.1.2 Testing under velocity conditions resulting from the flow of fluid past the specimens, and

11.1.3 Testing under velocity conditions resulting from the rotation of the specimens in the solvent.

11.2 The weight loss of the specimens is determined after a 6-h contact period. Other parameters such as possible solvent composition and concentration, temperature, and addition of inhibitors cover a range that cannot be standardized. Each test must be defined in terms of these variables as mutually agreed upon by all interested parties. The following temperature ranges are suggested when acidic solvents are used:

11.2.1 *Nonferrous Alloys*—37.8 to 65.6°C (100 to 150°F).

11.2.2 *Ferrous Alloys*—65.6 to 93.3°C (150 to 200°F).

11.3 Specimens for static immersion or flowing stream testing are rectangular or circular, flat coupons, rods, or tubular shapes as described in Section 6. For rotating specimen testing only the rod form is used. In all cases specimens are prepared as prescribed in Section 7.

12. Apparatus

12.1 *For Static Immersion Testing:*

12.1.1 *Constant-Temperature Bath*, thermostatically controlled to $\pm 1.1^\circ\text{C}$ (2°F) and provided with suitable openings

and supports for the test containers.

12.1.2 *Test Containers*—500-mL, tall form, lipless polypropylene beakers. They shall be fitted with tight covers.

12.2 *For Testing Under Fluid Flow Velocity Conditions:*

12.2.1 *Test Loop for Circulating Solvent* (Fig. 1), containing provisions for solvent temperature control $\pm 1.1^\circ\text{C}$ (2°F), flow control, and by-pass flow during temperature adjustment.

12.2.2 *Flow Chamber Assembly* (Fig. 2 and Fig. 3), with mounts for coupon, rod, and tubular specimens.

12.3 *For Testing Under Rotating Specimen Velocity Conditions:*

12.3.1 *Constant-Temperature Bath*—See 12.1.1.

12.3.2 *Apparatus for Rotation of Rod-Type Specimens* (Fig. 4).

13. Procedure

13.1 Prepare the test solvents using a weight-percent basis for the acid or other active material, including any additives. Only inhibitors supplied in liquid form shall be added on a volume basis prescribed by the manufacturer. The quantity of solvent prepared for static immersion and rotating specimen conditions shall be sufficient to fill essentially all test containers using four for each type of specimen-solvent combination. For fluid flow testing prepare a quantity of solvent equal to 150 % of the volume of the circulating system plus 150 mL for each specimen exposed.

13.2 *Static Immersion Test:*

13.2.1 Pour 450 mL of solvent into each test beaker (12.1.2) and place in the constant-temperature bath (12.1.1) that has been preheated to the selected test temperature. Cover the containers to avoid excessive evaporation and loss of volatile solvent components.

13.2.2 When the solvent temperature has reached that of the bath, totally immerse the test specimens, one to a container. Suspend the specimen in the solvent by a plastic-coated wire or glass hook in such a manner that contact with the container wall is avoided.

13.2.3 After a contact period of 6 h, remove the specimens and thoroughly rinse in a stream of water. Scrub the specimens with a pumice-type soap and water, using a tooth brush, or equivalent. Rinse with water, absolute methyl alcohol, and acetone, in that order, air dry, and weigh. Store in a desiccator and recheck to constant weight.

13.3 *Fluid Flow Test:*

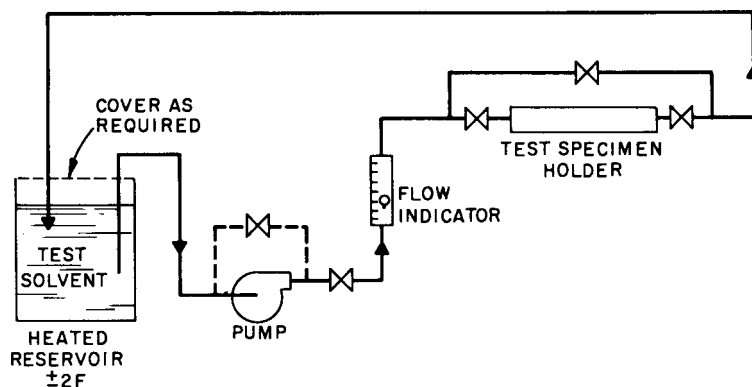

FIG. 1 Circulating Test Loop (Nonmetallic Construction)

D 3263

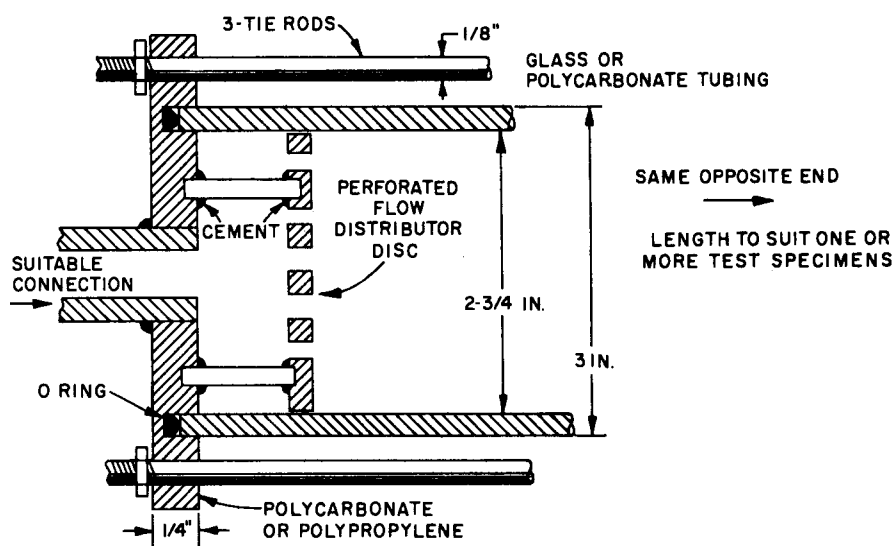

FIG. 2 Flow Chamber Test Assembly

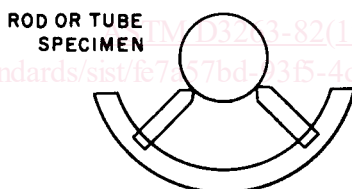
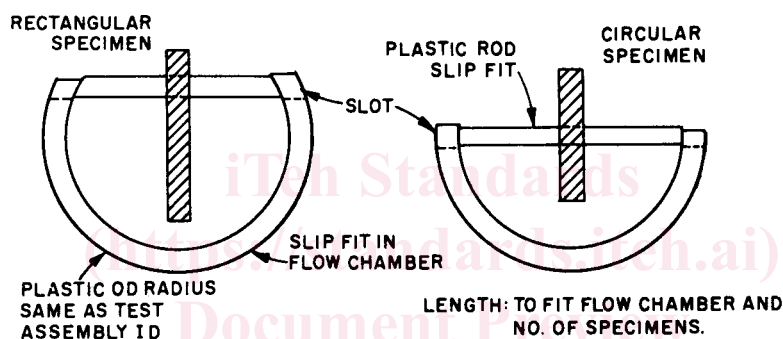

FIG. 3 Specimen Mounts for Flow Chamber

13.3.1 Fill the circulating system (Fig. 1) with solvent, start circulation, and heat, adjusting the temperature to the prescribed value.

13.3.2 When the temperature of the solvent has reached the desired temperature, mount the specimen holder. More than one specimen may be inserted in series in the test loop provided they are suitably insulated from each other. Do not test dissimilar metals at the same time.

13.3.3 Adjust the flow rate of 61 cm/s (2 ft/s) past the specimens. Other flow rates may be used by agreement when it is desired to study the effects of varying the velocity.

13.3.4 After a period of 6 h stop the circulation and remove the specimens from the solvent. Rinse, clean, and weigh in accordance with 13.2.3.

13.4 Rotating Specimen Test:

13.4.1 Pour sufficient solvent into each test container (Fig. 4) to cover the specimen fully and place in the constant-temperature bath (12.1.1), which has been adjusted to the

prescribed temperature. Cover the beakers to avoid excessive evaporation and loss of volatile constituents.

13.4.2 When the solvent in the containers has reached the prescribed temperature, submerge the specimens, connect each to a motor driven chuck, and rotate at 920 r/min approximating a surface velocity of 61 cm/s (2 ft/s). Other rotational rates may be used by agreement and expressed as equivalent velocities.

13.4.3 After a 6-h contact period remove the specimens. Rinse, clean, and weigh as directed in 13.2.3.

13.5 For additional information, the solvent concentration at the end of the test period and the amounts of any corrosion products may be determined by the appropriate procedures given in Test Methods D 2790.

14. Report

14.1 Report the corrosion rate as the milligram weight loss per 6 h. Use the average of four specimens to establish the reported value.