INTERNATIONAL STANDARD



519

INTERNATIONAL ORGANIZATION FOR STANDARDIZATION • МЕЖДУНАРОДНАЯ ОРГАНИЗАЦИЯ ПО СТАНДАРТИЗАЦИИ • ORGANISATION INTERNATIONALE DE NORMALISATION

Photography — Small flash connections for hand-held cameras — Dimensions

Photographie — Petits raccords de lampe à éclairs pour les appareils de prise de vue portatifs — Dimensions

First edition — 1974-05-01

ITeH STANDARD PREVIEW
(standards.iteh.ai)

[ISO 519:1974](#)

<https://standards.iteh.ai/catalog/standards/sist/a4f45d71-0f47-4de7-9fd4-28e16459cad8/iso-519-1974>

UDC 771.448.44 : 771.368.5

Ref. No. ISO 519-1974 (E)

Descriptors : photography, cameras, flash lamps, electric connectors, connector plugs, sockets.

Price based on 1 page

FOREWORD

ISO (the International Organization for Standardization) is a worldwide federation of national standards institutes (ISO Member Bodies). The work of developing International Standards is carried out through ISO Technical Committees. Every Member Body interested in a subject for which a Technical Committee has been set up has the right to be represented on that Committee. International organizations, governmental and non-governmental, in liaison with ISO, also take part in the work.

Draft International Standards adopted by the Technical Committees are circulated to the Member Bodies for approval before their acceptance as International Standards by the ISO Council.

Prior to 1972, the results of the work of the Technical Committees were published as ISO Recommendations; these documents are now in the process of being transformed into International Standards. As part of this process, Technical Committee ISO/TC 42 has reviewed ISO Recommendation R 519 and found it suitable for transformation. International Standard ISO 519 therefore replaces ISO Recommendation R 519-1966.

<https://standards.iteh.ai/catalog/standards/sist/a4f45d71-0f47-4de7-9fd4-4b6000000000/iso-519-1974>

ISO Recommendation R 519 was approved by the Member Bodies of the following countries :

Belgium	Italy	Sweden
Brazil	Japan	Switzerland
Canada	Netherlands	United Kingdom
Chile	New Zealand	U.S.A.
France	Romania	U.S.S.R.

The Member of the following country has subsequently approved this Recommendation :

South Africa, Rep. of

The Member Body of the following country expressed disapproval of the Recommendation on technical grounds :

Germany

Photography – Small flash connections for hand-held cameras – Dimensions

1 SCOPE AND FIELD OF APPLICATION

This International Standard specifies the dimensions of small flash connections for hand-held cameras.

2 DIMENSIONS

The dimensions shall be as shown in the figure and given in the table.

To accommodate some freedom of design and use of materials, the cone-shaped tip of the plug pin and the protruding length of socket insulation are not specifically dimensioned in this International Standard. Both influence the overall length of electrical coupling, however, and they should not be excessively long.

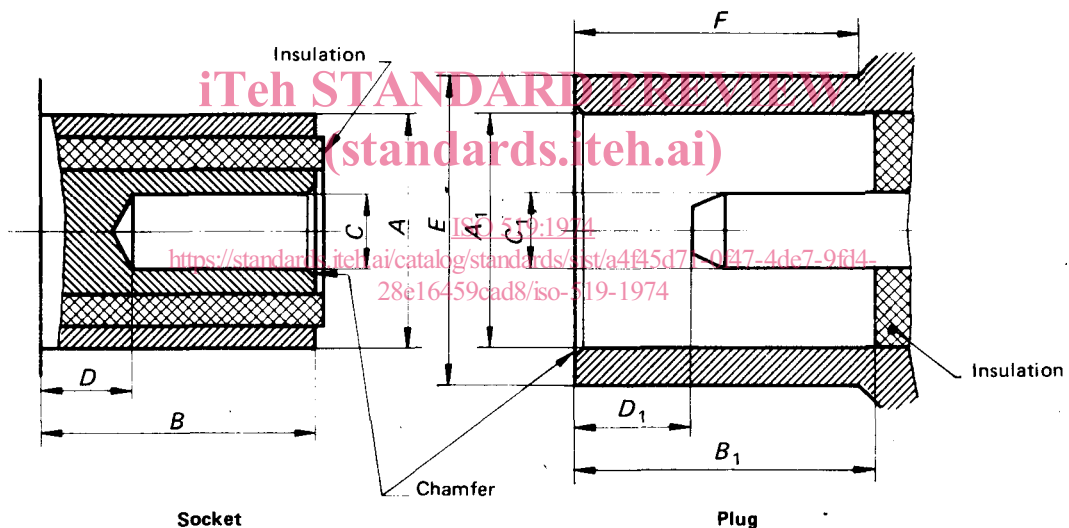

Socket			Plug		
Dimension	mm	in	Dimension	mm	in
A	3,0 ⁰ _{-0,025}	0,118 1 ⁰ _{-0,001 0}	A ₁ *	3,0	0,12
B	3,5 ± 0,2	0,14 ± 0,01	B ₁	4,0 min.	0,16 min.
C	1,003 ^{+0,025} ₀	0,039 5 ^{+0,001 0} ₀	C ₁ **	1,0 ⁰ _{-0,025}	0,039 4 ⁰ _{-0,001 0}
D	1,2 max.	0,05 max.	D ₁	1,5 ± 0,3	0,06 ± 0,01
			E	4,0 max.	0,16 max.
			F	3,5 min.	0,14 min.

* The plug bush should be fitted with a spring, such that the plug is so secured to the socket that an axial force of 4,9 to 14,7 N is required to withdraw the plug.

** To ensure good electrical contact, the inner pin should be eccentric with the outer bush.

iTeh STANDARD PREVIEW
(standards.iteh.ai)

ISO 519:1974

<https://standards.iteh.ai/catalog/standards/sist/a4f45d71-0f47-4de7-9fd4-28e16459cad8/iso-519-1974>