**Clothing for protection against heat and
flame — Determination of contact heat
transmission through protective clothing
or constituent materials —**

Part 1:

**Test method using contact heat produced
by heating cylinder**

(standards.iteh.ai)

*Vêtements de protection contre la chaleur et la flamme —
Détermination de la transmission thermique par contact à travers les
vêtements de protection ou leurs matériaux constitutifs —*

<https://standards.iteh.ai/catalog/standards/sist/59169a80-b9ac-40e5-a87d->

*Partie 1: Méthode d'essai utilisant la transmission thermique par contact
produite par un cylindre de chauffage*



PDF disclaimer

This PDF file may contain embedded typefaces. In accordance with Adobe's licensing policy, this file may be printed or viewed but shall not be edited unless the typefaces which are embedded are licensed to and installed on the computer performing the editing. In downloading this file, parties accept therein the responsibility of not infringing Adobe's licensing policy. The ISO Central Secretariat accepts no liability in this area.

Adobe is a trademark of Adobe Systems Incorporated.

Details of the software products used to create this PDF file can be found in the General Info relative to the file; the PDF-creation parameters were optimized for printing. Every care has been taken to ensure that the file is suitable for use by ISO member bodies. In the unlikely event that a problem relating to it is found, please inform the Central Secretariat at the address given below.

iTeh STANDARD PREVIEW
(standards.iteh.ai)

[ISO 12127-1:2007](https://standards.iteh.ai/catalog/standards/sist/59f69a80-b9ae-40e5-a87d-e2a03dae37b0/iso-12127-1-2007)

<https://standards.iteh.ai/catalog/standards/sist/59f69a80-b9ae-40e5-a87d-e2a03dae37b0/iso-12127-1-2007>



COPYRIGHT PROTECTED DOCUMENT

© ISO 2007

All rights reserved. Unless otherwise specified, no part of this publication may be reproduced or utilized in any form or by any means, electronic or mechanical, including photocopying and microfilm, without permission in writing from either ISO at the address below or ISO's member body in the country of the requester.

ISO copyright office
Case postale 56 • CH-1211 Geneva 20
Tel. + 41 22 749 01 11
Fax + 41 22 749 09 47
E-mail copyright@iso.org
Web www.iso.org

Published in Switzerland

Foreword

ISO (the International Organization for Standardization) is a worldwide federation of national standards bodies (ISO member bodies). The work of preparing International Standards is normally carried out through ISO technical committees. Each member body interested in a subject for which a technical committee has been established has the right to be represented on that committee. International organizations, governmental and non-governmental, in liaison with ISO, also take part in the work. ISO collaborates closely with the International Electrotechnical Commission (IEC) on all matters of electrotechnical standardization.

International Standards are drafted in accordance with the rules given in the ISO/IEC Directives, Part 2.

The main task of technical committees is to prepare International Standards. Draft International Standards adopted by the technical committees are circulated to the member bodies for voting. Publication as an International Standard requires approval by at least 75 % of the member bodies casting a vote.

Attention is drawn to the possibility that some of the elements of this document may be the subject of patent rights. ISO shall not be held responsible for identifying any or all such patent rights.

ISO 12127-1 was prepared by Technical Committee ISO/TC 94, *Personal safety — Protective clothing and equipment*, Subcommittee SC 13, *Protective clothing*.

This first edition of ISO 12127-1 cancels and replaces ISO 12127:1996, of which it constitutes a minor revision.

ISO 12127 consists of the following parts, under the general title *Clothing for protection against heat and flame — Determination of contact heat transmission through protective clothing or constituent materials*:

- *Part 1: Test method using contact heat produced by heating cylinder*
- *Part 2: Test method using contact heat produced by dropping small cylinders*

Introduction

Protective clothing designed to protect against heat and flame can be exposed to direct contact with hot substances or hot surfaces.

The diversity of such contact conditions makes it difficult to evaluate the hazards that can arise from high temperature.

The test method described in this part of ISO 12127 allows this heat transfer to be assessed when a heating cylinder and the clothing material are brought into contact with each other.

This part of ISO 12127 forms part of a series of standards concerned with clothing designed to protect against heat and fire.

iTeh STANDARD PREVIEW (standards.iteh.ai)

[ISO 12127-1:2007](https://standards.iteh.ai/catalog/standards/sist/59f69a80-b9ae-40e5-a87d-e2a03dae37b0/iso-12127-1-2007)

<https://standards.iteh.ai/catalog/standards/sist/59f69a80-b9ae-40e5-a87d-e2a03dae37b0/iso-12127-1-2007>

Clothing for protection against heat and flame — Determination of contact heat transmission through protective clothing or constituent materials —

Part 1: Test method using contact heat produced by heating cylinder

1 Scope

This part of ISO 12127 specifies a test method for the determination of contact heat transmission. It is applicable to protective clothing (including hand protectors) and its constituent materials intended to protect against high contact temperatures.

Application of this part of ISO 12127 is restricted to contact temperatures between 100 °C and 500 °C.

iTeh STANDARD PREVIEW

2 Terms and definitions (standards.iteh.ai)

For the purposes of this document, the following terms and definitions apply.

2.1 contact temperature

T_c

surface temperature of the contact area of the heating cylinder, this temperature being kept constant

2.2 start of timing

moment when the upper surface of the calorimeter and the bottom edge of the heating cylinder are within 10 mm of each other

2.3 threshold time

t_t

time between the start of timing and the moment when the temperature of the calorimeter is 10 °C above its starting value

2.4 rate of contact

relative speed with which the heating cylinder and the calorimeter with the test specimen are brought into contact with each other

2.5 contact force

force acting on the test specimen and the calorimeter when they have been brought into contact with the heating cylinder

3 Principle

The heating cylinder is heated to and maintained at the contact temperature and a test specimen is placed on the calorimeter. The heating cylinder is lowered onto the test specimen supported by the calorimeter or, alternatively, the calorimeter with the specimen is lifted up to the heating cylinder. In either case, the operation is carried out at a constant speed. The threshold time is determined by monitoring the temperature of the calorimeter.

4 Apparatus

4.1 Heating cylinder

The heating cylinder shall be constructed from a suitable metal which can withstand temperatures of over 500 °C (e.g. pure nickel). Figure 1 shows an example of the heating cylinder. The contact surface shall have a diameter of $(25,2 \pm 0,05)$ mm and shall be surface ground. There shall be a central boring which ends 3 mm above the lower surface of the heating cylinder. This boring is intended to hold the temperature sensor, which is necessary for regulation of the temperature of the heating cylinder, and its diameter should be chosen accordingly. A helical slot of depth D , width B and pitch Z shall be machined in the upper part of the heating cylinder. The values of D , B and Z shall be chosen in such a way that the total heated length of a heating conductor can be placed in the slot. The heating cylinder shall be enclosed by heat-resistant insulation, leaving free the bottom contact surface.

4.2 Calorimeter

The calorimeter (as shown in Figure 2) consists of a cylindrical disc of black anodized pure aluminium of $(25 \pm 0,05)$ mm diameter and $(5 \pm 0,02)$ mm thickness, which is fixed on a mounting made from polyamide 66. The upper contact surface of the calorimeter shall be surface ground before anodization and on the lower surface a temperature sensor (e.g. platinum resistor) shall be fixed.

<https://standards.iteh.ai/catalog/standards/sist/59f69a80-b9ae-40e5-a87d-e2a03dae37b0/iso-12127-1-2007>

4.3 Assembly

Figure 3 shows an example of the assembly. The heating cylinder and calorimeter are mounted with parallel faces and with their symmetrical axes in line in a supporting frame. Provision shall be made for moving at a controlled speed either the heating cylinder down towards the calorimeter or the calorimeter up towards the heating cylinder. The additional weight shall be dimensioned in such a way that the contact force is $(49 \pm 0,5)$ N. Between measurement, during cooling periods, a suitable shielding shall be put between the heating cylinder and the calorimeter in order to prevent the calorimeter from being heated by thermal radiation from the heating cylinder.

4.4 Electronic devices

Suitable electronic devices shall be provided to

- heat the heating cylinder to at least 500 °C and to maintain the temperature;
- control the rate of contact;
- measure and register the calorimeter temperature to an accuracy of $\pm 0,1$ °C;
- measure the threshold time.

5 Sampling and conditioning

5.1 Sampling

At least three circular test specimens of 80 mm diameter shall be taken for each contact temperature from the product or from a piece of the material intended for manufacture of the product.

5.2 Conditioning

Before the test, the test specimens shall be conditioned for at least 24 h in an atmosphere having a temperature of (20 ± 2) °C and relative humidity of (65 ± 5) %.

6 Test method

6.1 Starting conditions

The measurements shall be carried out in an atmosphere having a temperature of (20 ± 5) °C and relative humidity between 15 % and 80 %. The heating cylinder shall be brought to ± 2 % of the selected contact temperature (in degrees Celsius). The temperature of the calorimeter shall be at room temperature ± 2 °C before the start of each test. The test shall be started not later than 3 min after the test specimen has been taken out of the conditioning atmosphere (see 5.2).

6.2 Procedure

Place the test specimen on the calorimeter so that its outer face is upwards. Remove the shielding between the heating cylinder and the calorimeter and bring the heating cylinder into contact with the calorimeter with a rate of contact of $(5,0 \pm 0,2)$ mm/s. Measure and record the temperature of the calorimeter during the test. Carry out at least three measurements at each contact temperature.

6.3 Evaluation

Determine the threshold time, t_t , to the nearest 0,1 s.

7 Test report

The test report shall contain the following elements:

- a) reference to this part of ISO 12127;
- b) name of the supplier of the product or material;
- c) name, as given by the supplier, and description of the product or material;
- d) contact temperature(s), T_c ;
- e) threshold time, t_t (individual values or, if five or more measurements per contact temperature have been made, the mean value and standard deviation);
- f) description of observed changes in the test specimens;
- g) date of test;
- h) any deviation from the test method specified in this part of ISO 12127.

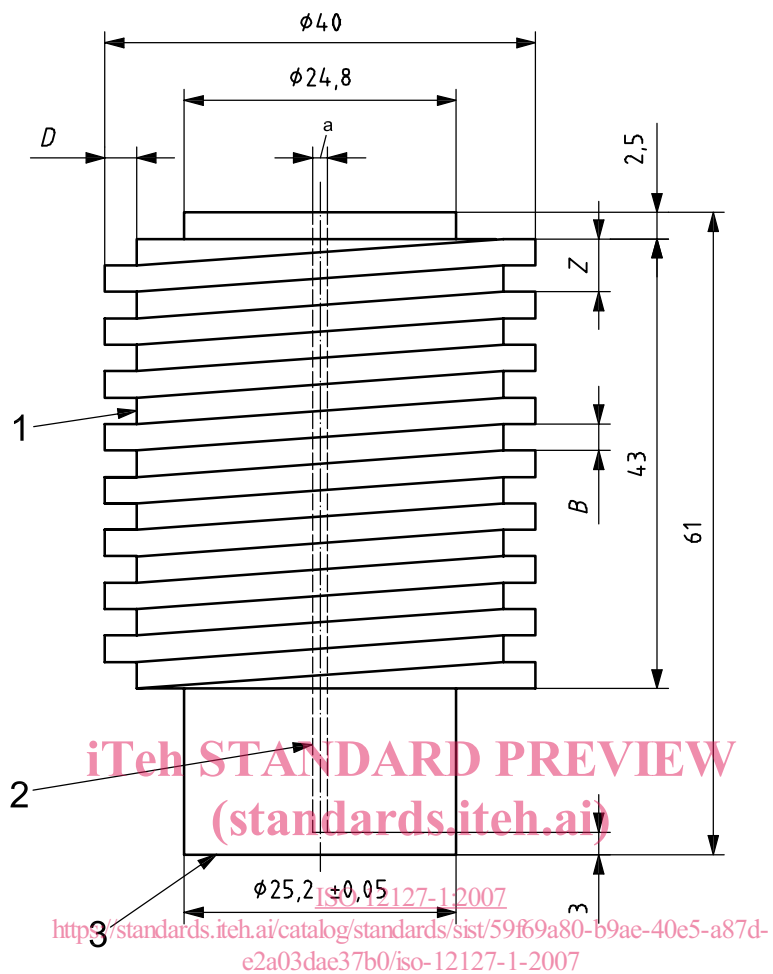

Key

- 1 slot for the heating conductor
- 2 boring for temperature sensor
- 3 contact surface
- B* width of helical slot
- D* depth of helical slot
- Z* pitch of helical slot
- a* Diameter of the boring appropriate for the temperature sensor.

Figure 1 — Heating cylinder

Dimensions in millimetres

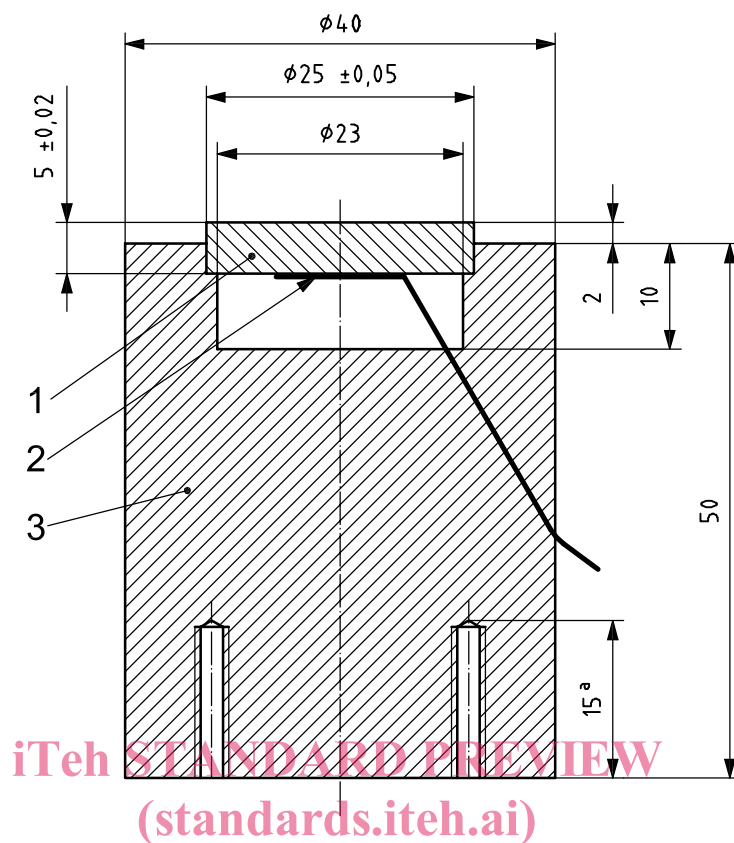
**Key**

- 1 cylindrical disc, made from black anodized pure aluminium
 2 temperature sensor, e.g. platinum resistor
 3 mounting, made from polyamide 66
 a Maximum depth of thread holes for mouting the calorimeter.

Figure 2 — Calorimeter