



Designation: ~~D1761-88~~ (Reapproved 2000)^{e1} Designation: D 1761 – 06

Standard Test Methods for Mechanical Fasteners in Wood¹

This standard is issued under the fixed designation D 1761; the number immediately following the designation indicates the year of original adoption or, in the case of revision, the year of last revision. A number in parentheses indicates the year of last reapproval. A superscript epsilon (ϵ) indicates an editorial change since the last revision or reapproval.

This standard has been approved for use by agencies of the Department of Defense.

^{e1}Note—1 1/4 in. was corrected to 1 1/4 in. in 8.1.1 in October 2002.

INTRODUCTION

The use of wood and wood-base materials in many structural and other applications often involves the use of mechanical fasteners, such as nails, screws, bolts, lag screws, and connectors. Data on the strength and performance of such fasteners are frequently needed for design and for comparative purposes. Tests of mechanical fasteners (except nail withdrawal) have been generally regarded as special tests and have not been included in the standard methods already established for evaluating the properties of wood. Many such special tests have been extensively used over a considerable period but have not previously been established as standards. Presented herewith are methods of conducting tests for nail, staple, and screw (except machine screws) withdrawal resistance; lateral load transmission by nail, staple, screw, bolt, and timber connector; and load transmission by nail plates and joist hangers. plates. The use of standard methods for these tests is recommended as a means of obtaining comparable data and of eliminating variables in test results because of variations in testing methods.

The tests appear in the following order:

Nail, Staple, or Screw Withdrawal Test	Sections
Lateral Nail, Staple, or Screw Resistance Test	1 to 12
Testing Bolted and Timber Connector Joints	13 to 20
Tension Tests of Plate-Type Connector Joints	21 to 30
Joist Hanger Tests	31 to 40
Precision and Bias	41 to 50
Precision and Bias Keywords	51
	41

NAIL, STAPLE, OR SCREW WITHDRAWAL TEST

1. Scope

1.1 These test methods provide a basic procedure for evaluating the resistance of wood and wood-base materials to direct withdrawal of nails, staples, and screws. Spikes are included as nails in this standard.

1.2 The tests also provide a basis for determining comparable performance of different types and sizes of nails, staples, and screws in direct withdrawal from wood and wood-base materials.

1.3 *This standard does not purport to address all of the safety problems, if any, associated with its use. It is the responsibility of the user of this standard to establish appropriate safety and health practices and determine the applicability of regulatory limitations prior to use.*

2. Referenced Documents

2.1 *ASTM Standards:*²

D 143 [Test Methods of Testing for Small Clear Specimens of Timber](#)

D 2016 [Test Methods for Moisture Content of Wood](#)³

¹ These test methods are under the jurisdiction of ASTM Committee D07 on Wood and are the direct responsibility of Subcommittee D07.05 on Wood Assemblies. Current edition approved December 30, 1988. Published March 1989. Originally published as D1761—60F. Last previous edition D1761—77(1988).

Current edition approved March 1, 2006. Published March 2006. Originally approved in 1960. Last previous edition approved in 2000 as D 1761 — 88 (2000)^{e1}.

² Annual Book of ASTM Standards, Vol 04.10.

³ For referenced ASTM standards, visit the ASTM website, www.astm.org, or contact ASTM Customer Service at service@astm.org. For Annual Book of ASTM Standards volume information, refer to the standard's Document Summary page on the ASTM website.

^{e1} Discontinued, see 1988 Annual Book of ASTM Standards, Vol 04.09.

D 2395 Test Methods for Specific Gravity of Wood and Wood-Based Materials

E 4 Practices for Force Verification of Testing Machines

2.2 Other Standards:

Federal Specification FF-W-92 for Washers, Metal, Flat (Plain)⁴

ANSI B18.6.1 American National Standard for Slotted and Recessed Head Wood Screws⁵

3. Summary of Test Method

3.1 Specimens consist of prisms of wood or wood-base products, with nails, staples, or screws driven at right angles to one or more faces. The fasteners are withdrawn at a uniform rate of speed by means of a testing machine, and the maximum load is recorded. Supplementary physical properties of the wood or wood-base product are also determined.

4. Significance and Use

4.1 The resistance of a species of wood or a wood-base product to direct withdrawal of nails, staples, or screws is a measure of its ability to hold or be held to an adjoining object by means of such fasteners. Factors that affect this withdrawal resistance include the physical and mechanical properties of the wood; the size, shape, and surface condition of the fasteners; the speed of withdrawal; physical changes to wood or fasteners between time of driving and time of withdrawal; orientation of fiber axis; and the occurrence and nature of prebored lead holes.

4.2 By using a standard size and type of nail, staple, or screw, withdrawal resistance of a wood species or wood product can be determined, and such values for two or more wood species or wood products can be compared. Throughout the method this is referred to as the basic withdrawal test. Similarly, comparative performances of different sizes or types of nail, staple, or screw can be determined by using a standard procedure with a particular wood or wood product, which eliminates the wood or the wood product as a variable. Since differences in test methods can have considerable influence on results, it is important that a standard procedure be specified and adhered to, if test values are to be related to other test results.

5. Apparatus

5.1 *Testing Machine*—Any suitable testing machine that is capable of operation at a constant rate of motion of the movable head and has an accuracy of $\pm 1\%$ when calibrated in accordance with Practices E 4.

5.2 *Grips*—A gripping device shaped to fit the base of the fastener head and of such a design as to allow accurate specimen positioning and true axial loading, is required. A clamping assembly that will hold the specimen to one platen of the machine is also required. A suitable test mechanism for screw withdrawal is illustrated in Fig. 1.

6. Test Materials

6.1 Nails:

6.1.1 Nails used for basic withdrawal tests shall be bright plain-shank diamond-point round-wire, low-carbon-steel nails nominally 0.113 in. (2.87 mm) diameter (Note 1). They shall be cleaned before use to remove any coating or surface film that may be present as a result of manufacturing operations and exposure. Each nail shall be used but once.

³ Withdrawn.

⁴ Annual Book of ASTM Standards, Vol 03.01.

⁴ Available from Standardization Documents Order Desk, DODSSP, Bldg. 4, Section D, 700 Robbins Ave., Philadelphia, PA 19111-5098.

⁵ Available from Standardization Documents Order Desk, Bldg. 4 Section D, 700 Robbins Ave., Philadelphia, PA 19111-5094, Attn: NPODS.

⁵ Available from American National Standards Institute (ANSI), 25 W. 43rd St., 4th Floor, New York, NY 10036.

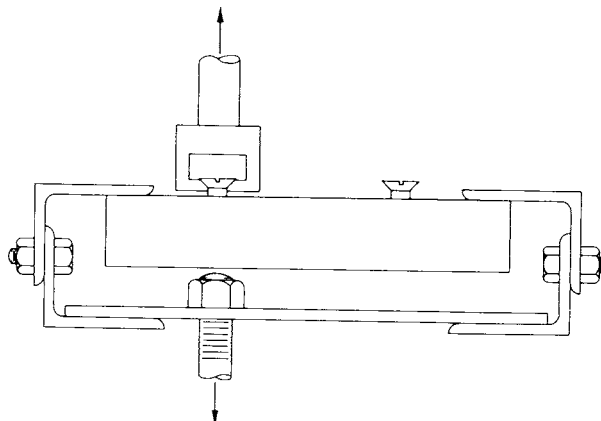

FIG. 1 Diagram of Assembly for Screw Withdrawal Test

NOTE 1—A sixpenny common wire nail meets this requirement.

6.1.2 For determining holding ability of different sizes or types of nails in wood or wood products, the respective sizes and types of nail will be as circumstances dictate. These nails shall be representative of the normal manufacturing process, and special cleaning of the shank shall normally not be undertaken.

6.2 Staples:

6.2.1 Staples used for basic leg withdrawal resistance shall be standard 2 in. (51 mm) long, $\frac{7}{16}$ in. (11.1 mm) crown, 15 gage (0.072 in.) (1.83 mm) galvanized steel staples. They shall be cleaned before use. Each staple shall be used but once.

6.2.2 For determining holding ability of different types or sizes of staples in wood or wood products, the respective staples shall be representative of the normal manufacturing process, and special cleaning of the legs shall not normally be undertaken.

6.3 Screws:

6.3.1 Screws used for basic withdrawal tests shall be standard 1-in. (25 mm) No. 10-gage flathead low-carbon-steel wood screws as described in the American National Standard for Slotted and Recessed Head Wood Screws (ANSI B18.6.1). Each screw shall be used but once.

6.3.2 For determining holding ability of different sizes and types of screws in wood or wood products, the respective size and types of screw will be as circumstances dictate. These screws shall be representative of the normal manufacturing process.

6.4 *Wood and Wood Products*—Prisms shall be cut accurately and square to the required dimensions, and be planned smooth. They shall be of representative density, free of defects and growth irregularities, and of specified moisture content.

7. Sampling

7.1 Sampling should provide for selection of representative test material on an objective and unbiased basis, covering an appropriate range in density and properties as circumstances suggest.

7.2 The tests should be sufficiently extensive to provide reliable results. Where analysis by statistical procedures is contemplated, experience and sometimes advance estimates can be used to establish the scope of testing and type of sampling needed to achieve the expected reliability.

NOTE 2—The precision required, and thus the manner of sampling and number of tests, will depend upon specific objectives. No specific criteria therefore can be established. General experience indicates that the coefficient of variation from tests of fasteners ranges from about 15 to 30 %. When such is the case, precision of 5 to 10 %, with 95 % confidence (an often accepted general measure of reliability for testing wood) cannot be achieved without making a rather large number of tests. The present recommendation is to make at least 10 replications for each variable as a minimum requirement.

8. Test Specimen

8.1 *Nail and Staple Withdrawal* :

8.1.1 For basic withdrawal tests from wood, the wood prism shall be 2 by 2 by 6 in. (51 by 51 by 152 mm). Nails of the type outlined in 6.1.1 and staples of the type outlined in 6.2.1 shall be driven at right angles to the face of the specimen to a total penetration of $1\frac{1}{4}$ in. (32 mm). Two fasteners shall be driven into a tangential surface, two into a radial surface, and one into each end. End and edge distances shall be sufficient to avoid splitting. In general, edge distances should not be less than $\frac{3}{4}$ in. (19 mm), end distances not less than $1\frac{1}{2}$ in. (38 mm) and two fasteners shall not be driven in line with each other or less than 2 in. (51 mm) apart on radial or tangential faces. Nails shall be driven manually with a hammer. Staples shall be inserted with an appropriate tool, as nearly as possible perpendicular to the specimen surface, with the staple crown at a $45^\circ (\pm 10^\circ)$ angle to the grain direction of the prism.

8.1.2 For basic withdrawal tests from wood products, the test prism shall be a single thickness of convenient size not smaller than 3 in. (76 mm) wide and 6 in. (152 mm) long. Nails of the type outlined in 6.1.1 and staples of the type outlined in 6.2.1 shall be driven through the wood product at right angles to the face, permitting at least $\frac{1}{2}$ in. (13 mm) of the shank portion to remain above the surface. Nails shall be driven manually by means of a hammer. Staples shall be inserted with an appropriate tool as in 8.1.1, but if there is no discernible grain direction in the wood product, the staple crown shall be oriented at a $45^\circ (\pm 10^\circ)$ angle to the length of the prism.

8.1.3 For determining the withdrawal resistance of particular sizes and shapes of nails or staples in wood or wood products, the specimen shall be of convenient size to accommodate the quantity of fasteners to be tested in each specimen, without exceeding the edge and end distances and spacings necessary to avoid splitting. In wood, fasteners should be driven to 70 % of their length; in thin panel wood products they should be driven completely through the thickness with at least $\frac{1}{2}$ in. (13 mm) of the shank portion remaining above the surface. The fasteners shall be driven by the method intended to be used in practice, that is, either manually with a hammer, or with an applicator or appropriate tool if this is the normal method.

8.1.3.1 If the withdrawal resistance may be influenced by the material through which the fastener is to be driven, the fastener shall be driven through the fastened member (cleat) into the fastening member.

8.2 *Screw Withdrawal*:

8.2.1 For basic withdrawal tests from wood, the specimen shall be 2 in. (51 mm) wide, 6 in. (152 mm) long, with depth at least equal to the length of the screw. Two screws of the type outlined in 6.2.1 shall be threaded into lead holes at right angles to the tangential face, to a total penetration equal to the length of the threaded portion. End and edge distance shall be sufficient to avoid splitting, which in general will be at least $\frac{3}{4}$ in. (19 mm) from the edge and $1\frac{1}{2}$ in. (38 mm) from the end, and spacing will be

at least 2½ in. (63 mm). The size of the lead hole shall be 70 % of the root diameter of the screw for softwoods and hardwoods and shall extend ½ in. (13 mm) into the face of the specimen. The screws may be coated with paraffin wax or other similar lubricant when necessary to facilitate driving.

8.2.2 For basic withdrawal tests from wood products, the specimen shall be 3 in. (76 mm) in width, and 6 in. (152 mm) in length. The depth of the specimen shall be at least equal to the length of the screw, and it may be necessary to glue together two or more thicknesses of material to provide the required depth. Screws of the type outlined in 6.2.1 shall be threaded into the specimen a distance of ⅔ in. (17 mm) at midwidth, at least 2 in. (51 mm) from the end of the specimen. The size of lead hole shall be 70 % of the root diameter of the screw and it shall extend ½ in. (13 mm) into the face of the specimen. The screws may be coated with paraffin wax or other similar lubricant when necessary to facilitate driving.

8.2.3 For determining the withdrawal resistance of particular sizes and types of screws in wood or wood products, the specimen shall be of convenient size to accommodate the quantity of screws to be tested in each specimen, without exceeding the edge and end distances and spacings necessary to avoid splitting. Screws shall be threaded into the specimen for the length of the threaded portion of the shank or two thirds of the shank length if it is threaded throughout. The size of lead hole, if one is to be drilled, shall be 70 % of the root diameter of the screw for a distance of one half of the screw length.

8.2.3.1 If the withdrawal resistance may be influenced by the material through which the screw is to be threaded the screw shall be threaded through a held member into the holding member.

9. Conditioning

9.1 Nail, staple, and screw withdrawal tests are normally made on seasoned material. The wood or wood product, whether kiln dried or air-dried, shall be stored in a room having a controlled temperature of $20 \pm 3^\circ\text{C}$ ($68 \pm 6^\circ\text{F}$) and a controlled relative humidity of $65 \pm 3\%$ for a period sufficiently long to bring it to approximate equilibrium. The fasteners shall not be driven until equilibrium is attained in the wood component.

9.2 Where required, withdrawal tests may be made on drier, partially seasoned or unseasoned material. It may sometimes be desired to apply the fasteners to unseasoned material and allow the completed specimen to season prior to withdrawal. As in 9.1 these specimens should attain the desired moisture equilibrium in a controlled atmosphere to ensure uniform moisture content at the time of test. Soaking in water will produce and maintain an unseasoned condition of the wood, but it may result in an extremely high moisture content, particularly at the surface, and undesirable and nonrepresentative corrosion of the fasteners near the wood surface.

10. Procedure

10.1 *General*—Except for special circumstances requiring delayed withdrawal, withdraw fasteners as quickly as practical after driving, and in all cases within 1 h.

10.2 Basic Loading Method:

10.2.1 Where the specimen consists of only the fastening prism and the fasteners, withdraw the fasteners by means of a tensile force applied at a uniform rate of withdrawal. Attach the specimen to one platen of the testing machine. Attach the fastener head to a suitably designed grip which is fastened to the other platen through a universal joint. Apply the load by separation of the platens of the testing machine at a uniform rate of withdrawal. Read the maximum load required to withdraw the fastener from the wood or wood product to three significant figures. Disregard test values resulting from any failure of the fastener in the evaluation of the performance of wood and wood-base materials but report them; consider such failures in the evaluation of the performance of different types and sizes of fasteners. In such cases, an additional replication is desirable.

10.2.2 Where the specimen consists of a fastening prism plus one or more (cleats) fastened thereto with a fastener, two test procedures are possible: (a) The fastened member can be grasped and pushed or pulled away from the fastening prism in the axial direction of the fastener, whereby the fastener head exerts a force on the fastened member. Under this procedure, if the fastened member exerts less resistance to the passage of the fastener head than the fastening member exerts on fastener withdrawal head pull-through can occur. In such a case, the pull-through resistance of the fastened material will be indicated. (b) The fastened member can be split off and the fastener withdrawn as in 10.2.1.

10.3 *Special Loading Methods*—It may sometimes be necessary to determine the resistance to withdrawal as a result of an impact force or by repetitive loads. In the case of the former, this can be accomplished with standard apparatus such as the U.S. FPL toughness testing machine suitably modified to hold and grip the withdrawal specimen. The latter test may require the use of a cycling or pulsating loading head. The resulting data are based on the displacement angle of the pendulum and the forces resulting from the setting of the repetitive loading mechanism, respectively, required to withdraw the fastener from the wood or wood product. Disregard test values resulting from any failure of the fastener in the evaluation of the performance of wood and wood-base materials but report if desired; consider such failures in the evaluation of the performance of different types and sizes of fasteners. In such cases, an additional replication is desirable.

10.4 Speed of Testing:

10.4.1 For the basic loading method for fastener withdrawal, apply the load throughout the test at a uniform rate of platen separation of 0.10 in. (2.54 mm)/min $\pm 25\%$.

10.4.2 For special loading methods, special rates of withdrawal may be required. Record the rate used and the reasons for choosing it in the report.

NOTE 3—The rate of platen separation shall mean the free-running, or no-load, crosshead speed for testing machines of the mechanical drive type, and the loaded crosshead speed for testing machines of the hydraulic loading type.

10.5 *Supplementary Tests*—If information on the actual withdrawal during load application is desired or may be of influence on the interpretation of the withdrawal resistance of a given fastener, measure and record such withdrawal, in inches, at given withdrawal loads or at the ultimate withdrawal resistance, in pounds, to three significant numbers. Under given conditions, it may be expeditious to obtain an automatic plot of withdrawal load versus withdrawal distance in order to determine the stiffness of the joint and the work involved up to a given point of withdrawal of the fastener under construction.

10.6 *Minor Tests*—Determine the oven-dry specific gravity and moisture content of the wood or wood products, both during driving and withdrawal of the fastener. Procedures for determining these properties are given in Test Methods D 2016 and D 2395.

11. Report

11.1 The report shall include the following:

11.1.1 Failure loads for individual fasteners, average test values, and statistical evaluation of the test data if justified,

11.1.2 A complete description of the test method and loading procedure used,

11.1.3 A description of the specimen, including the dimensions of the wood or wood-product components, size of fastener, end and edge distances, and spacings,

11.1.4 Number of tests,

11.1.5 Specific gravity and moisture content of wood components,

11.1.6 Details of any deviations from the prescribed or recommended methods as outlined in the standard, and

11.1.7 Details of any factors not included above that might have a bearing on results.

12. Precision and Bias

12.1 The precision and bias of this test method have not yet been determined.

LATERAL NAIL, STAPLE, OR SCREW RESISTANCE TEST

13. Scope

13.1 This test method covers the determination of the resistance to lateral movement offered by a single nail, staple, or screw in wood members. The test provides comparative data for various species of wood. This general test method can also be used for evaluating other types and sizes of fastenings either in wood or other building materials such as plywood, hardboard, etc., or combinations of materials. Furthermore, where required for specific purposes, the general method can be used for evaluating the lateral resistance of sizes of nails, staples, and screws other than those specified, and joints employing two or more fasteners. It is recommended that when such tests are made, the specified procedure be followed as closely as possible and all deviations be completely described.

14. Test Nails, Staples, or Screws

14.1 Nails used shall be bright plain-shanked medium diamond-point steel nails nominally 0.131 in. (3.33 mm) in diameter and 2½ in. (63 mm) in length, with a head ⅜ in. (7.14 mm) in diameter. The nails selected for test shall be representative of the product. Each nail shall be used only once. The actual size and details of the nails selected shall be recorded, including data on the properties of the metal.

NOTE 4—An eightpenny common wire nail meets this requirement.

14.2 Staples used shall be standard 2 in. (51 mm) long ⅞ in. (11.1 mm) crown, 15 gage (0.072 in.) (1.83 mm) galvanized steel staples. They shall be representative of the product. Each staple shall be used but once. Actual size and details of the staple used shall be recorded.

14.3 Screws used shall be standard 2½-in. (63 mm) No. 10-gage flathead steel wood screws as described in American National Standard for Slotted and Recessed Head Wood Screws (ANSI B18.6.1). Each screw shall be used only once. The screws shall be selected to be representative of the type chosen for test.

15. Sampling

15.1 Tests shall be made using clear, straight-grained representative material. The two pieces of wood used for test (cleat and prism) shall be of end- or side-matched flatsawn material. Whenever possible, the sampling shall be on a statistical basis, and the tests shall be sufficient in number to permit a statistical analysis.

NOTE 5—The precision required and thus the manner of sampling and the number of tests will depend upon the specific objective of the investigation. No general criteria, therefore, can be established. However, experience has indicated that at least five specimens per variable are required as a minimum to give generally acceptable results. A larger number is desirable.

16. Test Specimen

16.1 The size of the specimen that receives the point of the fastener (prism) shall be 2 in. (51 mm) thick, 2 in. (51 mm) wide, and 12 in. (300 mm) long. The size of the specimen through which the fastener is driven (cleat) shall be 2⁵/₃₂ in. (20 mm) thick,

2 in. (51 mm) wide, and 12 in. (300 mm) long. The actual dimension of each piece shall be determined.

16.2 The test specimen shall be assembled by overlapping the ends of the 2-in. (50 mm) wide cleat and prism members by a distance of 4 in. (100 mm), thus forming a test specimen with a total length of 20 in. (500 mm). The test fastener shall be inserted at the center of the width of the cleat and the prism and 2 in. (50 mm) from the overlapping end of each. The prism shall be oriented to permit the insertion of the test fastener into a tangential face. A bolt hole $\frac{3}{4}$ in. (19 mm) in diameter shall be bored at the center of the width and 2 in. (50 mm) from each end of the specimen to accommodate the loading fixtures.

16.3 When testing with a nail, the top of the nailhead shall be driven flush with the surface. The nail shall be driven as nearly perpendicular to the specimen surface as possible.

16.4 When testing with a staple it shall be inserted with an appropriate tool as nearly as possible perpendicular to the specimen surface with the staple crown at a $45^\circ (\pm 10^\circ)$ angle to the grain direction of the fastened and fastening wood members. When evaluating wood products, if there is no discernible grain direction in the wood product, the staple crown shall be oriented at a $45^\circ (\pm 10^\circ)$ angle to the length of the fastening member. All staples shall be driven flush or slightly ($\frac{1}{16}$ in.) (1.6 mm) countersunk. Collated staples shall not be cleaned.

16.5 When testing with a screw, the screw shall be inserted with a screw driver through prebored lead holes, which are as nearly perpendicular to the specimen surface as possible. The lead hole in the cleat shall equal the shank diameter of the screw for hardwoods and 90 % of the shank diameter for softwoods. The lead hole in the prism shall have a diameter of 90 % of the root diameter for hardwoods and 70 % of the root diameter for softwoods and shall be $1\frac{5}{8}$ in. (41 mm) deep. The top of the lead hole in the cleat shall be countersunk and the top of the screw inserted flush with the surface.

17. Conditioning

17.1 The material shall be conditioned in accordance with Section 9.

18. Procedure

18.1 As quickly as possible after assembly, but in all cases within 1 h, test each specimen by tensile loading in a testing machine of suitable capacity. Fig. 2 and Fig. 3 show a nail specimen ready for test. Use the same procedure for evaluating the lateral resistance of staples and screws. The end fixtures shall be such as to provide freedom of alignment. Since the load applied to the specimen is eccentric, use an alignment support such as the roller bearing shown. Fig. 2 and Fig. 3 illustrate one method of measuring the differential movement between the two members under load by means of a dial gage. Other methods may be used, including automatic recording. Measure the movement to the nearest 0.001 in. (0.025 mm). Obtain simultaneous values of differential movement and load at movements of 0.01, 0.015, 0.05, 0.1, 0.2, and 0.3 in. (0.25, 0.38, 1.27, 2.54, 5.08, and 7.62 mm), and at maximum load. Record the first drop in load.

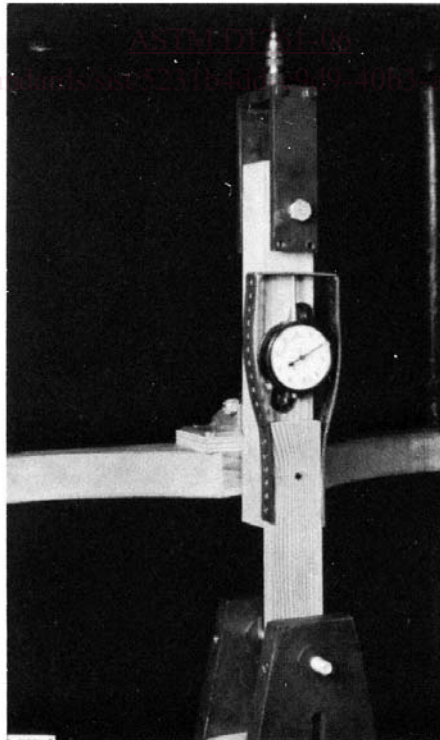

FIG. 2 Assembly for Lateral Resistance Test of Nails, Staples, or Screws