**Textile floor coverings — Determination
of electrical resistance**

Revêtements de sol textiles — Détermination de la résistance électrique

iTeh STANDARD PREVIEW
(standards.iteh.ai)

[ISO 10965:2011](https://standards.iteh.ai/catalog/standards/sist/6642f514-2940-424e-ba5b-a23586f6e45b/iso-10965-2011)

<https://standards.iteh.ai/catalog/standards/sist/6642f514-2940-424e-ba5b-a23586f6e45b/iso-10965-2011>



iTeh STANDARD PREVIEW
(standards.iteh.ai)

[ISO 10965:2011](https://standards.iteh.ai/catalog/standards/sist/6642f514-2940-424e-ba5b-a23586f6e45b/iso-10965-2011)

<https://standards.iteh.ai/catalog/standards/sist/6642f514-2940-424e-ba5b-a23586f6e45b/iso-10965-2011>



COPYRIGHT PROTECTED DOCUMENT

© ISO 2011

All rights reserved. Unless otherwise specified, no part of this publication may be reproduced or utilized in any form or by any means, electronic or mechanical, including photocopying and microfilm, without permission in writing from either ISO at the address below or ISO's member body in the country of the requester.

ISO copyright office
Case postale 56 • CH-1211 Geneva 20
Tel. + 41 22 749 01 11
Fax + 41 22 749 09 47
E-mail copyright@iso.org
Web www.iso.org

Published in Switzerland

Foreword

ISO (the International Organization for Standardization) is a worldwide federation of national standards bodies (ISO member bodies). The work of preparing International Standards is normally carried out through ISO technical committees. Each member body interested in a subject for which a technical committee has been established has the right to be represented on that committee. International organizations, governmental and non-governmental, in liaison with ISO, also take part in the work. ISO collaborates closely with the International Electrotechnical Commission (IEC) on all matters of electrotechnical standardization.

International Standards are drafted in accordance with the rules given in the ISO/IEC Directives, Part 2.

The main task of technical committees is to prepare International Standards. Draft International Standards adopted by the technical committees are circulated to the member bodies for voting. Publication as an International Standard requires approval by at least 75 % of the member bodies casting a vote.

Attention is drawn to the possibility that some of the elements of this document may be the subject of patent rights. ISO shall not be held responsible for identifying any or all such patent rights.

ISO 10965 was prepared by Technical Committee ISO/TC 219, *Floor coverings*.

This second edition cancels and replaces the first edition (ISO 10965:1998). It also incorporates the Technical Corrigendum ISO 10965:1998/Cor.1:1999, which has been technically revised.

INTERNATIONAL STANDARD PREVIEW
(standards.iteh.ai)

ISO 10965:2011
<https://standards.iteh.ai/catalog/standards/sist/6642f514-2940-424e-ba5b-a23586f6e45b/iso-10965-2011>

iTeh STANDARD PREVIEW
(standards.iteh.ai)

ISO 10965:2011

<https://standards.iteh.ai/catalog/standards/sist/6642f514-2940-424e-ba5b-a23586f6e45b/iso-10965-2011>

Textile floor coverings — Determination of electrical resistance

1 Scope

This International Standard describes a laboratory method for the determination of the electrical resistance of textile floor coverings. The method includes both horizontal and vertical measurements.

2 Normative references

The following referenced documents are indispensable for the application of this document. For dated references, only the edition cited applies. For undated references, the latest edition of the referenced document (including any amendments) applies.

ISO 1957, *Machine-made textile floor coverings — Selection and cutting of specimens for physical tests*

3 Terms and definitions

For the purposes of this document, the following terms and definitions apply.

3.1

horizontal resistance

surface resistance

electrical resistance measured between two electrodes placed on the surface of a floor covering

3.2

vertical resistance

surface to back

electrical resistance measured between the surface and the back of a floor covering

3.3

resistance to earth

electrical resistance measured between the surface of a floor covering and the earth

3.4

geometric mean

n^{th} root of the product of n numbers

4 Principle

The horizontal and the vertical resistances of a conditioned test specimen are measured using a high-resistance meter and electrodes under a controlled atmosphere. Horizontal resistance measurement is appropriate for evaluating a floor covering's ability to act as a charge sink. Vertical resistance measurement is appropriate for evaluating a floor covering's ability to conduct charge through to a charge sink beneath it.

The resistance to earth measurement is intended for *in-situ* measurements since the results depend on the quality of the electrical earth during the measurement.

5 Apparatus

5.1 Calibrated high-resistance meter, having changeable nominal open circuit voltages of 500 V and 100 V, and a short-circuit current limited to 10 mA capable of reading resistances from $(1 \times 10^3) \Omega$ to $(1 \times 10^9) \Omega$ to an accuracy of $\pm 5 \%$ and over $(1 \times 10^9) \Omega$ to an accuracy of $\pm 10 \%$. The voltage to be applied shall be chosen from Table 1.

NOTE 1 An equivalent system is a separate voltage source of equivalent capability and a calibrated milliamp meter. Resistance (R) is then calculated by dividing voltage by amperage (I):

$$R = UII$$

Table 1 — Circuit voltages

Resistance, R Ω	Voltage, U V
$\leq 10^8$	100
$> 10^8$	500

NOTE 2 The threshold depends on the apparatus.

5.2 Two metal electrodes (preferably stainless steel), with terminals to make connections to the resistance meter. Each electrode shall weigh a total of $(5,0 \pm 0,1)$ kg, and shall have a flat circular contact area of (65 ± 2) mm in diameter.

NOTE 1 A large (non-conductive) disc may be added as a support platform for the additional weights (see Figure 1).

NOTE 2 To improve the electrical conductivity between the electrode and the sample, the underside of the electrode may be covered with a conductive rubber material, provided that the electrical resistance of this material is at least 100 times more conductive than the lower border of the measuring range.

Dimensions in mm

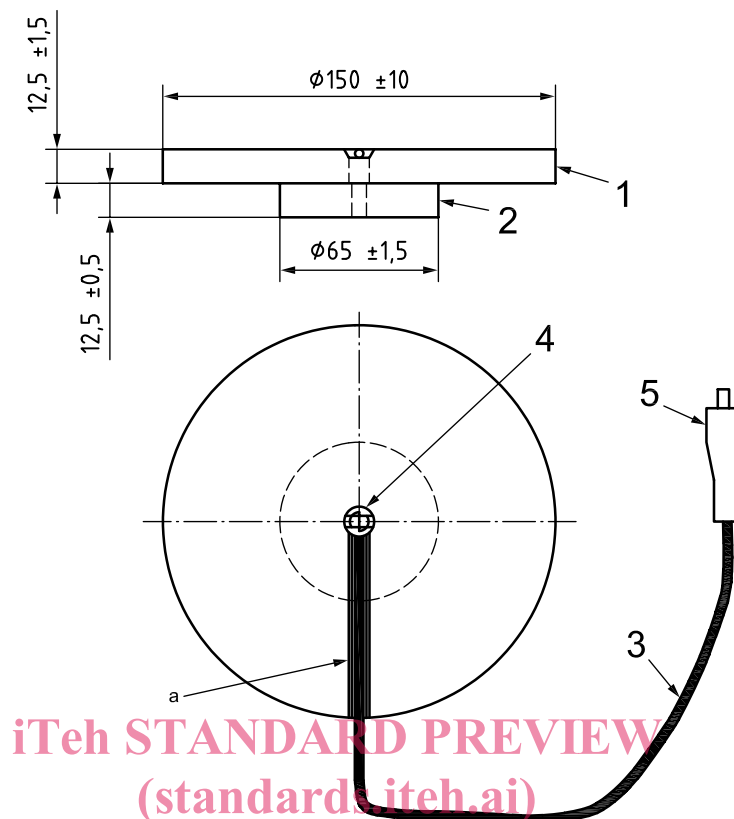
**Key**

- 1 non-conductive weight support disc
- 2 metal electrode
- 3 low-resistance flexible wire
- 4 flat-head screw
- 5 electrical connector

^a Apply epoxy adhesive to bottom of groove to hold wire (3) in place. Strip the wire over 20 mm and wrap around flat head.

Figure 1 — Assembled electrode

5.3 Non-conductive plate (e.g. made of PMMA or PTFE), of dimensions $(600 \pm 10) \text{ mm} \times (600 \pm 10) \text{ mm}$ with a vertical resistance of minimum $(1 \times 10^{13}) \Omega$ measured in accordance with 7.2.

5.4 Earthed metal plate, of dimensions $(600 \pm 1) \text{ mm} \times (600 \pm 1) \text{ mm}$, with an electrical terminal at one side.

6 Sampling and conditioning

6.1 Sampling

Sampling and selection shall be in accordance with ISO 1957. From each sample cut three test specimens measuring $(500 \pm 50) \text{ mm} \times (500 \pm 50) \text{ mm}$.

If the resistance to earth is to be determined, cut a sample measuring $(6,0 \pm 0,1)$ m² or record the size of the room in the case of an installed carpet.

6.2 Conditioning

Pre-condition the test specimen for at least 24 h in an atmosphere of (23 ± 2) °C and (50 ± 5) % relative humidity.

For test climate D, condition for at least 7 days at (23 ± 2) °C and (25 ± 2) % relative humidity.

For test climate N, condition for at least 7 days at (23 ± 2) °C and (50 ± 5) % relative humidity.

In certain areas other atmospheric conditions may be used if agreed between the interested parties. When specimens are tested under these conditions, the atmospheric conditions shall be recorded in the test report.

7 Procedure

7.1 Test A: Horizontal resistance

Carry out the following procedure on each specimen.

Place the insulating plate (5.3) on the earthed metal plate (5.4). Make sure that any charges are eliminated.

Place the test specimen with its face uppermost on the insulating plate. Place the electrodes (5.2) diagonally on the test specimen (500 ± 10) mm distance centre to centre. Connect the electrodes (5.2) to the resistance meter (5.1). Select the test voltage using the values given in Table 1. Take the readings when the resistance value is constant or at latest 1 min after applying the potential to the electrodes (5.2). Take a second reading on the other diagonal. Record the six readings and compute the geometric mean of the results to two significant figures.

<https://standards.iteh.ai/catalog/standards/sist/6642f514-2940-424e-ba5b-a23586f6e45b/iso-10965-2011>

For certain applications it may be necessary to determine the minimum path of electrical resistance across or through the floor covering for evaluation against requirements for electrical safety. In such cases measurements should be made in rectilinear directions, i.e. measurements with the electrodes placed in line parallel to the direction of manufacture and separate measurements with the electrodes in line orthogonal to the direction of manufacture.

7.2 Test B: Vertical resistance

Carry out the following procedure on each specimen.

Place the earthed metal plate (5.4) on the insulating plate (5.3). Make sure that any charges are eliminated.

Put the specimen with its face uppermost on the metal plate. Place one electrode (5.2) no closer than 100 mm from the edge of the test specimen. Connect the electrode (5.2) and the metal plate to the resistance meter (5.1).

Make two measurements at two different places on each specimen with at least 200 mm between them and take the readings when the resistance value is constant or at latest 1 min after applying the potential to the electrodes (5.2). Record the six readings and compute the geometric mean of the results to two significant figures.

7.3 Test C: Resistance to electrical earth

Carry out the following procedure on each specimen.

Place the electrode on the test specimen. Connect the electrode (5.2) to the high resistance meter (5.1) which is connected to earth on the opposite side of the resistance meter. Make measurements at six different places on the specimen with at least 200 mm between them and take the readings when the resistance value is constant or at latest 1 min after applying the potential to the electrodes (5.2). Record the six readings and compute the geometric mean of the results to two significant figures.

To reduce differences between *in-situ* measurements of the resistance to earth and laboratory measurements of the resistance to earth, the laboratory specimen shall measure at least 6 m² and shall be installed on an earthed section of floor (e.g. metal plate). The electrode shall be placed not closer than 100 mm from the edges of the specimen.

8 Test report

The test report shall include the following information:

- a) reference to this International Standard, i.e. ISO 10965;
- b) all the information necessary for complete identification of the sample;
- c) the number of test specimens per sample;
- d) the exact conditioning and testing atmosphere;
- e) applied voltage, individual readings and geometric mean according to the test method A, B or C;
- f) any operations not specified in this International Standard or in the International Standards to which reference is made, or regarded as optional, which might have affected the results;
- g) date of report.