



Designation: D 1525 – 06

Standard Test Method for Vicat Softening Temperature of Plastics¹

This standard is issued under the fixed designation D 1525; the number immediately following the designation indicates the year of original adoption or, in the case of revision, the year of last revision. A number in parentheses indicates the year of last reapproval. A superscript epsilon (ϵ) indicates an editorial change since the last revision or reapproval.

This standard has been approved for use by agencies of the Department of Defense.

1. Scope*

1.1 This test method covers determination of the temperature at which a specified needle penetration occurs when specimens are subjected to specified controlled test conditions.

1.2 This test method is not recommended for ethyl cellulose, nonrigid poly(vinyl chloride), poly(vinylidene chloride), or other materials having a wide Vicat softening range.

1.3 The values stated in SI units are to be regarded as standard.

1.4 *This standard does not purport to address all of the safety concerns, if any, associated with its use. It is the responsibility of the user of this standard to establish appropriate safety and health practices and determine the applicability of regulatory limitations prior to use.*

NOTE 1—This test method and ISO 306:1987(E) are technically equivalent, with the exception of the allowance for creep, prior to beginning the test, in this test method.

2. Referenced Documents

2.1 ASTM Standards:²

- D 618 Practice for Conditioning Plastics for Testing
- D 883 Terminology Relating to Plastics
- D 1898 Practice for Sampling of Plastics³
- E 1 Specification for ASTM Liquid-in-Glass Thermometers
- E 77 Test Method for Inspection and Verification of Thermometers
- E 220 Test Method for Calibration of Thermocouples By Comparison Techniques
- E 644 Test Methods for Testing Industrial Resistance Thermometers
- E 691 Practice for Conducting an Interlaboratory Study to Determine the Precision of a Test Method
- E 1137/E 1137M Specification for Industrial Platinum Resistance Thermometers

sistance Thermometers

2.2 ISO Standards:⁴

- ISO 306 Plastics—Thermoplastic Material—Determination of Vicat Softening Temperature

3. Terminology

3.1 *Definitions*—Definitions of plastics used in this test method are in accordance with those defined in Terminology D 883, unless otherwise specified.

3.1.1 *Vicat softening temperature*—the temperature at which a flat-ended needle of 1-mm² circular cross section will penetrate a thermoplastic specimen to a depth of 1 mm under a specified load using a selected uniform rate of temperature rise.

4. Summary of Test Method

4.1 A flat-ended needle loaded with a specified mass is placed in direct contact with a test specimen. The mass applied can be one of two accepted loads, as follows:

Loading 1— 10 ± 0.2 N

Loading 2— 50 ± 1.0 N

The specimen and needle are heated at either of two permissible rates, as follows:

Rate A— $50 \pm 5^\circ\text{C/h}$

Rate B— $120 \pm 10^\circ\text{C/h}$

The temperature at which the needle has penetrated to a depth of 1 ± 0.01 mm is recorded as the Vicat softening temperature.

5. Significance and Use

5.1 Data obtained by this test method may be used to compare the heat-softening qualities of thermoplastic materials.

5.2 This test method is useful in the areas of quality control, development, and characterization of plastic materials.

6. Apparatus

6.1 The equipment shall be constructed essentially as shown in Fig. 1 and shall consist of the following:

¹ This test method is under the jurisdiction of ASTM Committee D20 on Plastics and is the direct responsibility of Subcommittee D20.30 on Thermal Properties (Section D20.30.07).

Current edition approved March 15, 2006. Published April 2006. Originally approved in 1958. Last previous edition approved in 2000 as D 1525 - 00.

² For referenced ASTM standards, visit the ASTM website, www.astm.org, or contact ASTM Customer Service at service@astm.org. For *Annual Book of ASTM Standards* volume information, refer to the standard's Document Summary page on the ASTM website.

³ Withdrawn.

⁴ Available from American National Standards Institute (ANSI), 25 W. 43rd St., 4th Floor, New York, NY 10036.

*A Summary of Changes section appears at the end of this standard.

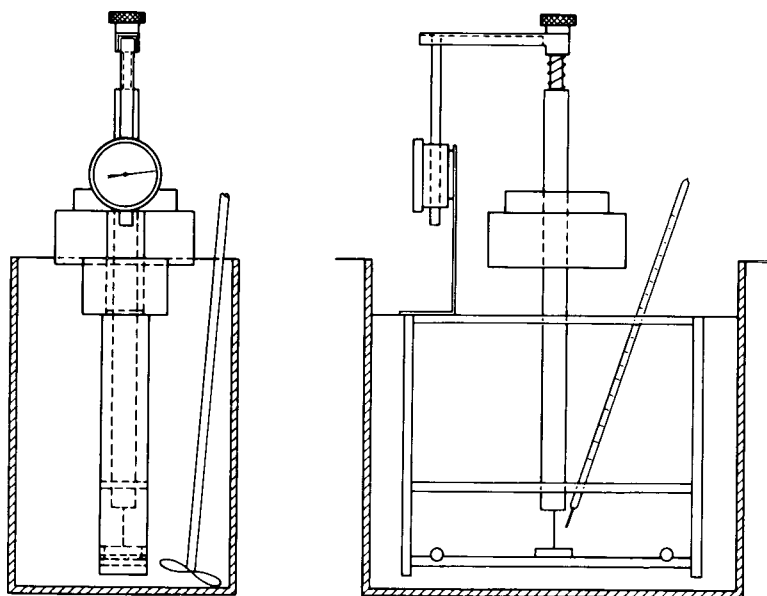

FIG. 1 Apparatus for Softening Temperature Determination

6.1.1 *Immersion Bath*—The bath containing the heat-transfer medium shall be equipped with a stirrer, temperature-measuring device, and heater. The heater shall have automatic control of the selected bath temperature-rise rate (see 4.1). The bath should be constructed to allow the specimens to be submerged at least 35 mm below the surface of the heat-transfer medium.

6.1.2 *Heat-Transfer Medium*—Several liquids, such as silicone oils, glycerine, ethylene glycol, and mineral oil have been used successfully for various plastics.⁵ The medium used shall be free from contaminants and shall have no short-time effect at elevated temperatures on the material being tested, and shall be of low viscosity at room temperature. The results of the test may depend on the thermal diffusivity of the heat-transfer medium.

NOTE 2—It is desirable to have a method of cooling the bath in order to reduce the time required to lower the temperature of the bath between tests. This may be accomplished by using a cooling coil installed in the bath or an external heat-transfer system. If the temperature rise rate is adversely affected by the presence of residual coolant in the cooling coils, the coolant should be purged prior to beginning the test.

6.1.3 *Specimen Support*—A suitable stand or support for the specimen to be placed in the bath. The vertical members that attach the specimen support to the upper plate shall be made of a material having the same coefficient of expansion as that used for the rod through which the load is applied in order that the penetration-measuring device reading caused by differential expansion over the intended temperature range does not exceed 0.02 mm when the specimen is replaced by a piece of heat-resistant material.⁶

6.1.4 *Penetration-Measuring Device*—The device used for measuring the penetration of the specimen shall be capable of

measuring a penetration depth of at least 1 ± 0.01 mm. The measuring device may be an analog or digital dial gauge or similar device, including an electronic-displacement sensing apparatus.

6.1.5 *Masses*—A set of masses of suitable sizes shall be supplied so that the net force on the needle point shall be equal to 10 ± 0.2 N (Loading 1) or 50 ± 1.0 N (Loading 2) when the apparatus is assembled. The net force shall consist of the weight of the needle assembly, the force attributed to action of the penetration-measuring device, and the extra weight that is required to balance the system. The required mass is calculated as follows:

$$\text{Required mass, } m_w = (F - F_s)/9.80665 - m_r$$

- F = total force to be applied to the specimen, N,
- F_s = force exerted by any penetration-measuring device, N (this is a positive value if the thrust of the spring is towards the specimen (downward), a negative value if the thrust of the spring is opposing the descent of the rod, or zero if no such device is involved),
- m_r = mass of the needle rod assembly, kg, and
- m_w = extra mass applied to attain the desired force, kg.

Verification of the load should be made on new equipment and after replacing penetration-measuring devices, or at any time to ensure that the equipment is in calibration. The calibration procedure for dial-gauge-type penetration-measuring devices is described in Appendix X1 and Appendix X2. The methods for determination of the thrust contributed by dial-gauge-type penetration-measuring devices are also given in Appendix X1 and Appendix X2.

6.1.6 *Temperature-Measuring Device*—A thermocouple, resistance thermometer (RTD), or thermometer adequate to cover the range being tested. The thermometer shall be one of the following, or its equivalent, in accordance with Specification E 1: Thermometer 1C or 2C, having ranges from -20 to 150°C

⁵ Silicone oils having a room temperature viscosity of 100 cP have been found satisfactory and safe for short-term heat cycles up to 260°C .

⁶ Borosilicate glass has been found satisfactory for this purpose.

or -5 to 300°C , respectively, depending on the test range. The thermocouple or resistance thermometer and related electronics shall be accurate to at least $\pm 0.5^{\circ}\text{C}$. Mercury-in-glass thermometers shall be calibrated for the depth of immersion in accordance with Test Method E 77. Thermocouples shall be calibrated in accordance with Test Method E 220. Resistance thermometers shall comply with the requirements of Test Methods E 644 and Specification E 1137/E 1137M.

6.1.7 *Needle*—A flat-tipped, hardened steel needle with a cross-sectional area of $1.000 \pm 0.015 \text{ mm}^2$ (diameter of 1.120 to 1.137 mm) shall be used. The tip shall be free of burrs and be perpendicular to the axis of the rod. The needle shall protrude at least 2 mm from the end of the rod.

7. Sampling

7.1 Unless otherwise agreed upon between the seller and the purchaser, sample in accordance with the sections on General Sampling Procedures and Specific Sampling Procedures of Practice D 1898. Sampling based on engineering principles, prior to packaging, shall be considered an acceptable alternative.

8. Test Specimen

8.1 Use at least two specimens to test each sample. The specimen shall be flat, between 3 and 6.5 mm thick, and at least 10 by 10 mm in area or 10 mm in diameter. When necessary to use multiple layers, no more than three layers of material may be stacked in order to achieve the minimum thickness. The specimens may be cut from sheet or molded material. The type of mold and the molding process used to produce test specimens will affect the results obtained in the test. Molding conditions shall be in accordance with the standard for the material being tested or should be agreed upon between the cooperating laboratories.

NOTE 3—Discrepancies in test results due to variations in molding conditions may be minimized by annealing the test specimens before the test. Since different materials require different annealing conditions, annealing procedures shall be employed only if required by the material standard or if agreed upon between the cooperating laboratories.

9. Conditioning

9.1 If conditioning of the specimens is required, the test specimens shall be conditioned at $23 \pm 2^{\circ}\text{C}$ and at $50 \pm 5\%$ relative humidity for not less than 40 h in accordance with Practice D 618.

NOTE 4—Conditioning periods less than the 40 h, as specified by Practice D 618, may be used when it is shown that the Vicat softening temperature is not affected by the shorter conditioning time. Longer conditioning times may be required for some materials that take longer to reach temperature and humidity equilibrium. Refer to the applicable ASTM standards for those materials.

10. Procedure

10.1 Prepare the immersion bath so that the temperature of the heat-transfer medium is between 20 and 23°C at the start of the test unless previous tests have shown that for a particular material under test no error is introduced by starting at a higher temperature. The bath should be well stirred.

NOTE 5—Under certain conditions, it may be difficult to bring the

temperature of the heat-transfer medium down to 20 to 23°C . In these cases, the test may be started with the bath temperature at 30°C . The selection of the starting temperature shall be agreed upon between the cooperating laboratories.

10.2 Place the specimen, which is at room temperature, on the specimen support so that it is approximately centered under the needle. The needle should not be nearer than 3 mm to the edge of the specimen. Gently lower the needle rod, without the extra mass, so that the needle rests on the surface of the specimen and holds it in position.

10.3 Position the temperature measuring device so that the sensing end is located within 10 mm from where the load is applied to the surface of the specimen. The sensing end should not touch the specimen.

10.4 Lower the assembly into the bath, taking care not to jar it in any way that would damage or dislodge the specimen.

10.5 Apply the extra mass required to increase the load on the specimen to $10 \pm 0.2 \text{ N}$ (Loading 1) or $50 \pm 1.0 \text{ N}$ (Loading 2). After a 5-min waiting period, set the penetration indicator to zero.

10.6 Start the temperature rise. The rate of temperature increase shall be either $50 \pm 5^{\circ}\text{C/h}$ (Rate A) or $120 \pm 10^{\circ}\text{C/h}$ (Rate B) and shall be uniform throughout the test. The Rate A heating requirement shall be considered to be met if over every 12-min interval during the test, the temperature of the bath rises $10 \pm 1^{\circ}\text{C}$ at each specimen location. The Rate B heating requirement shall be considered to be met if over every 6-min interval during the test, the temperature of the bath rises $12 \pm 1^{\circ}\text{C}$ at each specimen location. The selection of the rate of rise shall be agreed upon between cooperating laboratories. See Annex A1 for calibration of single temperature probe units.

10.7 Record the temperature of the bath when the needle has penetrated $1 \pm 0.01 \text{ mm}$ into the test specimen. Take care to ensure that an accurate reading of the temperature is made since the rate of penetration of the specimen will be increasing rapidly at this point.

10.8 Express the Vicat softening temperature as the arithmetic mean of the temperature of penetration of all specimens tested. If the range of penetration temperatures for the individual test specimens exceeds 2°C , record the individual results and repeat the test, using at least two new specimens.

NOTE 6—If a permanent record is desired, either read and record the penetration for each 5°C rise in temperature until the penetration reaches 0.4 mm, and at 2°C intervals thereafter, or attach a displacement transducer, having the same resolution as the gauge, to each rod and continuously record the rate of penetration by means of a multichannel recorder or similar data-acquisition device.

NOTE 7—Some commercially available instruments record the time at which the penetration reaches a set depth. If this type of instrument is used, make a time-temperature calibration before the specimens are tested. This calibration compensates for slight variations in the heating rate. (Warning—Even though the variations may be within the specifications set forth in 10.6, the compounded error over the range of the test can produce a substantial error in the Vicat softening temperature.)

11. Report

11.1 Report the following information:

11.1.1 Reference to this test method,

11.1.2 Complete identification of the material tested,

TABLE 1 Vicat Softening Temperature Using Loading 1 and Rate B, Values Expressed in Units of °C

Material	Average	S_r^A	S_R^B	r^C	R^D	Number of Participating Laboratories
Ethylene vinyl acetate	72.4	1.44	2.29	4.03	6.40	10
Polystyrene	97.3	0.68	2.36	1.91	6.62	10
High-density polyethylene	127.9	1.04	2.73	2.90	7.63	10
Polypropylene	152.5	1.13	2.83	3.16	7.91	10
Nylon 66	251.2	0.70	5.06	1.96	14.16	7

^A S_r = within-laboratory standard deviation of the average.

^B S_R = between-laboratories standard deviation of the average.

^C r = within-laboratory repeatability limit = 2.8 S_r .

^D R = between-laboratories reproducibility limit + 2.8 S_R .

TABLE 2 Vicat Softening Temperature Using Loading 2 and Rate A, Values Expressed in Units of °C

Material	Average	S_r^A	S_R^B	r^C	R^D
Polypropylene (PP0343)	56.2	1.07	1.86	2.99	5.22
Polypropylene (PP0114)	92.5	1.47	4.08	4.12	11.44
Impact Modified Acrylic (PMMA0230V1)	94.1	0.32	1.96	0.91	5.48
ABS	94.4	0.62	1.61	1.74	4.52
High Heat ABS (ABS0135)	100.8	0.34	1.53	0.95	4.29
Unmodified Acrylic (PMMA0141V3)	105.1	1.44	1.48	1.23	4.15
Polycarbonate (PC0136)	143.6	0.19	1.24	0.53	3.48
Polycarbonate (PC0123)	143.8	0.38	1.03	1.05	2.89

^A S_r = within-laboratory standard deviation for the indicated material. It is obtained by pooling the within-laboratory standard deviations of the test results from all of the participating laboratories:

$$S_r = [((S_1)^2 \dots + (S_n)^2)/n]^{1/2}$$

^B S_R = between-laboratories reproducibility, expressed as standard deviation: $S_R = [S_r^2 + S_L^2]^{1/2}$ where S_L = standard deviation of laboratory means.

^C r = within-laboratory critical interval between two test results = 2.8 \times S_r .

^D R = between-laboratories critical interval between two test results = 2.8 \times S_R .

11.1.3 Method of preparing test specimens, including conditioning and annealing methods used,

11.1.4 Initial starting temperature,

11.1.5 Rate of temperature rise, Rate A (50°C/h) or Rate B (120°C/h),

11.1.6 Total load applied to the specimen, Loading 1 (10 ± 0.2 N) or Loading 2 (50 ± 1.0 N),

11.1.7 Thickness of the specimen and the number of layers of the material that were used,

11.1.8 Heat-transfer medium,

11.1.9 Vicat softening temperature, expressed as the arithmetic mean of the Vicat softening temperatures of the individual specimens, and

11.1.10 Any observations relating to the test.

12. Precision and Bias⁷

12.1 *Precision*—Tables 1 and 2 have been developed in accordance with Practice E 691. Table 1, for the case using Loading 1 (10 ± 0.2 N) and Heating Rate B (120 ± 10°C/h) is based on round-robin tests conducted in 1982 involving five materials and differing numbers of laboratories as noted in the table. Each laboratory obtained three test results for each material. Table 2, for the case using Loading 2 (50.0 ± 1.0 N) and Heating Rate A (50 ± 5°C/h) is based on round-robin tests conducted in 1994 involving 8 materials and six laboratories. Each laboratory obtained two test results for each material. In both cases, for each material, all of the individual specimens

from all material samples were prepared by one source. Each test result was the average of two individual determinations.

(Warning—The following explanations of r and R (see 12.1.1-12.1.1.3) are intended only to present a meaningful way of considering the approximate precision of this test method. The data given in Tables 1 and 2 should not be applied rigorously to the acceptance or rejection of material, as those data are specific to the round-robin test and may not be representative of other lots, conditions, materials, or laboratories. Users of this test method should apply the principles outlined in Practice E 691 to generate data specific to their laboratory and materials, or between specific laboratories. The principles of 12.1.1-12.1.1.3 would then be valid for such data.)

12.1.1 *Concept of r and R* —If S_r and S_R have been calculated from a large enough body of data, and for test results that were averages from testing two specimens, the following applies:

12.1.1.1 *Repeatability, r* —In comparing two test results for the same material obtained by the same operator using the same equipment on the same day, the two test results obtained within one laboratory shall be judged as not equivalent if they differ by more than the “ r ” value for that material. “ r ” is the interval representing the critical difference between two test results for the same material, obtained by the same operator using the same equipment on the same day in the same laboratory.

12.1.1.2 *Reproducibility, R* —In comparing two test results for the same material obtained by different operators using different equipment in different laboratories on different days, the two test results obtained by different laboratories shall be

⁷ Supporting data are available from ASTM Headquarters. Request RR:D20:1194.