International Standard



562

INTERNATIONAL ORGANIZATION FOR STANDARDIZATION • МЕЖДУНАРОДНАЯ ОРГАНИЗАЦИЯ ПО СТАНДАРТИЗАЦИИ • ORGANISATION INTERNATIONALE DE NORMALISATION

Hard coal and coke — Determination of volatile matter content

Houille et coke — Détermination du taux de matières volatiles

Second edition — 1981-11-01

iTeh STANDARD PREVIEW
(standards.iteh.ai)

[ISO 562:1981](https://standards.iteh.ai/catalog/standards/sist/6ce06c86-c1a9-4ca8-b363-ca40e4b36a46/iso-562-1981)

<https://standards.iteh.ai/catalog/standards/sist/6ce06c86-c1a9-4ca8-b363-ca40e4b36a46/iso-562-1981>

UDC 662.66 : 662.749.2 : 543.813

Ref. No. ISO 562-1981 (E)

Descriptors : coal, coke, chemical analysis, determination of content, volatility, volatile matter, measurement, tests, physical tests.

Foreword

ISO (the International Organization for Standardization) is a worldwide federation of national standards institutes (ISO member bodies). The work of developing International Standards is carried out through ISO technical committees. Every member body interested in a subject for which a technical committee has been set up has the right to be represented on that committee. International organizations, governmental and non-governmental, in liaison with ISO, also take part in the work.

Draft International Standards adopted by the technical committees are circulated to the member bodies for approval before their acceptance as International Standards by the ISO Council.

International Standard ISO 562 was developed by Technical Committee ISO/TC 27, *Solid mineral fuels*.

This second edition was submitted directly to the ISO Council, in accordance with clause 5.10.1 of part 1 of the Directives for the technical work of ISO. It cancels and replaces the first edition (i.e. ISO 562-1974), which had been approved by the member bodies of the following countries:

Australia	Iran	Sweden
Austria	Italy	Switzerland
Belgium	Japan	Turkey
Brazil	Philippines	United Kingdom
Chile	Poland	USA
Czechoslovakia	Portugal	USSR
Germany, F.R.	Romania	Yugoslavia
Greece	South Africa, Rep. of	
India	Spain	

The member bodies of the following countries had expressed disapproval of the document on technical grounds:

France
Netherlands

Hard coal and coke — Determination of volatile matter content

0 Introduction

The volatile matter content is determined as the loss in mass less that due to moisture, when coal or coke is heated out of contact with air under standardized conditions. The test is empirical and, in order to ensure reproducible results, it is essential that the rate of heating, the final temperature and the overall duration of the test shall be carefully controlled. The moisture content of the sample shall be determined at the same time as the volatile matter content so that the appropriate correction can be made.

Mineral matter associated with the sample may also lose mass under the conditions of test, the magnitude of the loss being dependent on both the nature and the quantity of the minerals present. When the carbonate content of a coal is high or when the result is required for the purpose of classifying the coal, it is necessary to make a correction to the determined volatile matter content for the loss of carbon dioxide occurring during the determination. A first approximation to this correction is obtained by the use of equation (3).

NOTE — Insufficient experimental evidence is available to justify a correction for loss of carbon dioxide being recommended when determining the volatile matter content of coke. On the other hand, the error from this source is unlikely to be great, as carbonates are decomposed in the coke oven in making coke, although some carbonates may be added subsequently if the coke is quenched with waste liquor.

The apparatus and procedure are so specified that one or more determinations may be carried out simultaneously in the muffle furnace.

1 Scope and field of application

This International Standard specifies a method of determining the volatile matter content of hard coal and of coke. It is not applicable to brown coals and lignites.

2 References

- ISO 331, *Coal — Determination of moisture in the analysis sample — Direct gravimetric method.*
- ISO 348, *Hard coal — Determination of moisture in the analysis sample — Direct volumetric method.*
- ISO 687, *Coke — Determination of moisture in the analysis sample.*
- ISO 925, *Solid mineral fuels — Determination of carbon dioxide content — Gravimetric method.*
- ISO 1170, *Coal and coke — Calculation of analyses to different bases.*
- ISO 1171, *Solid mineral fuels — Determination of ash.*

3 Principle

The sample is heated at 900 °C out of contact with air for 7 min. The percentage of volatile matter is calculated from the loss in mass of the sample after deducting the loss in mass due to moisture.

4 Reagents

4.1 Desiccant, fresh or freshly regenerated and preferably self-indicating. Suitable desiccants are silica gel, activated alumina and anhydrous calcium sulphate.

4.2 Benzene (for use with coke samples).

5 Apparatus

5.1 Muffle furnace, heated by electricity, in which an adequate zone at a constant and uniform temperature of 900 ± 10 °C can be maintained. It may be of the stop-ended type or fitted at the back with a flue approximately 25 mm diameter and 150 mm long.

Its heat capacity shall be such that, with an initial temperature of 900 °C, a minimum temperature of 885 °C is regained within 4 min, preferably within 3 min, of the insertion of a cold stand and its crucible(s), the temperature being measured with an unsheathed thermocouple, as described in 5.2. Normally the furnace¹⁾ will be designed specifically either for receiving one crucible and its stand or for multiple determinations using a number of crucibles in one stand.

NOTE — The temperature of 900 °C shall be attained as closely as possible and the tolerance of ± 10 °C is specified so as to meet inherent errors in the temperature measurement and lack of uniformity in the temperature distribution.

A position for the crucible stand shall be chosen within the zone of uniform temperature and this position used for all determinations.

5.2 Pyrometer.

The temperature characteristics of the furnace shall be checked with an unsheathed thermocouple, of wire not thicker than 1 mm. The thermojunction shall be inserted midway between the base of the crucible in its stand and the floor of the furnace. If the stand holds more than one crucible, then the temperature under each crucible shall be checked in the same manner. If desired, a sheathed thermocouple may be permanently installed in the furnace with its thermojunction as close as possible to the centre of the zone of uniform temperature; in this case, its temperature readings shall be correlated at frequent intervals with those of the unsheathed thermocouple, which is then inserted only when necessary.

NOTE — The temperature/electromotive force relationship of a thermojunction maintained at elevated temperatures gradually changes with time.

5.3 Crucible and lid: A cylindrical crucible with a well-fitting lid, both of fused silica. The crucible and lid shall have a mass between 10 and 14 g and dimensions approximating to those shown in figure 1. The fit of the lid on the crucible is critical to the determination and a lid shall be selected to match the crucible so that the horizontal clearance between them is not greater than 0,5 mm. After selection, the crucible and the lid shall be ground together to give smooth surfaces and then be given a common distinguishing mark.

NOTE — When carrying out multiple determinations on highly swelling coals, it may be necessary to use taller crucibles; these may be up to

45 mm in height without affecting the determined volatile matter content, provided that the specified rate of temperature recovery is maintained.

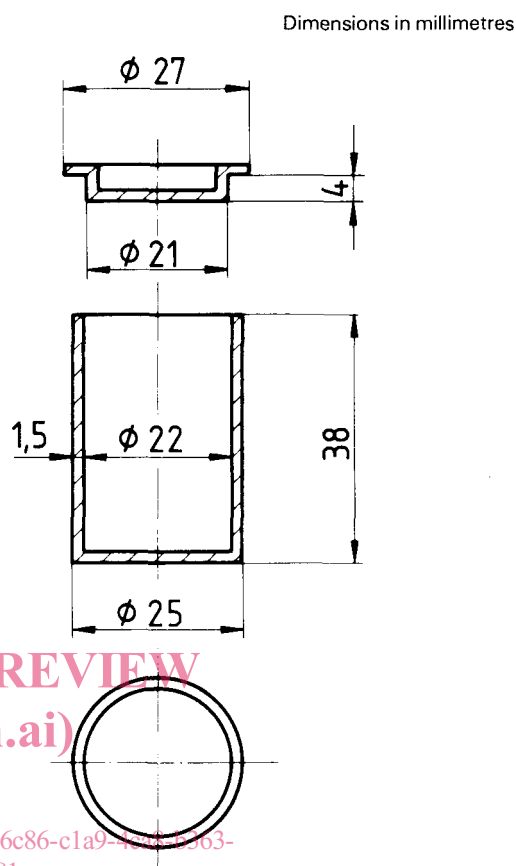

Figure 1 — Silica crucible and lid

Crucibles of other refractory materials or of platinum may be used if they give the same results as the recommended silica crucible, within the stated tolerances.

5.4 Stand, on which the crucible is placed in the muffle furnace, such that the appropriate rate of heating can be achieved. For example, it may consist of the following:

- a) for single determinations: a ring of heat-resistant steel wire as shown in figure 2 a), with two asbestos disks, 25 mm diameter and 1 mm thick, resting on the inner projection of its legs; or
- b) for multiple determinations: a tray of heat-resistant steel wire as shown in figure 2 b), of appropriate size, with an asbestos plate 2 mm thick supporting the crucibles.

5.5 Balance, accurate to 0,1 mg.

1) A suitable furnace for use with one crucible is specified in the British standard BS 1016: Part 3, and a suitable furnace for use with several crucibles is specified in the German standard DIN 51720.

Dimensions in millimetres

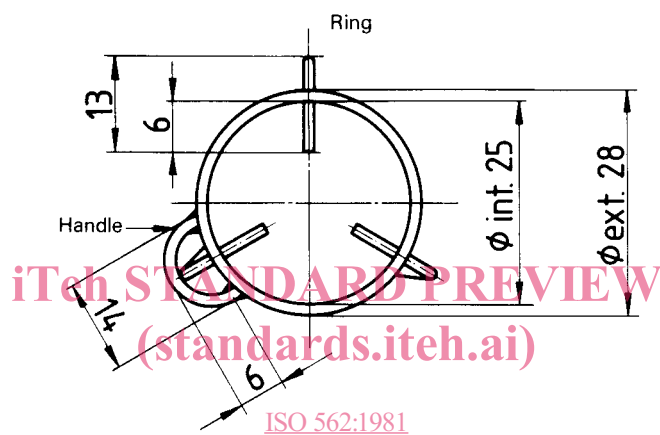
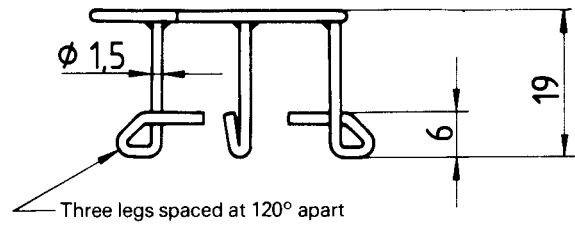

<https://standards.iteh.ai/catalog/standards/sist/6ce06c86-c1a9-4ca8-b363-ca40c4b30a40/iso-562-1981>

a) Suitable for a single determination

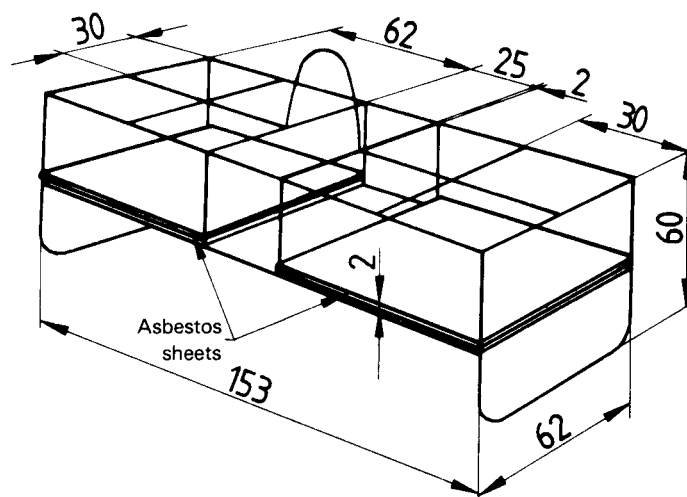

b) Suitable for multiple determinations

Figure 2 — Crucible stands

6 Preparation of sample

The sample used for the determination of volatile matter content is the analysis sample ground to pass a sieve of 200 μm aperture.

If necessary, expose the sample in a thin layer for the minimum time required for the moisture content to reach approximate equilibrium with the laboratory atmosphere.

Before commencing the determination, mix the air-dried sample of coal or coke for at least 1 min, preferably by mechanical means.

7 Procedure

Heat in the muffle furnace (5.1) at 900 ± 10 °C for 7 min either one crucible and lid (5.3) or the requisite number of crucibles and lids to fill the multiple stand (5.4). Remove from the furnace, allow the crucible(s) to cool first on a metal slab and finally in a desiccator located next to the balance. As soon as these are cool, weigh each empty crucible and lid and weigh into each crucible, to the nearest 0,1 mg, 1,00 to 1,01 g of sample. Replace the lid and tap the crucible on a clean, hard surface until the sample forms a layer of even thickness on the bottom of the crucible.

NOTE — Precisely similar treatment of the crucible before and after the determination minimizes the effect of any film of water absorbed on its surface, while the rapid cooling reduces absorption of moisture by the coal or coke residue.

Adjust the temperature of the zone in the muffle furnace, containing a stand and empty crucible(s), to 900 ± 10 °C as indicated by the correctly located unsheathed thermocouple (5.2), or to the equivalent temperature as indicated by the sheathed thermocouple. Remove the stand and empty crucible(s) and close the door of the muffle furnace to restore steady temperature conditions.

If the sample is of coke, remove the lid of the charged crucible, add 2 to 4 drops of the benzene (4.2) and replace the lid. Place the charged crucible(s) in another stand, transfer to the muffle furnace, close the door and leave for exactly 7 min. Remove, cool and weigh the crucible(s) in the same manner as for the empty crucible(s).

NOTE — If multiple determinations are being made, any vacant places in the stand should be filled with empty crucibles.

8 Expression of results

The volatile matter on a dry, ash-free basis (V_{daf})¹⁾, expressed as a percentage by mass, is given by the equations

$$V = \frac{100(m_2 - m_3)}{m_2 - m_1} - M \quad \dots (1)$$

$$V_{daf} = \frac{V \times 100}{100 - (M + A)} \quad \dots (2)$$

$$V_{daf} \text{ (corrected for CO}_2\text{)} = (V - \text{CO}_2) \times \frac{100}{100 - (M + A)} \quad \dots (3)$$

where

m_1 is the mass, in grams, of the empty crucible and lid;

m_2 is the mass, in grams, of the crucible and lid and sample before heating;

m_3 is the mass, in grams, of the crucible and lid and contents after heating;

M is the moisture, as a percentage by mass, in the sample as analysed, determined according to the method specified in ISO 331, ISO 348 or ISO 687;

A is the ash, as a percentage by mass, of the sample as analysed, determined according to the method specified in ISO 1171;

CO_2 is the carbon dioxide content, as a percentage by mass, in the sample as analysed, determined according to the method specified in ISO 925;

V is the volatile matter, as a percentage by mass, in the sample as analysed.

The results (preferably the mean of duplicate determinations, see clause 9) shall be expressed to the nearest 0,1 %.

9 Precision of the method

Sample	Maximum acceptable differences between results obtained (calculated to the same moisture content)	
	In the same laboratory (Repeatability)	In different laboratories (Reproducibility)
Hard coal of volatile matter content < 10 %	0,3 % absolute	0,5 % absolute
Hard coal of volatile matter content > 10 %	3 % of the mean result	0,5 % absolute or 4 % of the mean result, whichever is the greater
Coke	0,2 % absolute	(see 9.3)

9.1 Repeatability

The results of duplicate determinations, carried out at different times in the same laboratory by the same operator using the

1) Calculation of the results to other bases is dealt with in ISO 1170.

same apparatus on two representative portions taken from the same analysis sample, shall not differ by more than the above values.

9.2 Reproducibility (hard coal)

The means of the results of duplicate determinations, carried out in each of two different laboratories on representative portions taken from the same sample after the final stage of sample preparation, shall not differ by more than the above values.

9.3 Reproducibility (coke)

No value for reproducibility can be quoted for determinations on coke carried out in different laboratories, as insufficient evidence is available for this to be done.

10 Test report

The test report shall include the following particulars:

- a) an identification of the product tested;
- b) the reference of the method used;
- c) the results and the method of expression used;
- d) any unusual features noted during the determination;
- e) any operation not included in this International Standard, or regarded as optional.

iTeh STANDARD PREVIEW (standards.iteh.ai)

ISO 562:1981

<https://standards.iteh.ai/catalog/standards/sist/6ce06c86-c1a9-4ca8-b363-ca40e4b36a46/iso-562-1981>

iTeh STANDARD PREVIEW
(standards.iteh.ai)

ISO 562:1981

<https://standards.iteh.ai/catalog/standards/sist/6ce06c86-c1a9-4ca8-b363-ca40e4b36a46/iso-562-1981>