



SLOVENSKI STANDARD

SIST EN 957-8:2002

01-september-2002

BYdfYa] bUcdfYa UnUj UXVc '!', "XY. 'GHdYf1žhY_c Y'glc db]Wžj ndYb'U b_]"]
8 cXUtbY dcgYVbYj UfbcgfbY nU hYj Y]b'dfYg_i gbY'a YrcXY

Stationary training equipment - Part 8: Steppers, stairclimbers and climbers - Additional specific safety requirements and test methods

Stationäre Trainingsgeräte - Teil 8: Stepper, Treppensteiggeräte und Climber - Zusätzliche besondere sicherheitstechnische Anforderungen und Prüfverfahren

iTeh STANDARD PREVIEW

Appareils d'entraînement fixes - (Partie 8: Monte-escaliers, escalators et simulateurs d'escalade - Prescriptions spécifiques de sécurité et méthodes d'essai supplémentaires)

[SIST EN 957-8:2002](https://standards.iteh.ai/catalog/standards/sist/d724ad43-6c5b-46fb-a129-35471ac6438c/sist-en-957-8-2002)

Ta slovenski standard je istoveten z: [EN 957-8:1998](https://standards.iteh.ai/catalog/standards/sist/d724ad43-6c5b-46fb-a129-35471ac6438c/sist-en-957-8-2002)

ICS:

97.220.30

SIST EN 957-8:2002

en

iTeh STANDARD PREVIEW
(standards.iteh.ai)

SIST EN 957-8:2002

<https://standards.iteh.ai/catalog/standards/sist/d724ad43-6c5b-46fb-a129-53471ae6438e/sist-en-957-8-2002>

ICS 97.220.30

Descriptors: sport equipment, gymnastic equipment, fixed equipment, escalators, mountaineering, simulation, specifications, safety, tests, technical notices

English version

Stationary training equipment - Part 8: Steppers, stairclimbers and climbers - Additional specific safety requirements and test methods

Appareils d'entraînement fixes - Partie 8: Monte-escaliers, escalators et simulateurs d'escalade - Prescriptions spécifiques de sécurité et méthodes d'essai supplémentaires

Stationäre Trainingsgeräte - Teil 8: Stepper, Treppensteigergeräte und Climber - Zusätzliche besondere sicherheitstechnische Anforderungen und Prüfverfahren

This European Standard was approved by CEN on 6 June 1998.

CEN members are bound to comply with the CEN/CENELEC Internal Regulations which stipulate the conditions for giving this European Standard the status of a national standard without any alteration. Up-to-date lists and bibliographical references concerning such national standards may be obtained on application to the Central Secretariat or to any CEN member.

This European Standard exists in three official versions (English, French, German). A version in any other language made by translation under the responsibility of a CEN member into its own language and notified to the Central Secretariat has the same status as the official versions.

CEN members are the national standards bodies of Austria, Belgium, Czech Republic, Denmark, Finland, France, Germany, Greece, Iceland, Ireland, Italy, Luxembourg, Netherlands, Norway, Portugal, Spain, Sweden, Switzerland and United Kingdom.

iTeh STANDARD PREVIEW
(standards.iteh.ai)

SIST EN 957-8:2002

<https://standards.iteh.ai/catalog/standards/sist/d724ad42-5c5b-46fb-a129-53471ae6438e/sist-en-957-8-2002>



EUROPEAN COMMITTEE FOR STANDARDIZATION
COMITÉ EUROPÉEN DE NORMALISATION
EUROPÄISCHES KOMITEE FÜR NORMUNG

Central Secretariat: rue de Stassart, 36 B-1050 Brussels

Contents

	Page
Foreword	
Introduction	2
1 Scope	3
2 Normative references	3
3 Definitions	3
4 Classification	6
5 Safety requirements	6
6 Test methods	9
7 Additional instructions for use	11

Foreword

This European Standard has been prepared by Technical Committee CEN/TC 136 "Sports, playground and other recreational equipment", the secretariat of which is held by DIN.

This European Standard shall be given the status of a national standard, either by publication of an identical text or by endorsement, at the latest by December 1998, and conflicting national standards shall be withdrawn at the latest by December 1998.

This standard EN 957 "Stationary training equipment" consists of the following parts:

Part 1: General safety requirements and test methods

Part 2: Strength training equipment, additional specific safety requirements and test methods

Part 4: Strength training benches, additional specific safety requirements and test methods

Part 5: Pedal crank training equipment, additional specific safety requirements and test methods

Part 6: Treadmills, additional specific safety requirements and test methods

Part 7: Rowing machines, additional specific safety requirements and test methods

Part 8: Steppers, stairclimbers and climbers, additional specific safety requirements and test methods

According to the CEN/CENELEC Internal Regulations, the national standards organizations of the following countries are bound to implement this European Standard: Austria, Belgium, Czech Republic, Denmark, Finland, France, Germany, Greece, Iceland, Ireland, Italy, Luxembourg, Netherlands, Norway, Portugal, Spain, Sweden, Switzerland and the United Kingdom.

ITEH STANDARD PREVIEW
(standards.iteh.ai)

Introduction

[SIST EN 957-8:2002](https://standards.iteh.ai/catalog/standards/sist/d724ad43-6c5b-46fb-a129-53471ae6438e/sist-en-957-8-2002)

[https://standards.iteh.ai/catalog/standards/sist/d724ad43-6c5b-46fb-a129-](https://standards.iteh.ai/catalog/standards/sist/d724ad43-6c5b-46fb-a129-53471ae6438e/sist-en-957-8-2002)

This part of EN 957 concerns the safety of **steppers, stairclimbers and climbers**.

It amends and supplements EN 957-1. The requirements of this specific standard take priority over those in the general standard.

1 Scope

This part of EN 957 specifies safety requirements for stepper, stairclimber and climber machines (hereafter called training equipment) in addition to the general safety requirements of EN 957-1 and should be read in conjunction with it.

This part of EN 957 is applicable to stationary training equipment type stepper, stairclimber and climber training equipment (type 8), within classes S and H and class A for accuracy.

2 Normative references

This European Standard incorporates, by dated or undated reference, provisions from other publications. These normative references are cited at the appropriate places in the text and the publications are listed hereafter. For dated references, subsequent amendments to or revisions of any of these publications apply to this European Standard only when incorporated in it by amendment or revision. For undated references, the latest edition of the publication referred to applies.

EN 71-1

Safety of toys – Part 1: Mechanical and physical properties

EN 957-1 : 1996

Stationary training equipment – Part 1: General safety requirements and test methods

ISO 5904

Gymnastic equipment – Landing mats and surfaces for floor exercises – Determination of resistance to slipping

3 Definitions

For the purposes of this standard the definitions of EN 957-1 and the following apply.

3.1 stepper: Stationary training equipment where the feet move in a reciprocating motion without the foot having to leave the foot pedal (see figure 1).

3.2 stairclimber: Stationary training equipment similar to a moving mechanical staircase or escalator (see figure 2).

NOTE: Work is carried out by simulating climbing a conventional staircase.

3.3 Climber: Stationary training equipment that is equipped with feet and hand positions that can be moved in a reciprocating motion (see figure 3).

3.4 dependent action: Movement of each foot pedal linked directly or indirectly,
<https://standards.iteh.ai/catalog/standards/sist/d724ad43-6c5b-461b-a129-53471ae6438e/sist-en-957-8-2002>

3.5 independent action: Movement of each foot pedal not linked.

3.6 step: Downward movement of either foot pedal or stair.

3.7 foot guard: A raised edge, see figures 1 and 5.

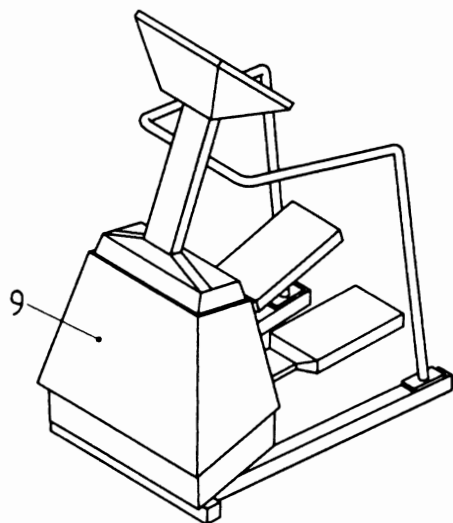

a) Stepper class S

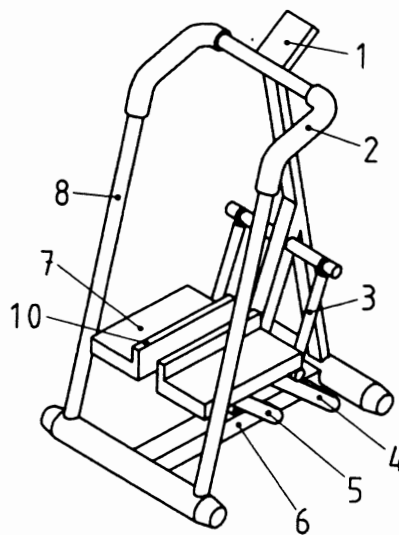

b) Stepper class H

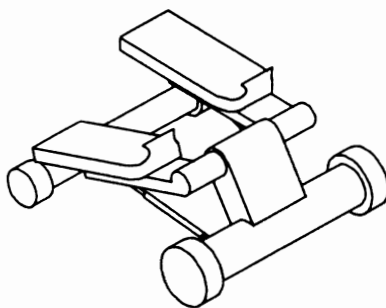

c) Ministepper

- 1 Display
- 2 Hand grip
- 3 Hydraulic piston/resistance
- 4 Lever arm
- 5 Pedal stabilizing arm
- 6 Base frame
- 7 Foot pedal
- 8 Handrail/handlebar
- 9 Housing
- 10 Foot guard

iTeh STANDARD PREVIEW
(standards.iteh.ai)

Figure 1: Examples of steppers

SIST EN 957-8:2002

<https://standards.iteh.ai/catalog/standards/sist/d724ad43-6c5b-46fb-a129-53471ae6438e/sist-en-957-8-2002>

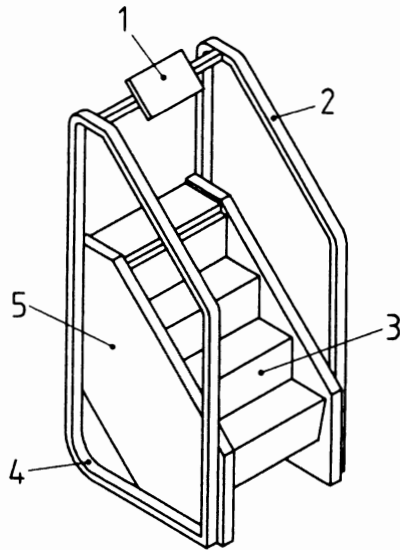

- 1 Display
- 2 Handrail
- 3 Stair
- 4 Base frame
- 5 Housing

Figure 2: Example of a stairclimber

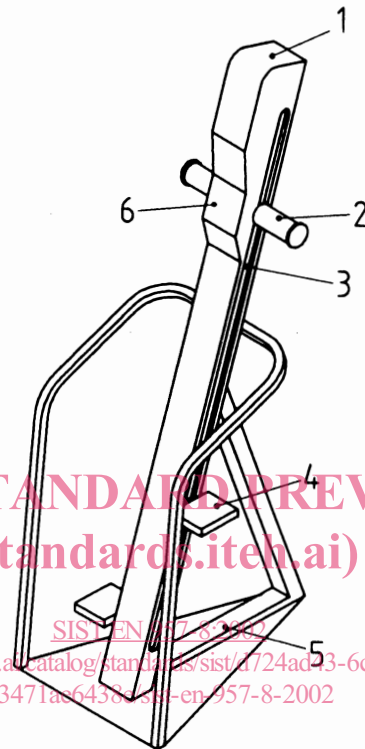

iTeh STANDARD PREVIEW
(standards.iteh.ai)

SIST EN 957-8:2002
<https://standards.iteh.ai/catalog/standards/sist/a724ad23-6c5b-46fb-a129-53471ac6458c/sist-en-957-8-2002>

- 1 Display
- 2 Movable handgrip
- 3 Track rail
- 4 Foot pedal
- 5 Base frame
- 6 Resistance adjustment

Figure 3: Example of a climber

4 Classification

Clause 4 of EN 957-1 : 1996 applies.

5 Safety requirements

5.1 General

Depending on the design of the piece of equipment the requirements in accordance with 5.2 to 5.8 shall apply as appropriate.

5.2 External construction

5.2.1 Squeeze, shear and reciprocating parts within the accessible area

The distance between movable parts and adjacent movable or rigid parts shall be at least 25 mm if relevant only for fingers, otherwise it shall be 60 mm.

Required stops are excluded (if the user is not put at risk).

The 25 mm and 60 mm do not apply when the squeeze points remain within the user's field of vision (see figure 4) over the full range of movement.

When the training machine is not in use the 25 mm requirement applies.

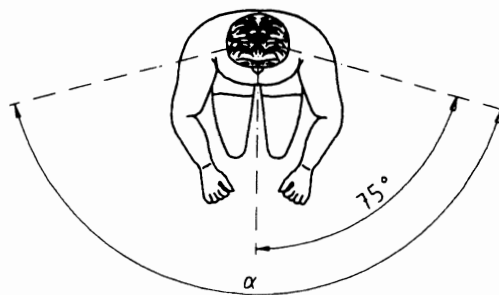

Figure 4: Field of vision

If the distance between the pedals is more than 60 mm no fence is required on the inside of the foot pedals (see figure 5 a)).

Where the pedals are separated by a fixed part of the machine (e.g. a frame, guard or smooth cover) with a minimum width of 30 mm, there shall be a constant distance of not more than 9,5 mm and no foot guard is required on the inside of the foot pedals (see figure 5 b)).

Where the inside edge of the foot pedals have a foot guard 30 mm high, the distance between the foot pedals can be a minimum of 25 mm (see figure 5 c)).

In all 3 cases there shall be no further projections within the free space, e.g. bolts, beyond the inside edge of the pedals.

Dimensions in millimeters

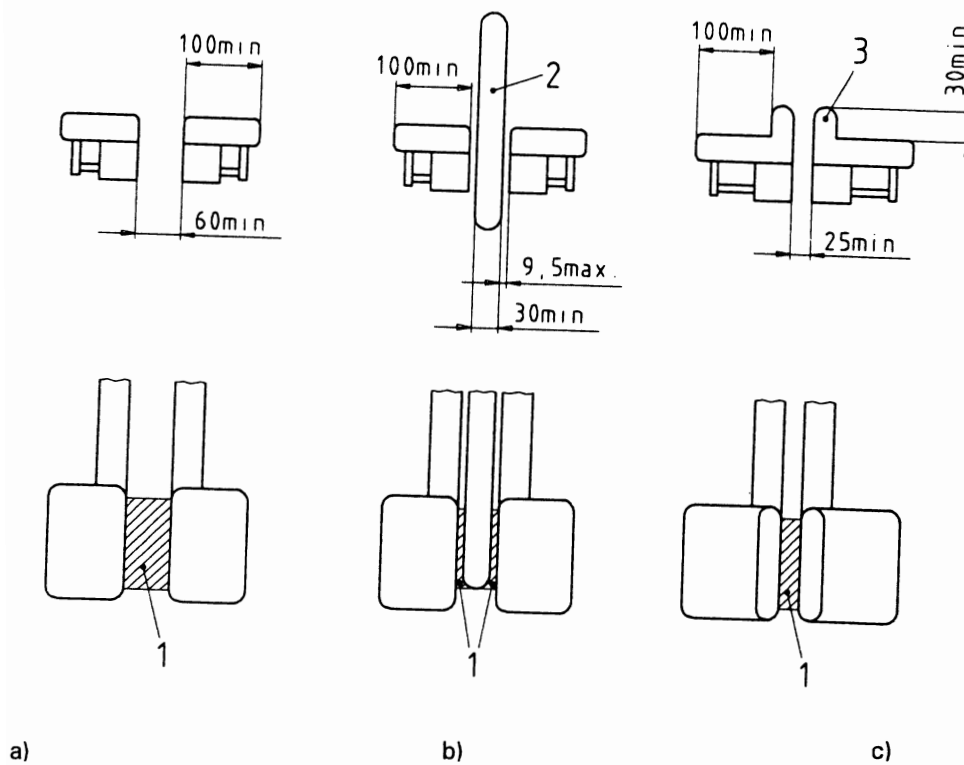

- 1 free space
- 2 closed flat area with constant distance
- 3 foot guard

Figure 5: Squeeze points

If the lever arm or foot pedal is used as an accessible stop this stop shall have a flat contact area with a minimum surface area of 800 mm² and edges of the stop shall have a minimum radius of 2,5 mm. The maximum stop load shall not exceed the body weight.

The minimum distance between the base of the foot pedal and the floor or base frame shall be not less than 60 mm, excluding accessible stops.

Test in accordance with 6.2.

ITeH STANDARD PREVIEW
(standards.iteh.ai)

5.2.2 Transmission elements and rotating parts

All transmission elements, e.g. fans and flywheels, shall be protected, so that users finger cannot be trapped.

Test in accordance with 6.2.

5.2.3 Temperature rise

Immediately after testing in accordance with 6.3, accessible parts of the equipment shall not exceed a temperature greater than 65 °C.