

---

# International Standard



# 601

---

INTERNATIONAL ORGANIZATION FOR STANDARDIZATION • МЕЖДУНАРОДНАЯ ОРГАНИЗАЦИЯ ПО СТАНДАРТИЗАЦИИ • ORGANISATION INTERNATIONALE DE NORMALISATION

---

## Solid mineral fuels — Determination of arsenic content using the standard silver diethyldithiocarbamate photometric method of ISO 2590

*Combustibles minéraux solides — Détermination de la teneur en arsenic utilisant la méthode photométrique au diéthylthiocarbamate d'argent normalisée dans l'ISO 2590*

ITC STANDARD PREVIEW

First edition — 1981-12-15

(standards.iteh.ai)

[ISO 601:1981](https://standards.iteh.ai/catalog/standards/sist/c13fe653-dfc8-49c0-8759-f8ff710bb540/iso-601-1981)

<https://standards.iteh.ai/catalog/standards/sist/c13fe653-dfc8-49c0-8759-f8ff710bb540/iso-601-1981>

---

UDC 662.62 : 543.42 : 546.19

Ref. No. ISO 601-1981 (E)

Descriptors : solid fuels, coal, tests, determination of content, arsenic, silver diethyldithiocarbamate, spectrophotometric analysis.

## Foreword

ISO (the International Organization for Standardization) is a worldwide federation of national standards institutes (ISO member bodies). The work of developing International Standards is carried out through ISO technical committees. Every member body interested in a subject for which a technical committee has been set up has the right to be represented on that committee. International organizations, governmental and non-governmental, in liaison with ISO, also take part in the work.

Draft International Standards adopted by the technical committees are circulated to the member bodies for approval before their acceptance as International Standards by the ISO Council.

International Standard ISO 601 was developed by Technical Committee ISO/TC 27, *Solid mineral fuels*, and was circulated to the member bodies in November 1979.

It has been approved by the member bodies of the following countries :

Australia	Germany, F. R.	South Africa, Rep. of
Austria	India	United Kingdom
Belgium	Korea, Rep. of	USA
Bulgaria	Netherlands	USSR
Canada	Poland	Yugoslavia
Denmark	Romania	

The member body of the following country expressed disapproval of the document on technical grounds :

Czechoslovakia

This International Standard cancels and replaces ISO Recommendation R 601-1967, of which it constitutes a technical revision.

# Solid mineral fuels — Determination of arsenic content using the standard silver diethyldithiocarbamate photometric method of ISO 2590

## 1 Scope and field of application

This International Standard specifies a method for the photometric determination of amounts of arsenic in hard coal, brown coal and lignite and coke using the silver diethyldithiocarbamate method in accordance with ISO 2590.

The method is applicable to the determination of arsenic (As) contained either in all the test solution or in the aliquot portion taken for the determination of between 1 and 20 µg corresponding to not less than 1 ppm in the test portion.

## 2 References

ISO 383, *Laboratory glassware — Interchangeable conical ground joints*.

ISO 2590, *General method for the determination of arsenic*.  
*Silver diethyldithiocarbamate photometric method*.

## 3 Principle

Oxidation of the sample by nitric and sulphuric acids or by the use of Eschka mixture. Then, using the method specified in ISO 2590, reduction of the arsenic by zinc in sulphuric acid or hydrochloric acid medium with the formation of arsine and absorption of the arsine in a solution of silver diethyldithiocarbamate in pyridine, followed by photometric measurement of the purplish-red colour produced by the colloiddally dispersed silver at the maximum of the absorption curve (wavelength approximately 540 nm).

NOTE — The reaction of the formation of the colloidal silver is :

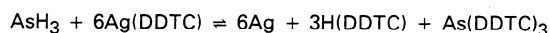

## 4 Reagents

During the analysis, use only reagents of recognized analytical grade, and only distilled water or water of equivalent quality. All the reagents and the zinc in particular shall be free from arsenic or have a very low arsenic content. In addition to the reagents specified in ISO 2590, clause 4, the following are required.

**4.1 Sulphuric acid**, concentrated, ρ 1,84 g/ml, (for 7.2).

**4.2 Nitric acid**, concentrated, ρ 1,42 g/ml, (for 7.2).

**4.3 Hydrochloric acid**, ρ 1,18 g/ml, (for 7.1).

**4.4 Eschka mixture** (for 7.1).

Mix two parts by mass of light calcined magnesium oxide with one part of anhydrous sodium (or potassium) carbonate. The mixture shall entirely pass a test sieve of 212 µm nominal aperture.

## 5 Apparatus

All glass apparatus shall be constructed from borosilicate glass. Ground glass joints, when used, shall comply with the requirements specified in ISO 383. The balance used shall be accurate to 0,1 mg.

In addition to the apparatus specified in ISO 2590, clause 5, the following is required :

**5.1 Digestion apparatus** (see the figure) (for 7.2), consisting of the following :

**5.1.1 Kjeldahl flask**, of capacity 300 ml, fitted with a 24/29 ground glass socket complying with the requirements of ISO 383.

**5.1.2 Fume ducts**, of outside diameter approximately 28 mm, fitted with a dropping funnel of capacity at least 15 ml and a 24/29 ground glass cone, complying with the requirements of ISO 383. The fume ducts may be of one piece or assembled from separate units by means of ground glass joints.

**5.1.3 Fume extractor**, consisting of a glass tube, of diameter approximately 40 mm, sealed at one end and drawn out at the other end to form a connection to the water pump. The tube is fitted with a drain stopcock and a series of lipped holes to accommodate a number of fume ducts.

**5.1.4 Glass water pump**.

**5.1.5 Digestion rack**, fitted with several positions, each of which will accommodate a Kjeldahl flask held at an angle of 45°, with a holder for the fume extractor.

**5.2 Muffle furnace** (for 7.1), electrically heated, with a zone of substantially uniform temperature at 800 ± 25 °C. The ventilation through the muffle furnace shall be such as to give about five air changes per minute.

NOTE — The number of air changes per minute can be assessed by the measurement of the air flow in the muffle furnace flue by means of a pitot-static tube and sensitive manometer.

**5.3 Crucibles** (for 7.1), of porcelain or silica, of capacity approximately 25 ml.

**5.4 Insulating plate** (for 7.1), of silica, 6 mm thick, or its equivalent of such size as to be an easy sliding fit into the muffle furnace (5.2).

## 6 Sample preparation

The sample of coal or coke shall be the analysis sample (air dried) ground to pass a sieve of 212  $\mu\text{m}$  aperture. The sample shall be thoroughly mixed for at least 1 min, preferably by mechanical means, immediately before the determination.

## 7 Procedure

### 7.1 Dry oxidation method

**7.1.1** Weigh, to the nearest 0,1 mg, a test portion of about 1 g of the sample in a scoop.

**7.1.2** Transfer the test portion (7.1.1) to a crucible (5.3) containing about 2 g of the Eschka mixture (4.4). Mix thoroughly using a small spatula and cover with a further 1 g of the Eschka mixture (4.4).

**7.1.3** Place the crucible on the insulating plate (5.4), insert the plate and crucible into the cool muffle furnace (5.2), and heat the furnace to a temperature of 800 °C. Maintain this temperature for 5 h. Withdraw the crucible and allow it to cool.

**7.1.4** Transfer the incinerated mixture quantitatively to a flask. Wash the crucible with 10 ml of hot water and transfer the wash water to the flask. Add 20 ml of the hydrochloric acid (4.3) to dissolve the mixture.

**7.1.5** Transfer quantitatively to the conical flask (see ISO 2590, sub-clause 5.1.1) the total solution or a suitable aliquot portion such that it contains between 1 and 20  $\mu\text{g}$  of arsenic and dilute to 40 ml.

NOTE — If an aliquot portion is taken, sufficient hydrochloric acid should be added to ensure that the HCl concentration is approximately 3 mol/l.

### 7.2 Wet oxidation method

**7.2.1** Weigh, to the nearest 0,1 mg, a test portion of about 1 g of sample.

**7.2.2** Transfer the test portion (7.2.1) to a clean dry Kjeldahl flask (5.1.1), tapping the neck of the flask. Assemble the apparatus (5.1) as shown in the figure, in a well-ventilated fume cupboard. Add 7 ml of the sulphuric acid (4.1) and 3,5 ml of

the nitric acid (4.2) by means of the dropping funnel, rotating the flask so as to wash down any sample remaining in the neck.

**7.2.3** After the initial reaction has subsided, heat the flask carefully so that the reaction proceeds smoothly and without frothing. Continue heating the flask under the same conditions until only fumes of sulphuric acid are evolved. Add 0,2 to 0,4 ml of the nitric acid (4.2) to the dropping funnel and run the acid, drop by drop, into the flask.

NOTE — If violent frothing occurs on addition of the mixed acid, apply a damp cloth to the neck of the flask, and heat intermittently as the frothing subsides.

**7.2.4** Heat for 2 to 3 min until no more dense brown fumes are evolved. Repeat the addition of the nitric acid and the heating, rotating the flask periodically to wash down any carbonaceous matter adhering to the sides of the flask, until all visible carbonaceous matter has been oxidized and the solution is a pale greenish-yellow colour. This may take 1 1/2 to 2 h, or even longer in exceptional cases with some coke samples.

NOTE — For the first 15 min of heating a coal sample, the reaction mixture is a tarry mass; subsequently it changes its colour from black to dark reddish-brown, to amber, and finally to pale greenish-yellow.

If after 45 min heating, a black liquid still remains, then either

- too low a temperature has been used and the nitric acid has not reacted with the sample; raise the temperature to distil off excess nitric acid, then continue the normal oxidation as described above, or
- too high a temperature has been used, nitric acid being distilled off without reacting; cool, add further nitric acid and heat the mixture as described above.

**7.2.5** Heat the flask more strongly until white fumes appear and allow to fume for 5 min. Cool the flask to approximately room temperature, remove the dropping funnel and fume duct assembly and add a few glass beads to the contents of the flask.

NOTE — If the colour reverts to amber or deep red, add a further 0,2 to 0,4 ml of the nitric acid, heat to fuming and allow to fume for 5 min.

**7.2.6** Add cautiously 10 ml of water, heat until white fumes appear and then allow to fume gently for 10 min. Cool the flask until the evolution of the white fumes ceases, add 0,2 ml of the nitric acid, reheat the flask and allow to fume for a further 10 min.

**7.2.7** To ensure complete oxidation, cool the flask to approximately room temperature and repeat the procedure specified in 7.2.6.

**7.2.8** Cool the flask to approximately room temperature, add 10 ml of water, heat to fuming and allow to fume for 20 min. Add a further 10 ml of water, heat to fuming, allow to fume for 10 min and cool.

NOTE — It is essential to ensure that all traces of nitric acid are eliminated, otherwise the test will be invalidated.

**7.2.9** Transfer quantitatively to the conical flask (see ISO 2590, sub-clause 5.1.1) the total solution or a suitable aliquot portion such that it contains between 1 and 20 µg of arsenic and dilute to 40 ml.

NOTE — If an aliquot portion is taken, sufficient sulphuric acid should be added to ensure that the H<sub>2</sub>SO<sub>4</sub> concentration is approximately 2 mol/l.

**7.3 Blank test**

See sub-clause 6.2 of ISO 2590.

**7.4 Preparation of the calibration curve**

See sub-clause 6.3 of ISO 2590.

**7.5 Determination**

See sub-clause 6.4 of ISO 2590.

**8 Expression of results**

Calculate the arsenic content (As), as a percentage by mass, from the formula

$$As = \frac{a \times 10^{-4}}{m}$$

where

*a* is the arsenic equivalent, in micrograms, to the photometric measurement of the test solution less the arsenic equivalent of the blank;

*m* is the mass, in grams, of the test portion or the mass of material in the aliquot portion of the test solution.

Calculate the arsenic(III) oxide (As<sub>2</sub>O<sub>3</sub>) content, as a percentage by mass, from the formula

$$As_2O_3 = As \times 1,320\ 4$$

Report the result to the nearest 0,000 1 % (*m/m*).

**9 Precision of the method**

**9.1 Repeatability**

The results of duplicate determinations carried out at different times in the same laboratory by the same operator with the same apparatus on two representative portions taken from the same sample (see clause 6) should not differ by more than the values given in the table below.

**9.2 Reproducibility**

The means of the results of duplicate determinations carried out in two different laboratories on representative portions taken from the same sample (see clause 6) should not differ by more than the values given in the table below.

Arsenic(III) oxide (As <sub>2</sub> O <sub>3</sub> ) content % ( <i>m/m</i> )	Repeatability	Reproducibility
Less than 0,000 6	0,000 1 % absolute	0,000 1 % absolute
Equal to or more than 0,000 6	± 10 % of the mean of the two results	± 10 % of the mean of the two results

iTeh STANDARD PREVIEW (standards.iteh.ai)

ISO 601:1981  
<https://standards.iteh.ai/catalog/standards/sist/c13fe693-49c0-8759-2010-54601-1981>

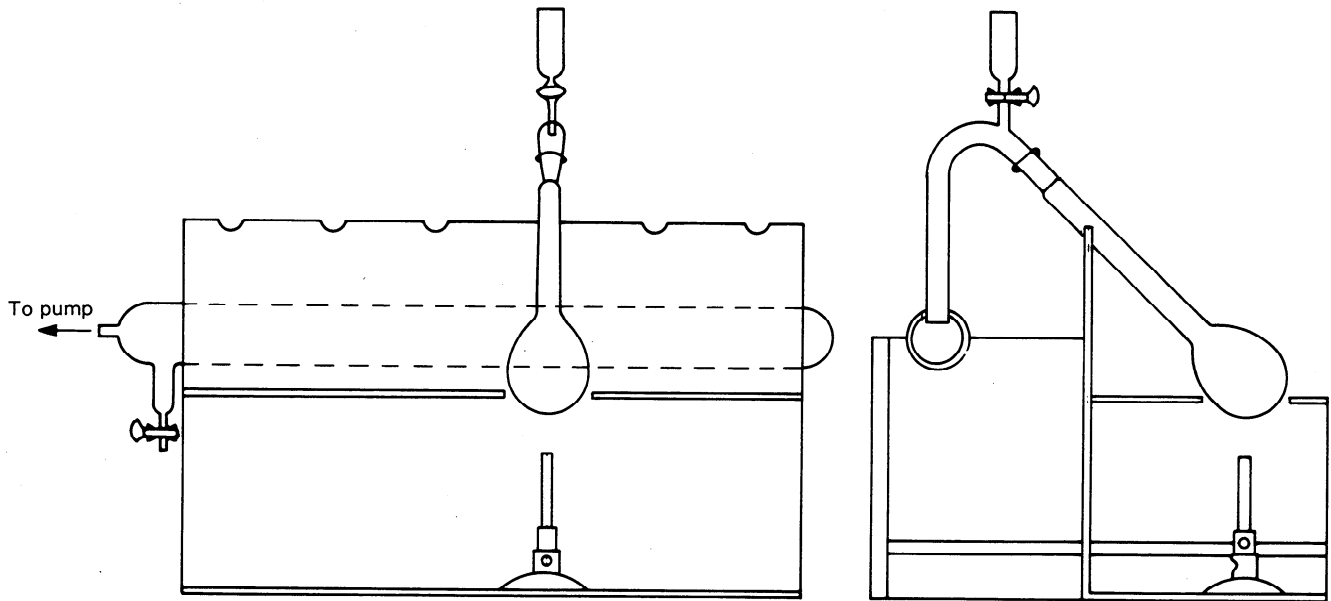

Figure – Apparatus for the wet oxidation of the sample

**iTeh STANDARD PREVIEW**  
**(standards.iteh.ai)**

ISO 601:1981

<https://standards.iteh.ai/catalog/standards/sist/c13fe653-dfc8-49c0-8759-f8ff710bb540/iso-601-1981>

**iTeh STANDARD PREVIEW**  
This page intentionally left blank  
**(standards.iteh.ai)**

ISO 601:1981

<https://standards.iteh.ai/catalog/standards/sist/c13fe653-dfc8-49c0-8759-f8ff710bb540/iso-601-1981>

**iTeh STANDARD PREVIEW**  
This page intentionally left blank  
**(standards.iteh.ai)**

ISO 601:1981

<https://standards.iteh.ai/catalog/standards/sist/c13fe653-dfc8-49c0-8759-f8ff710bb540/iso-601-1981>