



**iTeh STANDARD PREVIEW**  
**(standards.iteh.ai)**

[SIST EN 301 926 V1.3.1:2017](https://standards.iteh.ai/catalog/standards/sist/d765312a-46fd-4d86-bf66-c1b50d57457b/sist-en-301-926-v1-3-1-2017)

<https://standards.iteh.ai/catalog/standards/sist/d765312a-46fd-4d86-bf66-c1b50d57457b/sist-en-301-926-v1-3-1-2017>

# ETSI EN 301 926 V1.3.1 (2017-10)



**Satellite Earth Stations and Systems (SES);  
Radio Frequency and Modulation Standard  
for Telemetry, Command and Ranging (TCR)  
of Communications Satellites**

<https://standards.iteh.ai/catalog/standards/sist/d765312a-46fd-4d86-bf66-c1b50d57457b/sist-en-301-926-v1-3-1-2017>

---

**Reference**REN/SES-00401

---

**Keywords**coding, modulation, satellite, telemetry

---

**ETSI**

---

650 Route des Lucioles  
F-06921 Sophia Antipolis Cedex - FRANCE

---

Tel.: +33 4 92 94 42 00 Fax: +33 4 93 65 47 16

Siret N° 348 623 562 00017 - NAF 742 C  
Association à but non lucratif enregistrée à la  
Sous-Préfecture de Grasse (06) N° 7803/88

iTeh STANDARD PREVIEW  
(standards.iteh.ai)

---

**Important notice**

---

<https://standards.iteh.ai/catalog/standards/sist/d765312a-46fd-4d86-bf66-c1b09b745708/sist-en-301-926-v1-3-1-2017>  
The present document can be downloaded from:  
<http://www.etsi.org/standards-search>

The present document may be made available in electronic versions and/or in print. The content of any electronic and/or print versions of the present document shall not be modified without the prior written authorization of ETSI. In case of any existing or perceived difference in contents between such versions and/or in print, the only prevailing document is the print of the Portable Document Format (PDF) version kept on a specific network drive within ETSI Secretariat.

Users of the present document should be aware that the document may be subject to revision or change of status.

Information on the current status of this and other ETSI documents is available at

<https://portal.etsi.org/TB/ETSIDeliverableStatus.aspx>

If you find errors in the present document, please send your comment to one of the following services:

<https://portal.etsi.org/People/CommiteeSupportStaff.aspx>

---

**Copyright Notification**

---

No part may be reproduced or utilized in any form or by any means, electronic or mechanical, including photocopying and microfilm except as authorized by written permission of ETSI.

The content of the PDF version shall not be modified without the written authorization of ETSI.

The copyright and the foregoing restriction extend to reproduction in all media.

© ETSI 2017.

All rights reserved.

**DECT™**, **PLUGTESTS™**, **UMTS™** and the ETSI logo are trademarks of ETSI registered for the benefit of its Members.

**3GPP™** and **LTE™** are trademarks of ETSI registered for the benefit of its Members and of the 3GPP Organizational Partners.

**oneM2M** logo is protected for the benefit of its Members.

**GSM®** and the GSM logo are trademarks registered and owned by the GSM Association.

# Contents

Intellectual Property Rights .....	5
Foreword.....	5
Modal verbs terminology.....	5
1 Scope .....	6
2 References .....	7
2.1 Normative references .....	7
2.2 Informative references.....	8
3 Definitions and abbreviations.....	8
3.1 Definitions.....	8
3.2 Abbreviations .....	11
4 Modulation Requirements .....	12
4.1 General .....	12
4.2 Frequency and Phase Modulations.....	13
4.2.1 Modulating waveforms .....	13
4.2.2 PCM waveforms and data rates .....	14
4.2.3 Use of subcarriers .....	15
4.2.4 Choice of Subcarrier Frequencies.....	15
4.2.5 Uplink Carrier Frequency Deviation (Frequency Modulation).....	16
4.2.6 Uplink PM Modulation Index.....	16
4.2.7 Downlink PM Modulation Index.....	16
4.2.8 Sense of Modulation .....	16
4.2.9 Data Transition Density .....	16
4.2.10 Modulation Linearity .....	16
4.2.11 Residual Amplitude Modulation.....	17
4.2.12 Residual Carrier, Out-of-band Emission and Discrete Spectral Lines.....	17
4.3 Spread Spectrum Modulation.....	18
4.3.1 General.....	18
4.3.2 Chip Shaping .....	20
4.3.3 Out-of-Band Emission and Discrete Spectral Lines .....	20
4.4 Coherency Properties .....	20
5 Requirements on Transmitted Signals.....	21
5.1 Frequency Stability.....	21
5.1.1 Uplink .....	21
5.1.2 Downlink .....	21
5.2 Turnaround Frequency Ratio.....	21
5.3 Polarization.....	21
5.4 Phase Noise .....	21
5.4.1 Ground Transmitter.....	21
5.4.2 On-board Transmitter .....	22
6 Link Acquisition Requirements.....	22
6.1 Link Acquisition Performance .....	22
6.2 Physical Layer Operations Procedures.....	22
7 Coding and Interleaving .....	23
7.1 Uplink.....	23
7.2 Downlink.....	23
<b>Annex A (informative): Operational Configuration.....</b>	<b>24</b>
A.1 Introduction .....	24
A.2 Configuration Baseline: on board spread spectrum transponder.....	25
A.3 Configuration Alternative 1: on board dual mode receiver and on board dual mode transmitter .....	26
A.4 Configuration Alternative 2: on board dual mode receiver and phase modulation transmitter.....	27

A.5	Configuration Alternative 3: on board dual mode receiver, phase modulation transmitter and dedicated RG SS transmitter .....	29
A.6	Configuration Alternative 4: on board dual mode multi-channel receiver and on board dual mode transmitter (for hosted payload management).....	30
<b>Annex B (informative):</b>	<b>Hybrid Ranging process description.....</b>	<b>32</b>
B.1	Introduction .....	32
B.2	Presentation .....	32
B.3	Distance ambiguity resolution.....	33
<b>Annex C (informative):</b>	<b>Modulator imperfections.....</b>	<b>34</b>
C.1	Phase imbalance .....	34
C.2	BPSK phase imbalance .....	34
C.3	QPSK phase imbalance .....	34
C.4	Amplitude imbalance .....	34
C.5	Data asymmetry.....	35
C.6	Data bit jitter.....	35
C.7	PN code asymmetry.....	35
C.8	PN code chip jitter.....	35
C.9	Chip transition time .....	35
C.10	I/Q data bit skew .....	36
C.11	I/Q PN code chip skew.....	36
<b>Annex D (informative):</b>	<b>SRRC (chip filtering).....</b>	<b>37</b>
<b>Annex E (normative):</b>	<b>PN code assignment, generation and set specification.....</b>	<b>39</b>
E.1	PN codes.....	39
E.2	PN code assignment .....	39
E.3	PN code generation .....	39
E.3.1	PN code generator types.....	39
E.3.1a	Telecommand uplink or in-phase channel (Mode MTC2, MTC3 Acquisition) .....	42
E.3.2	Ranging uplink or quadrature channel (Mode MTC2).....	42
E.3.3	Telecommand and ranging uplink (Mode MTC3 Tracking) .....	43
E.4	Telemetry Downlink.....	43
E.4.1	Coherent ranging mode (Mode MTM2).....	43
E.4.2	Non coherent mode (Mode MTM3).....	43
E.5	Baseline PN code set specification.....	43
E.6	Extended PN code library.....	45
E.7	Code Examples.....	46
E.8	PN CODE REQUEST FORM.....	49
E.8.1	Form .....	49
E.8.2	Description and Instructions.....	49
<b>Annex F (informative):</b>	<b>Performance computations .....</b>	<b>51</b>
<b>Annex G (informative):</b>	<b>Bandwidth considerations and assumptions .....</b>	<b>52</b>
History .....		53

---

## Intellectual Property Rights

### Essential patents

IPRs essential or potentially essential to the present document may have been declared to ETSI. The information pertaining to these essential IPRs, if any, is publicly available for **ETSI members and non-members**, and can be found in ETSI SR 000 314: "*Intellectual Property Rights (IPRs); Essential, or potentially Essential, IPRs notified to ETSI in respect of ETSI standards*", which is available from the ETSI Secretariat. Latest updates are available on the ETSI Web server (<https://ipr.etsi.org/>).

Pursuant to the ETSI IPR Policy, no investigation, including IPR searches, has been carried out by ETSI. No guarantee can be given as to the existence of other IPRs not referenced in ETSI SR 000 314 (or the updates on the ETSI Web server) which are, or may be, or may become, essential to the present document.

### Trademarks

The present document may include trademarks and/or tradenames which are asserted and/or registered by their owners. ETSI claims no ownership of these except for any which are indicated as being the property of ETSI, and conveys no right to use or reproduce any trademark and/or tradename. Mention of those trademarks in the present document does not constitute an endorsement by ETSI of products, services or organizations associated with those trademarks.

---

## Foreword

This European Standard (EN) has been produced by ETSI Technical Committee Satellite Earth Stations and Systems (SES).

INTERNATIONAL STANDARD PREVIEW  
(standards.iteh.ai)

<b>National transposition dates</b>	
Date of adoption of this EN:	20 September 2017
Date of latest announcement of this EN (doa):	31 December 2017
Date of latest publication of new National Standard or endorsement of this EN (dop/e):	30 June 2018
Date of withdrawal of any conflicting National Standard (dow):	30 June 2018

---

## Modal verbs terminology

In the present document "**shall**", "**shall not**", "**should**", "**should not**", "**may**", "**need not**", "**will**", "**will not**", "**can**" and "**cannot**" are to be interpreted as described in clause 3.2 of the [ETSI Drafting Rules](#) (Verbal forms for the expression of provisions).

"**must**" and "**must not**" are **NOT** allowed in ETSI deliverables except when used in direct citation.

# 1 Scope

The present document applies to the Telemetry, Command and Ranging (TCR) system of Communication Satellites (geosynchronous or not), operating in the following frequency bands:

- 5 725 MHz to 7 025 MHz uplink, 3 400 MHz to 4 200 MHz and 4 500 MHz to 4 800 MHz downlink ("C-band");
- 12 750 MHz to 13 250 MHz, 13 750 MHz to 14 800 MHz and 17 300 MHz to 18 400 MHz uplink, 10 700 MHz to 12 750 MHz and 13 400 MHz to 13 650 MHz downlink ("Ku-band");
- 27 500 MHz to 30 000 MHz uplink, 17 700 MHz to 20 200 MHz downlink ("Commercial Ka-band").

Although not explicitly addressed in the present document, possible usage in other bands allocated to FSS/MSS/BSS/SOS between 1 GHz to 51,4 GHz may be envisaged.

The TCR receiver and transmitter can have a frequency flexibility capability over a given RF band, Typical frequency step is 100 kHz.

The present document sets out the minimum performance requirements and technical characteristics of the ground/satellite Radio Frequency (RF) interface based on Frequency Modulation (FM), Phase Modulation (PM) and Code Division Multiple Access (CDMA).

With the growing number of satellites, the co-location constraints and the maximization of bandwidth for Communications Missions, real and potential interference cases have motivated the elaboration of the present document for geostationary satellites based on CDMA techniques.

The present document addresses the following applications:

- Telemetry.
- Command (Telecommand).
- Ranging.
- Hosted Payload Management.

**ITh STANDARD PREVIEW**  
(standards.iteh.ai)

[SIST EN 301 926 V1.3.1:2017](https://standards.iteh.ai/catalog/standards/sist/d765312a-46fd-4d86-bf66-c1b50d57457b/sist-en-301-926-v1-3-1-2017)

<https://standards.iteh.ai/catalog/standards/sist/d765312a-46fd-4d86-bf66-c1b50d57457b/sist-en-301-926-v1-3-1-2017>

The aim of the present document is to replace and enhance the prior document ETSI EN 301 926 [i.2] (V1.2.1). The present document's provisions also apply for use cases of autonomous control of hosted payloads. It is recognized that hosted payloads may require only a subset of the functionality.

The present document applies to the typical TCR scenario shown on figure 1. The scenario includes multiple satellites, which may be located in the same orbital location (GSO), or that can be in common view of a given TCR station during NGSO phases (such as transfer phase to GEO, or during NGSO operations). These satellites may be controlled by m different TCR ground stations. The TCR links defined in the present document have also to coexist with the communication ground terminals also shown on figure 1. Some of the satellites to be controlled may use FM/PM waveforms, and some may use a CDMA waveform, as defined later in the present document.

The scenario may also include, for some of the satellites, hosted payloads, which can be controlled independently of the satellite platform and of the main payload.

The present document defines the modulation and coding on the TCR and HPM links. Modulation formats are specified in clause 4 and coding in clause 7.



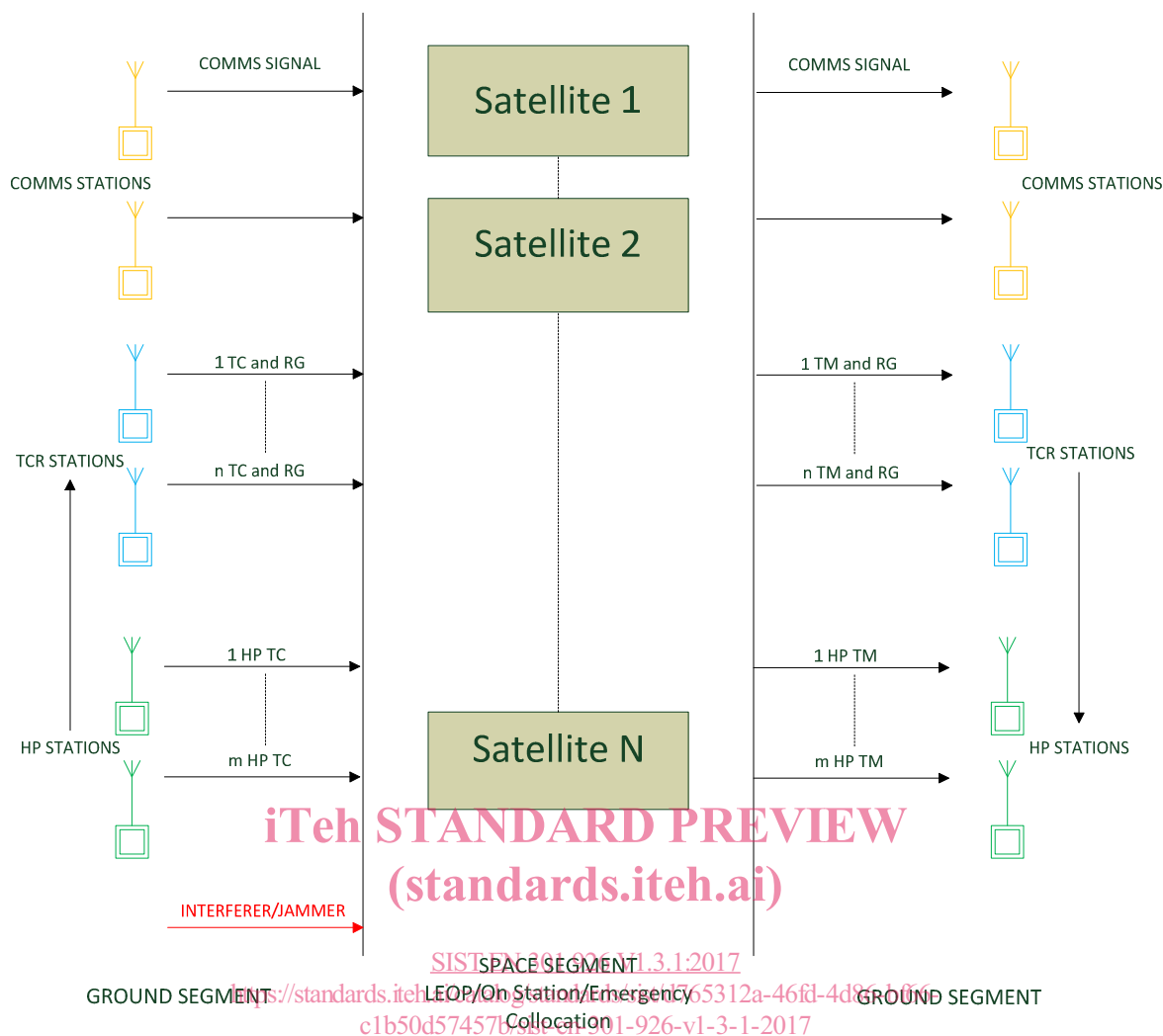

Figure 1: Communications satellites scenario

## 2 References

### 2.1 Normative references

References are either specific (identified by date of publication and/or edition number or version number) or non-specific. For specific references, only the cited version applies. For non-specific references, the latest version of the referenced document (including any amendments) applies.

Referenced documents which are not found to be publicly available in the expected location might be found at <https://docbox.etsi.org/Reference/>.

NOTE: While any hyperlinks included in this clause were valid at the time of publication, ETSI cannot guarantee their long term validity.

The following referenced documents are necessary for the application of the present document.

- [1] CCSDS 231.0-B-x: "TC Synchronization and Channel Coding".
- [2] CCSDS 131.0-B-x: "TM Synchronization and Channel Coding".

NOTE: CCSDS standards always include the issue number on their numbering system; the parameter 'x' on references [1] and [2] is understood as the highest published number and therefore latest issue of the standard.

## 2.2 Informative references

References are either specific (identified by date of publication and/or edition number or version number) or non-specific. For specific references, only the cited version applies. For non-specific references, the latest version of the referenced document (including any amendments) applies.

NOTE: While any hyperlinks included in this clause were valid at the time of publication, ETSI cannot guarantee their long term validity.

The following referenced documents are not necessary for the application of the present document but they assist the user with regard to a particular subject area.

- [i.1] ETSI TR 101 956: "Satellite Earth Stations and Systems (SES); Technical analysis of Spread Spectrum Solutions for Telemetry Command and Ranging (TCR) of Geostationary Communications Satellites".
- [i.2] ETSI EN 301 926 (V1.2.1) (06-2002): "Satellite Earth Stations and Systems (SES); Radio Frequency and Modulation Standard for Telemetry, Command and Ranging (TCR) of Geostationary Communications Satellites".

---

## 3 Definitions and abbreviations

### 3.1 Definitions

For the purposes of the present document, the following terms and definitions apply:

**binary channel:** binary communications channel (BPSK has 1 channel, QPSK has 2 channels)

**channel symbol rate:** rate of binary elements, considered on a single wire, after FEC coding and channel allocation

NOTE: See figures 3, 4 and 5. This applies only to multi-channel modulations, thus to spread spectrum QPSK modes and not to PM/FM modes.

**Co-located Equivalent Capacity (CEC):** number of collocated satellites that can be controlled with a perfect power balanced link between the ground and the satellite

**Code Division Multiple Access (CDMA):** technique for spread-spectrum multiple-access digital communications that creates channels through the use of unique code sequences

**Command Link Transmission Unit (CLTU):** telecommand protocol data structure providing synchronization for the codeblock and delimiting the beginning of user data

NOTE: See [1], section 4 for further details.

**data rate:** total number of uncoded data bits per second after packet and frame encoding

NOTE: See figures 2, 3, 4 and 5. This is the Data Rate used in Link Budgets in ETSI TR 101 956 [i.1].

**Direct Sequence Spread Spectrum (DSSS):** form of modulation where a combination of data to be transmitted and a known code sequence (chip sequence) is used to directly modulate a carrier, e.g. by phase shift keying

**symbol rate:** rate of binary elements, considered on a single wire, after FEC coding

NOTE: See figures 2 to 5.

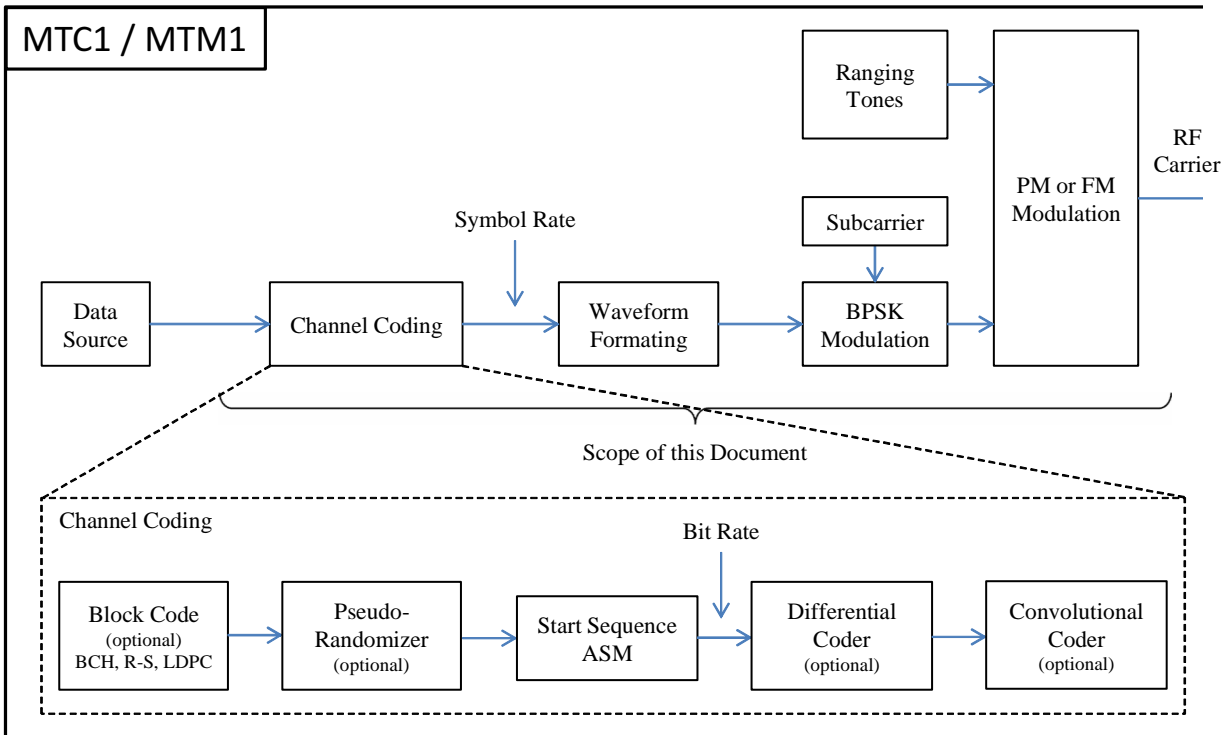

Figure 2: Functional stages of transmit chain for FM/PM modulation (MTC1/MTM1)

**iTeh STANDARD PREVIEW**  
 (standards.iteh.ai)

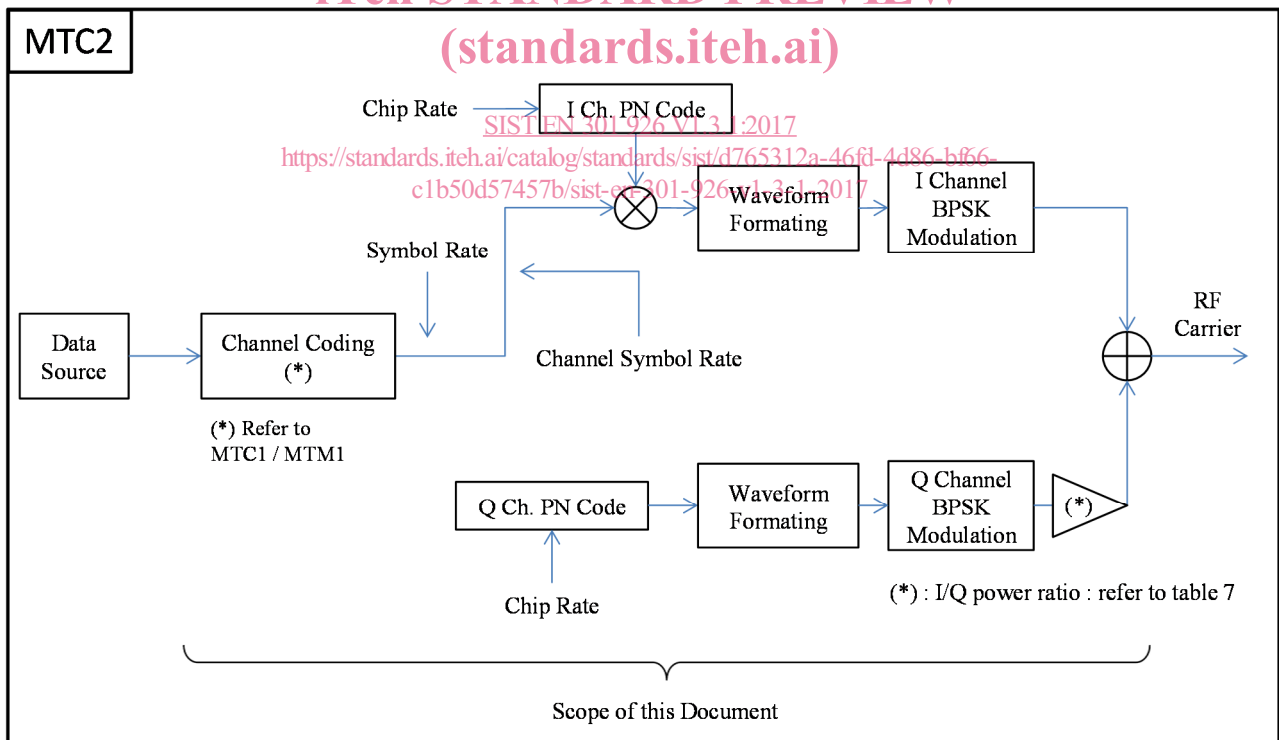

Figure 3: Functional stages of transmit chain for spread spectrum modulation MTC2

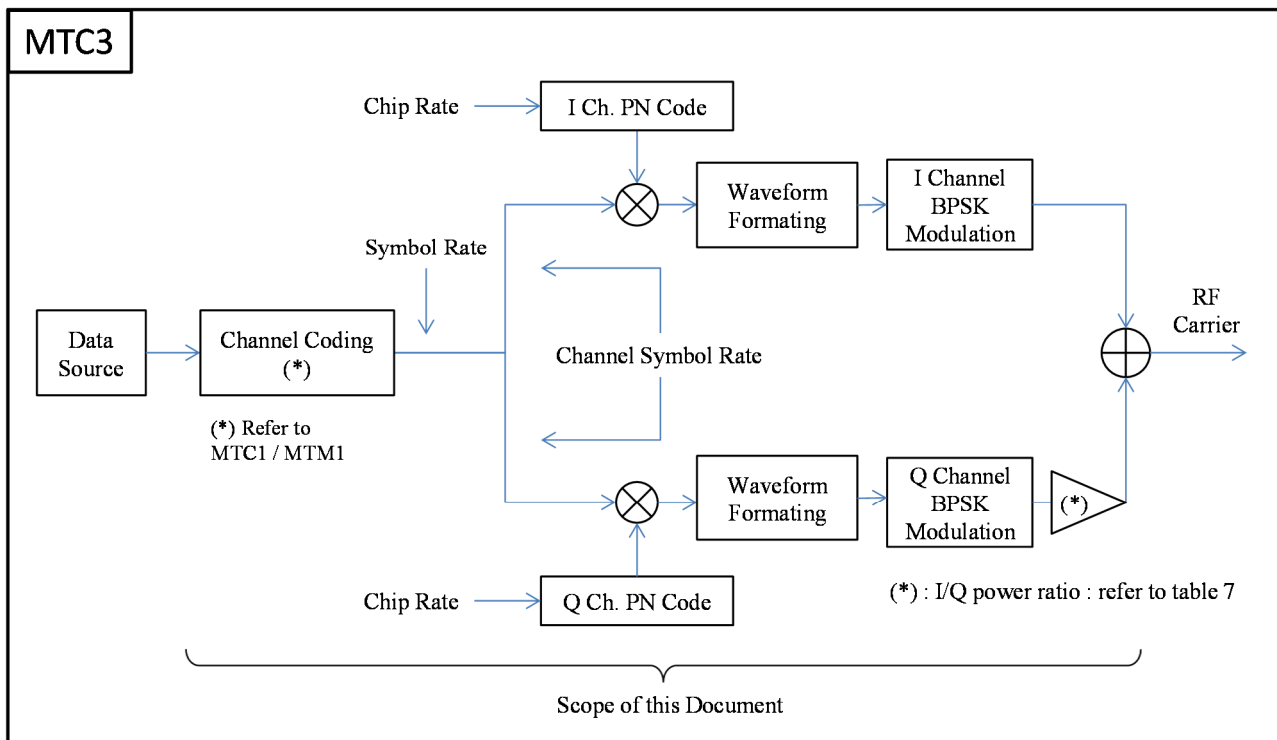

Figure 4: Functional stages of transmission chain for spread spectrum modulation MTC3

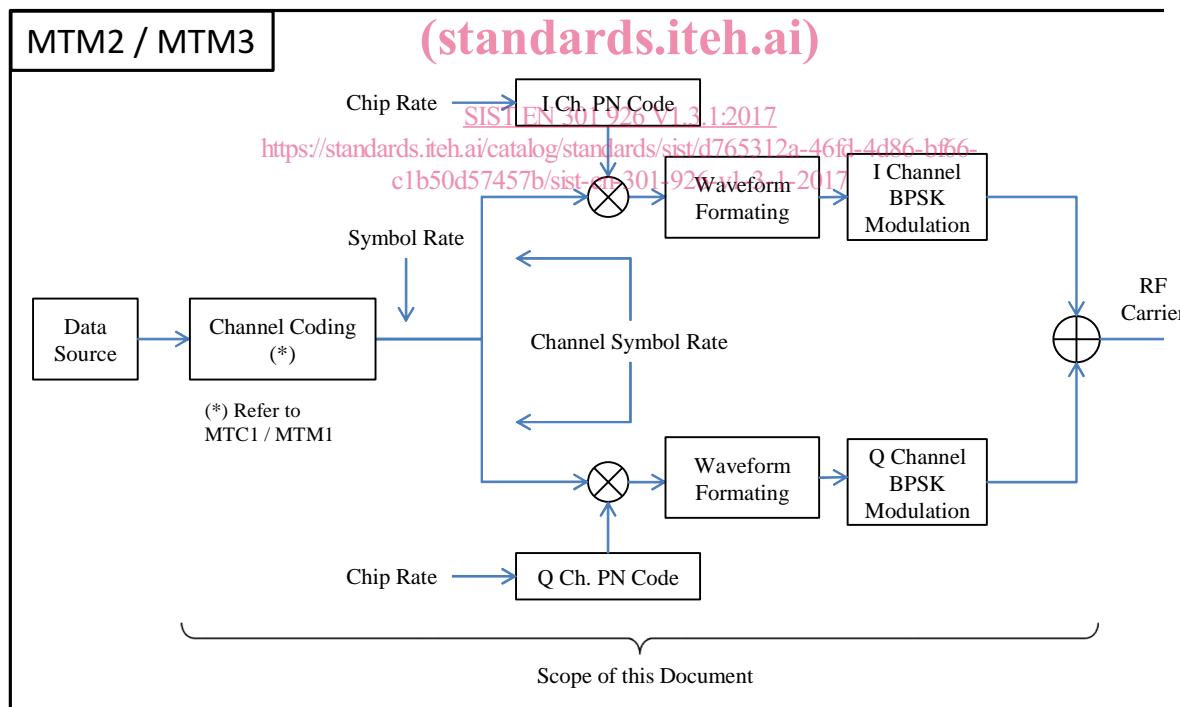

Figure 5: Functional stages of transmission chain for spread spectrum modulation MTM2/MTM3

## 3.2 Abbreviations

For the purposes of the present document, the following abbreviations apply:

BCH	Bose-Chaudhuri-Hocquenghem
BPSK	Binary Phase Shift Keying
BSS	Broadcast Satellite Service
CDMA	Code Division Multiple Access
CEC	Co-located Equivalent Capacity
CLTU	Command Link Transmission Unit
CMM	Carrier Modulation Modes
COM	Communication channel
CW	Continuous Wave
dBc	decibels relative to the carrier
dBsd	decibels relative to the maximum value of power spectral density
DSSS	Direct Sequence Spread Spectrum
EOL	End of Life
ESA	European Space Agency
FEC	Forward Error Correction
FM	Frequency Modulation
FSS	Fixed Satellite Service
GEO	Geosynchronous Earth Orbit
GSO	Geostationary Satellite Orbit
HP	Hosted Payload
HPA	High Power Amplifier
HPIU	Hosted Payload Interface Unit
HPM	Hosted Payload Management
ITU	International Telecommunication Union
LDPC	Low Density Parity Check
LEOP	Launch and Early Orbit Phase
LSB	Least Significant Bit
MAI	Multiple Access Interference
MSB	Most Significant Bit
MSS	Mobile Satellite Service
MTC1	TeleCommand Mode 1
MTC2	TeleCommand Mode 2
MTC3	TeleCommand Mode 3
MTM1	TeleMetry Mode 1
MTM2	TeleMetry Mode 2
MTM3	TeleMetry Mode 3
NA	Not Applicable
NGSO	Non Geostationary Satellite Orbit
NRZ	Non-Return to Zero
NRZ-L	Non Return to Zero-Level
NRZ-M	Non Return to Zero-Mark
OQPSK	Offset Quaternary Phase Shift Keying
PCM	Pulse Coded Modulation
PDF	Probability Density Function
PLOP	Physical Layer Operating Procedures
PM	Phase Modulation
PN	Pseudo Noise
PSD	Power Spectral Density
QPSK	Quaternary Phase Shift Keying
RF	Radio Frequency
RG	Ranging
SOS	Space Operation Service
SP-L	Split Phase-Level (alias Bi- $\Phi$ -Level or Manchester encoded)
sps	symbol per second
SRRC	Square Root Raised Cosine
SS	Spread Spectrum
TC	TeleCommand

TCR	Telemetry, Command and Ranging
TM	TeleMetry
UQPSK	Unbalanced Quaternary Phase Shift Keying
w.r.t	with respect to

## 4 Modulation Requirements

### 4.1 General

The generic system functional block diagram is shown in figure 6. Modulation modes and configurations are shown in table 1.

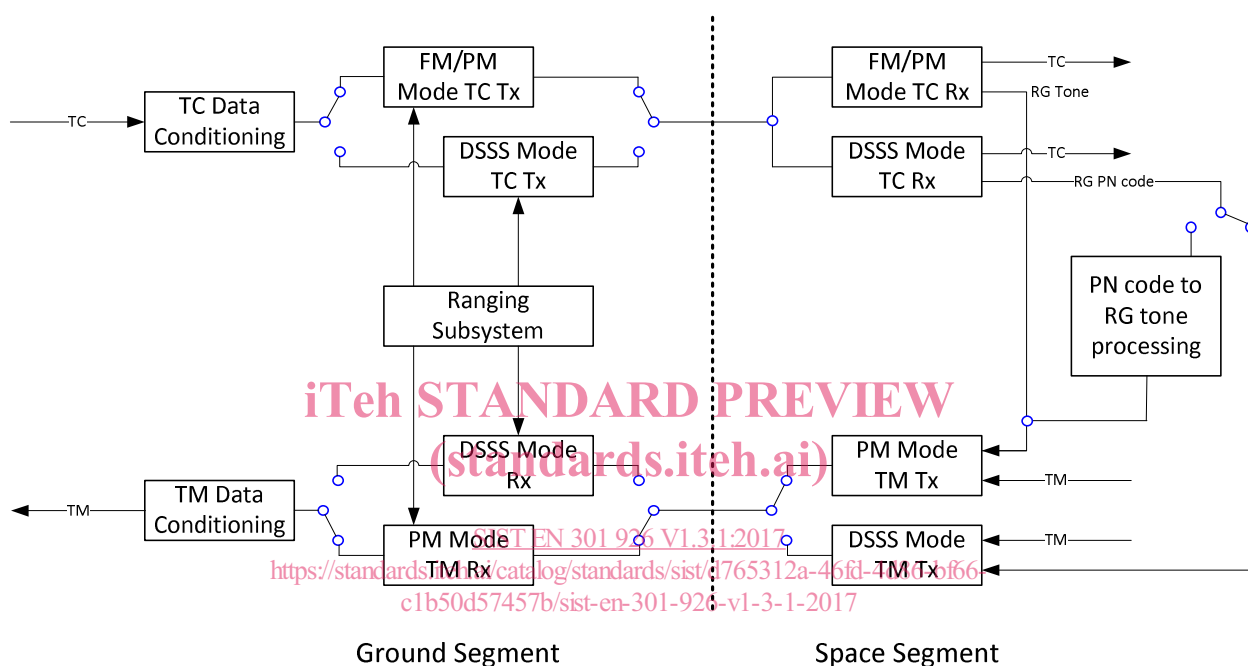

Figure 6: Generic system functional block diagram

Table 1: Modulation modes and potential configurations

	All FM/PM mode	All spread mode	Hybrid mode
Uplink	MTC1: PCM/BPSK/FM or PCM/BPSK/PM or PCM(SP-L)/PM	MTC2/MTC3: PCM/SRRC-UQPSK	MTC2/MTC3: PCM/SRRC-UQPSK
Downlink (with ranging (see note): requires uplink present)	MTM1: PCM/BPSK/PM	MTM2: PCM/SRRC-OQPSK (PN code clock/epoch sync to uplink clock/epoch)	MTM1: PCM/BPSK/PM
Downlink (without ranging: can operate without uplink present)	MTM1: PCM/BPSK/PM	MTM3: PCM/SRRC-OQPSK (PN code clock/epoch independent of uplink clock/epoch)	MTM1: PCM/BPSK/PM
NOTE: Further definition of ranging signals is given in following clauses.			

In order to retain backward compatibility with existing ground networks and to allow simple operation during LEOP, in addition to the more recent Spread Spectrum modes, the existing FM/PM modulation modes are kept. It is envisaged that telecommand and telemetry modulation formats shall be independently configurable, allowing for example the following configuration possibilities (see also annex A for implementations and ETSI TR 101 956 [i.1]):

- all standard mode (as has existed in previous systems) using tone ranging on FM uplink (MTC1) and PM (MTM1) downlink;

- all spread mode (Direct Sequence Spread Spectrum: DSSS) using PN spreading code regenerative ranging on suppressed carrier up-and down-links (MTC2/MTC3 and MTM2);
- hybrid mode using PN spreading code ranging on suppressed carrier DSSS uplink (MTC2), and tone ranging on PM downlink (MTM1).

On the spread spectrum (DSSS) mode downlink, there are 2 PN code sets defined, for coherent and non-coherent modes (modes MTM2 and MTM3 respectively). The physical partitioning of the functions may not exactly follow that shown in the system functional block diagram. The modulation configuration of the various modes is described in the rest of clause 4. Possible allocation of modes to mission phases is defined in annex A.

On the spread spectrum (DSSS) mode uplink, there are two modes defined: MTC2 and MTC3. MTC2 is the uplink mode from document ETSI EN 301 926 (V1.2.1) [i.2] in 2002. MTC3 is an add-on mode that could be used in case of an aggravated multiple access interference (MAI) environment. MTC2 and MTC3 modulation characteristics along with acquisition and tracking schemes are introduced in clause 4.3.1.

## 4.2 Frequency and Phase Modulations

### 4.2.1 Modulating waveforms

The following modulating waveforms are permitted:

- Telemetry (mode MTM1): a sine wave sub carrier, itself BPSK modulated by PCM data.
- Telecommand (mode MTC1): a sine wave subcarrier, itself BPSK modulated by PCM data.

NOTE: Except for SP-L between 8 ksps and 64 ksps (direct modulation).

- Ranging (mode MTC1 + MTM1): an unmodulated sine wave subcarrier or combination of a number of such subcarriers.

[SIST EN 301 926 V1.3.1:2017](https://standards.iteh.ai/catalog/standards/sist/d765312a-46fd-4d86-bf66-c1b50d57457b/sist-en-301-926-v1-3-1-2017)

<https://standards.iteh.ai/catalog/standards/sist/d765312a-46fd-4d86-bf66-c1b50d57457b/sist-en-301-926-v1-3-1-2017>