



Standard Specification for Warping Heads, Rope Handling (Gypsy Head, Capstan Head)¹

This standard is issued under the fixed designation F1106; the number immediately following the designation indicates the year of original adoption or, in the case of revision, the year of last revision. A number in parentheses indicates the year of last reapproval. A superscript epsilon (ϵ) indicates an editorial change since the last revision or reapproval.

1. Scope

1.1 This specification covers warping heads used with windlass, winch, and capstan drive units to pull rope on board ships. Warping heads are primarily for use with fiber rope, natural, or synthetic.

1.2 Warping heads with external ribs or whelps on the barrel, notched flanges, attached storage drums, unfinished drums, or non heat-treated fabrications, are considered special and are permitted within the scope of this specification when fully described under special ordering information.

1.3 The values stated in inch-pound units are to be regarded as the standard. The values given in parentheses are for information only.

2. Referenced Documents

2.1 ASTM Standards:²

A27/A27M Specification for Steel Castings, Carbon, for General Application

A36/A36M Specification for Carbon Structural Steel

A53/A53M Specification for Pipe, Steel, Black and Hot-Dipped, Zinc-Coated, Welded and Seamless

A148/A148M Specification for Steel Castings, High Strength, for Structural Purposes

A501 Specification for Hot-Formed Welded and Seamless Carbon Steel Structural Tubing

A724/A724M Specification for Pressure Vessel Plates, Carbon-Manganese-Silicon Steel, Quenched and Tempered, for Welded Pressure Vessels

A735/A735M Specification for Pressure Vessel Plates, Low-Carbon Manganese-Molybdenum-Columbium Alloy Steel, for Moderate and Lower Temperature Service

E10 Test Method for Brinell Hardness of Metallic Materials

2.2 AWS Standard:

D 1.1 Structural Welding Code³

2.3 ANSI Standard:

ASA B 46.1 Surface Texture⁴

2.4 Military Standards:

Fed-Spec T-R-605 Manila, Three Strand⁵

MIL-R-24050 Nylon, Double Braided⁵

3. Definitions of Terms Specific to This Standard

3.1 *barrel*—cylindrical or conical midbody portion of a warping head.

3.1.1 *Discussion*—The barrel may have a uniform diameter through the length or may be tapered from one end to the other.

3.2 *flanges*—circumferential rims at the ends of the barrel used to retain wraps of rope on the barrel portion of the warping head.

3.3 *rope contact surfaces*—portions of the barrel, flanges, and connecting fillets that a rope will contact when led in tangent to the barrel and normal to the shaft centerline, wrapped around the barrel, and led away tangent to the barrel as in normal use. (See Fig. 1 and Fig. 2.)

3.4 *warping head (also known as a gypsy head or capstan head)*—cylindrical or conical rotating member to receive multiple wraps of rope around the circumference of the member and of suitable strength to impart a pulling motion to the rope by friction contact when the member is rotated.

4. Classification

4.1 The size of the warping head shall be identified by the nominal barrel diameter measured at the smallest point of the barrel.

4.2 Warping heads under this specification are furnished in two types as follows:

¹ This specification is under the jurisdiction of ASTM Committee F25 on Ships and Marine Technology and is the direct responsibility of Subcommittee F25.03 on Outfitting and Deck Machinery.

Current edition approved May 1, 2006. Published May 2006. Originally approved in 1987. Last previous edition approved in 1998 as F1106 – 87 (1998). DOI: 10.1520/F1106-87R06.

² For referenced ASTM standards, visit the ASTM website, www.astm.org, or contact ASTM Customer Service at service@astm.org. For *Annual Book of ASTM Standards* volume information, refer to the standard's Document Summary page on the ASTM website.

³ Available from American Welding Society, 550 N.W. Le Jeune Rd., Miami, FL 33126.

⁴ Available from American National Standards Institute (ANSI), 25 W. 43rd St., 4th Floor, New York, NY 10036.

⁵ Available from Superintendent of Documents, U.S. Government Printing Office, Washington, DC 20402.

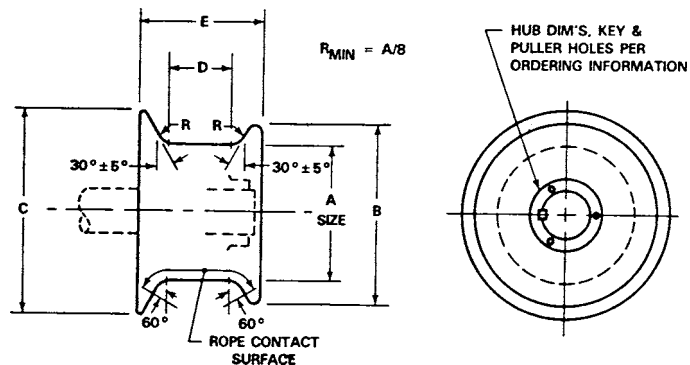

A Diameter, in.	Rope Pull, 1000 lb	B Diameter, in.	C Diameter, in.	D Length, in.	E Length, in.	Tolerance, in. ± ^A	Concentricity, in. ^B
6	12.5	8	9 ¹ / ₁₆	2 ³ / ₄	5 ¹⁵ / ₃₂	1/4	1/8
9	25.0	12	13 ⁹ / ₁₆	4 ¹ / ₁₆	8 ³ / ₁₆	3/8	3/16
12	37.5	16	18 ³ / ₁₆	5 ⁷ / ₁₆	10 ³¹ / ₃₂		
15	50.0	20	22 ³ / ₄	6 ³ / ₄	13 ¹¹ / ₁₆	1/2	1/4
18	75.0	24	27 ⁵ / ₁₆	8 ¹ / ₁₆	16 ¹³ / ₃₂		
21	100.0	28	31 ⁷ / ₈	9 ⁷ / ₁₆	19 ⁹ / ₁₆	5/8	5/16
24	125.0	32	36 ³ / ₈	10 ¹³ / ₁₆	21 ⁷ / ₈		
27	150.0	36	41 ¹⁵ / ₁₆	12 ³ / ₁₆	24 ³¹ / ₃₂	3/4	3/8
30	175.0	40	45 ¹ / ₂	13 ¹ / ₂	27 ³ / ₈		
33	200.0	44	50 ¹ / ₁₆	14 ¹³ / ₁₆	30 ⁹ / ₃₂	7/8	7/16
36	225.0	48	54 ³ / ₈	16 ³ / ₁₆	32 ⁷ / ₈		

^A Tolerance for dimensions A, B, C, D, and E.

^B Concentricity of rope contact surface and flanges relative to bore.

NOTE 1—1 in. = 25.4 mm.

FIG. 1 Type I Warping Head

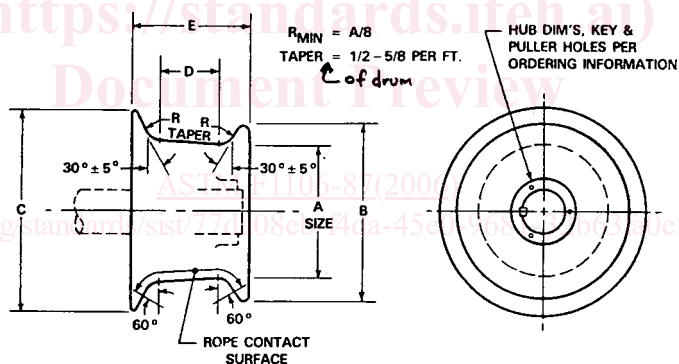

A Diameter, in.	Rope Pull, 1000 lb	B Diameter, in.	C Diameter, in.	D Length, in.	E Length, in.	Tolerance, in. ± ^A	Concentricity, in. ^B
6	12.5	8	9 ¹ / ₄	2 ³ / ₄	5 ¹⁵ / ₃₂	1/4	1/8
9	25.0	12	13 ¹⁵ / ₁₆	4 ¹ / ₁₆	8 ³ / ₁₆	3/8	3/16
12	37.5	16	18 ⁵ / ₈	5 ⁷ / ₁₆	10 ³¹ / ₃₂		
15	50.0	20	23 ¹ / ₄	6 ³ / ₄	13 ¹¹ / ₁₆	1/2	1/4
18	75.0	24	27 ⁷ / ₈	8 ¹ / ₁₆	16 ¹³ / ₃₂		
21	100.0	28	32 ⁹ / ₁₆	9 ⁷ / ₁₆	19 ⁹ / ₁₆	5/8	5/16
24	125.0	32	37 ³ / ₁₆	10 ¹³ / ₁₆	21 ⁷ / ₈		
27	150.0	36	41 ⁷ / ₈	12 ³ / ₁₆	24 ³¹ / ₃₂	3/4	3/8
30	175.0	40	46 ¹ / ₂	13 ¹ / ₂	27 ³ / ₈		
33	200.0	44	51 ¹ / ₈	14 ¹³ / ₁₆	30 ⁹ / ₃₂	7/8	7/16
36	225.0	48	55 ¹³ / ₁₆	16 ³ / ₁₆	32 ⁷ / ₈		

^A Tolerance for dimensions A, B, C, D, and E.

^B Concentricity of rope contact surface and flanges relative to bore.

NOTE 1—1 in. = 25.4 mm.

FIG. 2 Type II Warping Head