

ETSI TS 103 146-4 V1.1.1 (2017-01)



Reconfigurable Radio Systems (RRS); Mobile Device (MD) information models and protocols; Part 4: Radio Programming Interface (RPI)

PREVIEW
Full standard available at
<https://standards.iteh.ai/catalog/standards/sist/e2168791-61fd-4fc2-bc01-3a6b6a68b8e8/etsi-ts-103-146-v1.1.1-2017-01>

Reference

DTS/RRS-0248

Keywords

architecture, mobile, radio, SDR, software

ETSI

650 Route des Lucioles
F-06921 Sophia Antipolis Cedex - FRANCE

Tel.: +33 4 92 94 42 00 Fax: +33 4 93 65 47 16

Siret N° 348 623 562 00017 - NAF 742 C
Association à but non lucratif enregistrée à la
Sous-Préfecture de Grasse (06) N° 7803/88

Important notice

The present document can be downloaded from:
<http://www.etsi.org/standards-search>

The present document may be made available in electronic versions and/or in print. The content of any electronic and/or print versions of the present document shall not be modified without the prior written authorization of ETSI. In case of any existing or perceived difference in contents between such versions and/or in print, the only prevailing document is the print of the Portable Document Format (PDF) version kept on a specific network drive within ETSI Secretariat.

Users of the present document should be aware that the document may be subject to revision or change of status. Information on the current status of this and other ETSI documents is available at
<https://portal.etsi.org/TB/ETSIDeliverableStatus.aspx>

If you find errors in the present document, please send your comment to one of the following services:
<https://portal.etsi.org/People/CommitteeSupportStaff.aspx>

Copyright Notification

No part may be reproduced or utilized in any form or by any means, electronic or mechanical, including photocopying and microfilm except as authorized by written permission of ETSI.

The content of the PDF version shall not be modified without the written authorization of ETSI.
The copyright and the foregoing restriction extend to reproduction in all media.

© European Telecommunications Standards Institute 2017.
All rights reserved.

DECT™, **PLUGTESTS™**, **UMTS™** and the ETSI logo are Trade Marks of ETSI registered for the benefit of its Members.
3GPP™ and **LTE™** are Trade Marks of ETSI registered for the benefit of its Members and of the 3GPP Organizational Partners.
GSM® and the GSM logo are Trade Marks registered and owned by the GSM Association.

Contents

Intellectual Property Rights	4
Foreword.....	4
Modal verbs terminology.....	4
1 Scope	5
2 References	5
2.1 Normative references	5
2.2 Informative references.....	5
3 Definitions and abbreviations.....	6
3.1 Definitions.....	6
3.2 Abbreviations	7
4 Introduction	8
5 System Requirement Mapping	9
6 Radio Virtual Machine specification.....	10
6.1 Concept of RVM	10
6.2 Elementary RVM (eRVM).....	11
6.3 RVM Hierarchy.....	15
6.4 Data types.....	16
6.4.1 Types and Values.....	16
6.4.2 Run-Time Data	16
6.5 Arithmetic.....	17
6.6 Exceptions	17
6.7 Control, Synchronization and Execution.....	17
6.8 Operations with Memory.....	18
6.9 RVM run-time environment.....	18
7 Configcodes for RVM.....	18
7.0 Introduction	18
7.1 Configcodes generation.....	18
7.2 Binary format for Configcodes.....	20
7.3 XML schema for Configcodes.....	23
8 Radio Library	29
8.0 Introduction	29
8.1 Reference Radio Library	30
8.2 Native Radio Library.....	31
9 Loading, Linking and Initialization.....	31
10 Compiling for RVM (Front-End Compilation).....	32
Annex A (informative): Mapping between XML and Binary	33
Annex B (informative): SFB Candidate	34
Annex C (informative): Replacement of selected components of an existing RAT	36
Annex D (informative): Introducing new SFBs	37
History	38

Intellectual Property Rights

IPRs essential or potentially essential to the present document may have been declared to ETSI. The information pertaining to these essential IPRs, if any, is publicly available for **ETSI members and non-members**, and can be found in ETSI SR 000 314: "*Intellectual Property Rights (IPRs); Essential, or potentially Essential, IPRs notified to ETSI in respect of ETSI standards*", which is available from the ETSI Secretariat. Latest updates are available on the ETSI Web server (<https://ipr.etsi.org>).

Pursuant to the ETSI IPR Policy, no investigation, including IPR searches, has been carried out by ETSI. No guarantee can be given as to the existence of other IPRs not referenced in ETSI SR 000 314 (or the updates on the ETSI Web server) which are, or may be, or may become, essential to the present document.

Foreword

This Technical Specification (TS) has been produced by ETSI Technical Committee Reconfigurable Radio Systems (RRS).

The present document is part 4 of a multi-part deliverable. Full details of the entire series can be found in part 1 [i.3].

Modal verbs terminology

In the present document "**shall**", "**shall not**", "**should**", "**should not**", "**may**", "**need not**", "**will**", "**will not**", "**can**" and "**cannot**" are to be interpreted as described in clause 3.2 of the [ETSI Drafting Rules](#) (Verbal forms for the expression of provisions).

"**must**" and "**must not**" are **NOT** allowed in ETSI deliverables except when used in direct citation.

1 Scope

The scope of the present document is to define the Radio Programming Interface (RPI) for mobile device reconfiguration. The work is based on the Use Cases defined in ETSI TR 102 944 [i.1], on the system requirements defined in ETSI EN 302 969 [1] and on the radio reconfiguration related architecture for mobile devices defined in ETSI EN 303 095 [i.2]. Furthermore, the present document complements the mobile device information models and protocols related to the Multiradio Interface ETSI EN 303 146-1 [i.3], to the Reconfigurable Radio Frequency Interface ETSI EN 303 146-2 [i.4] and to the Unified Radio Application Interface ETSI EN 303 146-3 [i.5].

2 References

2.1 Normative references

References are either specific (identified by date of publication and/or edition number or version number) or non-specific. For specific references, only the cited version applies. For non-specific references, the latest version of the referenced document (including any amendments) applies.

Referenced documents which are not found to be publicly available in the expected location might be found at <https://docbox.etsi.org/Reference/>.

NOTE: While any hyperlinks included in this clause were valid at the time of publication, ETSI cannot guarantee their long term validity.

The following referenced documents are necessary for the application of the present document.

- [1] ETSI EN 302 969 (V1.2.1): "Reconfigurable Radio Systems (RRS); Radio Reconfiguration related Requirements for Mobile Devices".

2.2 Informative references

References are either specific (identified by date of publication and/or edition number or version number) or non-specific. For specific references, only the cited version applies. For non-specific references, the latest version of the referenced document (including any amendments) applies.

NOTE: While any hyperlinks included in this clause were valid at the time of publication, ETSI cannot guarantee their long term validity.

The following referenced documents are not necessary for the application of the present document but they assist the user with regard to a particular subject area.

- [i.1] ETSI TR 102 944: "Reconfigurable Radio Systems (RRS); Use Cases for Baseband Interfaces for Unified Radio Applications of Mobile Device".
- [i.2] ETSI EN 303 095 (V1.2.1): "Reconfigurable Radio Systems (RRS); Radio Reconfiguration related Architecture for Mobile Devices".
- [i.3] ETSI EN 303 146-1: "Reconfigurable Radio Systems (RRS); Mobile Device Information Models and Protocols; Part 1: Multiradio Interface (MURI)".
- [i.4] ETSI EN 303 146-2 : "Reconfigurable Radio Systems (RRS); Mobile Device (MD) information models and protocols; Part 2: Reconfigurable Radio Frequency Interface (RRFI)".
- [i.5] ETSI EN 303 146-3: "Reconfigurable Radio Systems (RRS); Mobile Device (MD) information models and protocols; Part 3: Unified Radio Application Interface (URAI)".

3 Definitions and abbreviations

3.1 Definitions

For the purposes of the present document, the following terms and definitions apply:

Abstract Processing Element (APE): abstracts computational resource that executes any computations downloaded from Radio Library

NOTE: APE is connected with input and output DOs. APE is reactive. Any computations are started if all input DOs are filled with real data.

basic operations: operations either provided by the Radio Library and/or UDFB Set to eRVM or by the Radio Library and/or RVM/eRVM Configcodes to RVM

NOTE: Each Basic Operation is mapped to a corresponding APE in the case of eRVM or mapped to a corresponding APE or RVM/eRVM in the case of RVM.

data flow chart: reactive data flow computational model consisting of data and operators where data are connected with operators

NOTE: Operators abstract computations. They are triggered by full data. Results of operator computations are written in connected output data if they are empty.

Data Object (DO): typeless token abstracting any type of data

NOTE: DO provides a container for storing data. It can be empty if no data in the container or it can be full if there is data in the container. DO is allocated in the infinite and flat memory. Any RVM has access to this memory. One or a few APEs from RVM can be connected with DO. DO acknowledges connected APEs about its status whether it empty or full.

dynamic operation: operation that is performed by allocating the computational resources during run-time for each APE required executing the given operation

NOTE 1: The resources are deallocated upon completion of the corresponding operation

NOTE 2: Dynamic operation is available only in the case of MDRC-7 defined in ETSI EN 302 969 [1]. In other words, dynamic operation is needed when RA requires the dynamic resource sharing.

native radio library: library providing platform-specific description of each SFB that represents the target platform hardware

port configuration: specification of the number of APEs inputs and outputs

radio library authority: authority empowered to decide which components can be registered as new SFBs

NOTE: Any suitable organization can take the role of a Radio Library Authority. The choice of the organization is beyond the scope of the present document.

reference radio library: library providing normative definition of each SFB

NOTE: There may be multiple such Reference Radio Libraries. For a given RA, a unique Reference Radio Library is used.

Radio Virtual Machine (RVM): abstract machine that supports reactive and concurrent executions

NOTE: A RVM may be implemented as a controlled execution environment that allows the selection of a trade-off between flexibility of base band code development and required (re-)certification efforts.

Radio Virtual Machine Runtime Environment (RVM RE): software that allows running Radio Applications that might be Configcodes or executable codes

Software Intermediate Representation (SWIR): RA representation as data flow chart

NOTE: SWIR file contains information on all terminal objects, their parameters (cost, implement function, size, etc.) and connections (links, access type, source and destination).

terminal operation: operation that will always be executed without any other interruption

NOTE 1: Furthermore, terminal operation cannot be decomposed into smaller operations.

NOTE 2: "Terminal operations" are equivalent to "atomic operations", but additionally it indicates that a hierarchy is being used in which the "terminal operations" are on the lowest level of hierarchy and they can be part of another operation.

3.2 Abbreviations

For the purposes of the present document, the following abbreviations apply:

AOT	Ahead-Of-Time
APE	Abstract Processing Element
ASF	Abstract Switch Fabric
BE	Back End
CC	Configcodes Counter
CSL	Communication Services Layer
CU	Control Unit
DO	Data Object
eRVM	Elementary RVM
eSFB	Elementary SFB
FB	Functional Block
FBRI	FB Reusability Index
FFT	Fast Fourier Transform
HD	Hardware Dimension
HW	Hardware
ID	Identification
IFFT	Inverse Fast Fourier Transform
IR	Intermediate Representation
JIT	Just-In-Time
LCF	Last Configuration Flag
MD	Mobile Device
MURI	MUltiRadio Interface
NAF	Next Address Flag
NCAO	Next Configcode Address Offset
RA	Radio Application
RAP	Radio Application Package
RAT	Radio Access Technology
RCF	Radio Control Framework
RE	Runtime Environment
RF	Radio Frequency
RLA	Radio Library Authority
ROS	Radio Operating System
RPI	Radio Programming Interface
RRFI	Reconfigurable Radio Frequency Interface
RVM RE	RVM Runtime Environment
RVM	Radio Virtual Machine
SD	Software Dimension
SFB	Standard Functional Block
SWIR	SoftWare Intermediate Representation
UDFB	User Defined Functional Block
UML®	Unified Modeling Language
URA	Unified Radio Applications
URAI	Unified Radio Applications Interface
XML	eXtensible Markup Language

4 Introduction

A reconfigurable MD is capable of running multiple radios simultaneously and of changing the set of radios by loading new Radio Application Package (RAP). All Radio Applications (RAs) are called Unified Radio Applications (URAs) when they exhibit a common behaviour from the reconfigurable MD's point of view [i.2]. In order to run multiple URAs, the reconfigurable MD will include Communication Services Layer (CSL), Radio Control Framework (RCF), Radio Platform and 4 sets of interfaces for their interconnection.

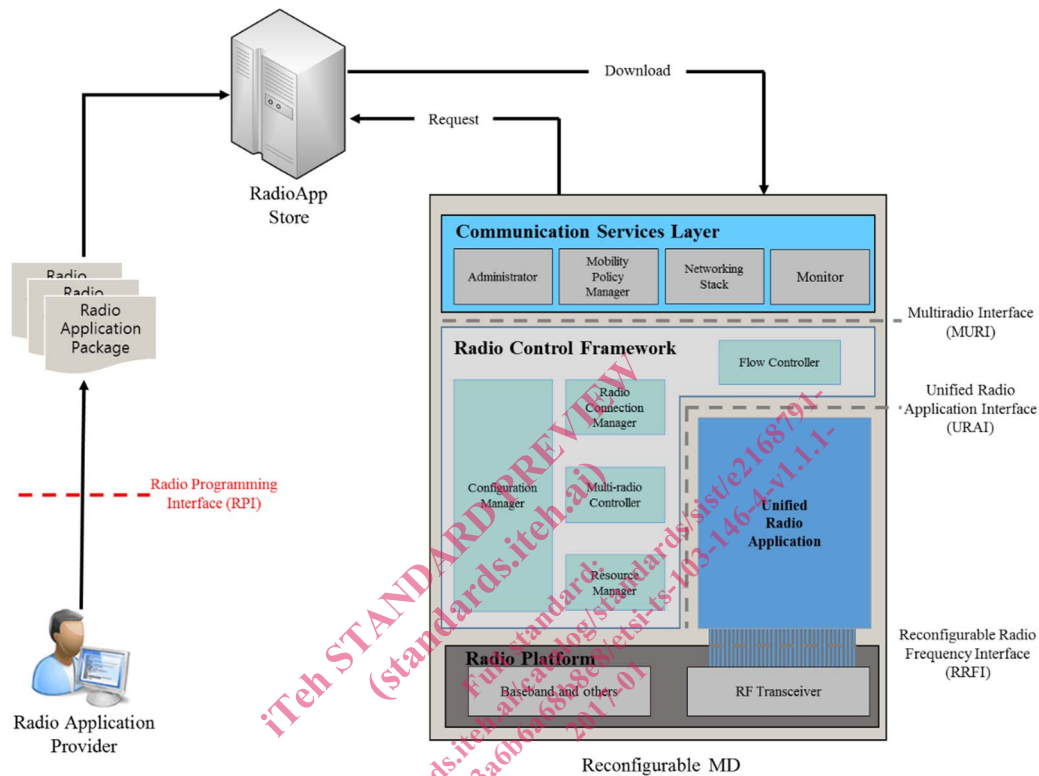

Figure 4.1: Four sets of interfaces for Reconfigurable MD

Figure 4.1 illustrates the Reconfigurable MD architecture with the 4 sets of interfaces, i.e.:

- MURI for interfacing CSL and RCF [i.2];
- RRFI for interfacing URA and RF Transceiver [i.3];
- URAI for interfacing URA and RCF [i.2];
- RPI for allowing an independent and uniform production of RAs.

The present document defines RPI.

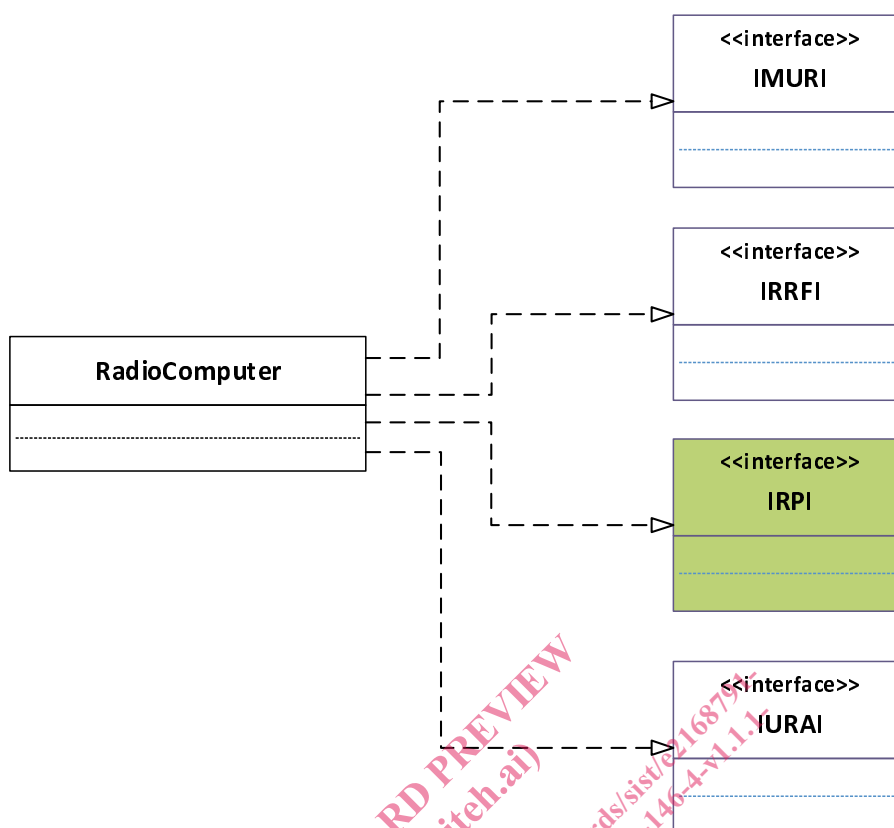

Figure 4.2: UML® class diagram for Radio Computer interfaces

Figure 4.2 illustrates UML® class diagram for Radio Computer interfaces. The reconfigurable MD may be seen as a Radio Computer where individual URAs are engineered as software entities [i.2].

The present document is organized as follows:

- Clause 5 describes the system requirement mapping;
- Clause 6 describes the radio virtual machine specification;
- Clause 7 describes the Configcodes for RVM;
- Clause 8 describes the radio library structure;
- Clause 9 describes the load, linking and initialization;
- Clause 10 describes the compiling for RVM;
- Annex A describes the mapping between Binary and XML;
- Annex B describes SFB Candidates;
- Annex C describes the replacement of selected components of an existing RAT.

While UML® is used for defining the information model and protocol related to RPI, other modelling languages could be used as well.

5 System Requirement Mapping

The Radio Programming Interface and its related components described in the present document shall support the system requirements shown in table 5.1 referring to clause 6 of ETSI EN 302 969 [1]. This is achieved by introducing the entities/components/units given in the 1st column of table 5.1.

Table 5.1: Mapping of Radio Programming Interface and its related components to the system requirements described in ETSI EN 302 969 [1]

Entity/Component/Unit	System Requirements [1]	Comments
Radio Programming Interface	R-FUNC-MDR-04	The requirement shall be as described in clause 6.4.4 of ETSI EN 302 969 [1].
Radio Virtual Machine	R-FUNC-MDR-13	The requirement shall be as described in clause 6.4.13 of ETSI EN 302 969 [1].
	R-FUNC-MDR-14	The requirement shall be as described in clause 6.4.14 of ETSI EN 302 969 [1].
	R-FUNC-MDR-15	The requirement shall be as described in clause 6.4.15 of ETSI EN 302 969 [1].
Radio Library	R-FUNC-FB-06	A library extension shall be supported. The requirement shall be as described in clause 6.3.6 of ETSI EN 302 969 [1].

6 Radio Virtual Machine specification

6.1 Concept of RVM

As introduced in ETSI EN 303 095 [i.2], the Radio Virtual Machine (RVM) is an Abstract Machine which is capable of executing Configcodes and it is independent of the hardware. The implementation of a RVM is target Radio Computer specific and it shall have access to the Back-end Compiler (on the platform itself or externally as described in ETSI EN 303 095 [i.2], clause 4.4.1) for Just-in-Time (JIT) or Ahead-of-Time (AOT) compilation of Configcodes.

This clause describes the concept of RVM. As mentioned above, the RVM is an abstract machine, which executes a particular algorithm presented as a data flow chart. In other words, the RVM is the result of replacing all operators and tokens in the particular data flow chart with Abstract Processing Elements (APEs) and Data Objects (DOs), respectively. Each APE executes computations marked by the replaced operator identifier. These computations are taken from the Radio Library.

Figure 6.1 illustrates a conceptual view of RVM processing. This process requires APE, DO and Radio Library, of which the definitions are as follows:

- APE abstracts a computational resource corresponding to the operation in a particular data flow chart.
- DO abstracts a memory resource. In other words, DO is an abstracted memory for storing data used during the procedure of Radio processing.
- Reference/Native Radio Library includes normative definitions/native implementation of all Standard Functional Blocks (SFBs) [i.2] for front-end/back-end compilation. Note that the computations included in the Radio Library are represented in terms of normative definitions or native implementations of SFBs depending upon whether the Radio Library is used for front-end or back-end compilation, respectively.

NOTE 1: User Defined Functional Blocks (UDFBs) will be created through combination of SFBs and represented as a data flow chart to be executed in the RVM. Alternatively, a UDFB is implemented as a stand-alone module/function which can be mapped:

- into one APE (i.e. this UDFB can be considered atomic); or
- into an eRVM/RVM (i.e. not atomic). UDFBs are not in general included into the Radio Library, but they are part of the Radio Application Package.

The RVM begins to work immediately after some DOs initialization. All APEs shall execute computations asynchronously and concurrently. An individual APE shall execute the allocated operator if all the corresponding input DOs are full. APEs shall access DOs with operations "read", "read-erase", or "write". After reading input data from DOs, the APE shall execute the allocated operator and, if output DOs are empty, then the APE shall write processed data. Any full output DO shall block the corresponding writing operation. The RVM shall execute computations until reaching the state when all APEs become inactive. In this state, there are not enough full DOs, which can activate the inactive operators. The result of computations are full DOs, which cannot activate the inactive operators.

NOTE 2: An Output DO can become an Input DO for a subsequent operator. Then, this input DO can activate the subsequent operator.

NOTE 3: The state or operation of a given APE is independent on the state of other APEs. I.e. each APE is atomic.

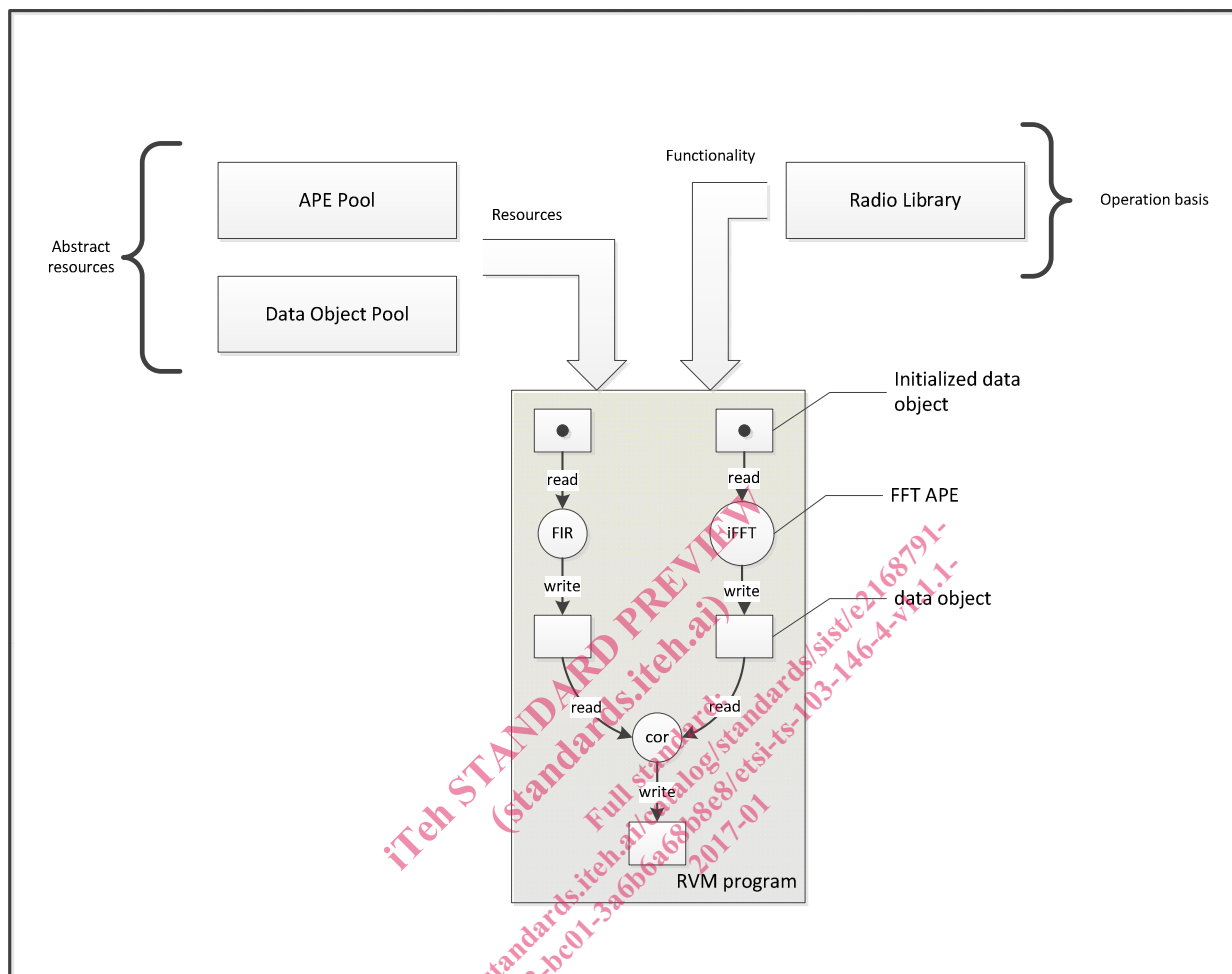

Figure 6.1: Conceptual Diagram of Radio Virtual Machine Processing

6.2 Elementary RVM (eRVM)

This clause describes the eRVM which shall consist of components of Basic Operations, Program memory, Control Unit (CU), Abstract Switch Fabric (ASF) as well as APEs and DOs, of which the definitions are as follows. eRVM shall not contain another eRVM or RVM.

- Basic Operations shall include operators either provided:
 - i) from Radio Library as SFBs and/or;
 - ii) from UDFB set as UDFBs, each of which is mapped onto one single APE.

NOTE 1: Since UDFBs might be implemented as a stand-alone module/function which can be mapped into one APE, in this case, Basic Operations include operators provided by UDFB Set as well as by Radio Library as SFBs. Note that those UDFBs are atomic.

NOTE 2: For a RVM, the SFB or UDFB can be mapped onto an APE or RVM or eRVM. In the eRVM case, the mapping to RVM or eRVM is not possible since it is the lowest level of hierarchy as it will be introduced in clause 6.3.

NOTE 3: From an execution perspective, there is no difference between SFBs and UDFBs.