



Standard Test Method for Softening Point of Asphalt and Pitch (Mettler Cup-and-Ball Method)¹

This standard is issued under the fixed designation D 3461; the number immediately following the designation indicates the year of original adoption or, in the case of revision, the year of last revision. A number in parentheses indicates the year of last reapproval. A superscript epsilon (ϵ) indicates an editorial change since the last revision or reapproval.

1. Scope

1.1 This test method covers the determination of the softening point of asphalt and pitch in the range from 50 to 180°C by the cup-and-ball apparatus, and gives results comparable to those obtained by Test Method D 36.

NOTE 1—If the softening point of asphalt by this Mettler cup-and-ball method fails to meet specified requirements, tests may be rerun using the Test Method D 36 (ring-and-ball) softening point apparatus as a referee method.

1.2 *This standard does not purport to address all of the safety concerns, if any, associated with its use. It is the responsibility of the user of this standard to establish appropriate safety and health practices and determine the applicability of regulatory limitations prior to use.*

2. Referenced Documents

2.1 ASTM Standards:

- A 314 Specification for Stainless Steel Billets and Bars for Forgings²
- D 36 Test Method for Softening Point of Bitumen (Ring-and-Ball Apparatus)³
- D 140 Practice for Sampling Bituminous Materials⁴
- D 4296 Practice for Sampling Pitch⁵

3. Summary of Test Method

3.1 In this test method the softening point is defined as the temperature at which the specimen, suspended in a cylindrical cup with a 6.5-mm hole in the bottom and with a lead ball, 8 mm in diameter, centered on top of the sample in the cup, flows downward a distance of 19 mm to interrupt a light beam, as the sample is heated at a linear rate in air.

¹ This test method is under the jurisdiction of ASTM Committee D02 on Petroleum Products and Lubricants and is the direct responsibility of Subcommittee D02.05.OF on Industrial Pitches.

Current edition approved July 10, 1997. Published October 1997. Originally published as D 3461 – 76. Last previous edition D 3461 – 85 (1994) ^{ϵ 2}.

² *Annual Book of ASTM Standards*, Vol 01.03.

³ *Annual Book of ASTM Standards*, Vol 04.04.

⁴ *Annual Book of ASTM Standards*, Vol 04.03.

⁵ *Annual Book of ASTM Standards*, Vol 05.02.

4. Significance and Use

4.1 Asphalt and pitch do not go through a solid-liquid phase change when heated, and therefore do not have true melting points. As the temperature is raised, they gradually soften or become less viscous. For this reason, the determination of the softening point must be made by an arbitrary, but closely defined, method if the test values are to be reproducible.

4.2 This test method is useful in determining the consistency as one element in establishing the uniformity of shipments or sources of supply.

5. Apparatus

5.1 A Mettler dropping point cell⁶ can be used to determine softening points by this test method. These commercially available instruments consist of a control unit with a digital temperature indicator, matched furnace, sample cartridges, and accessories. The control unit automatically regulates the heating rate of the furnace. The softening point is indicated on the readout, and the heating program stopped, when the sample flow triggers a photocell detector. A general view of the components of the Mettler apparatus is shown in Fig. 1.

5.1.1 *Control Unit*—This unit shall provide a continuous, linear temperature increase from 25 to 250°C at a rate of 2°C/min. A digital readout shall indicate the temperature to 0.1°C throughout.

5.1.2 *Furnace Unit*—This unit shall be capable of heating a specimen cup assembly, as described in 5.1.3, at a linear rate of $2 \pm 0.3^\circ\text{C}/\text{min}$. It shall include a sensing system capable of detecting the softening point with a precision of 0.1°C.

5.1.3 *Specimen Cup Assembly*—A cup of chromium-plated brass, or stainless steel conforming to the requirements for Type 303 (UNS 530300) as prescribed in Specification A 314, with dimensions shown in Fig. 2. It shall be placed in the assembly so that the test specimen will flow down a distance of 19 mm before interrupting a light beam and stopping the heating program as the softening point is reached.

⁶ Available from the Mettler Toledo, Inc., Balances and Instruments, 69 Princeton-Hightstown Rd., Hightstown, NJ 08520-0071.

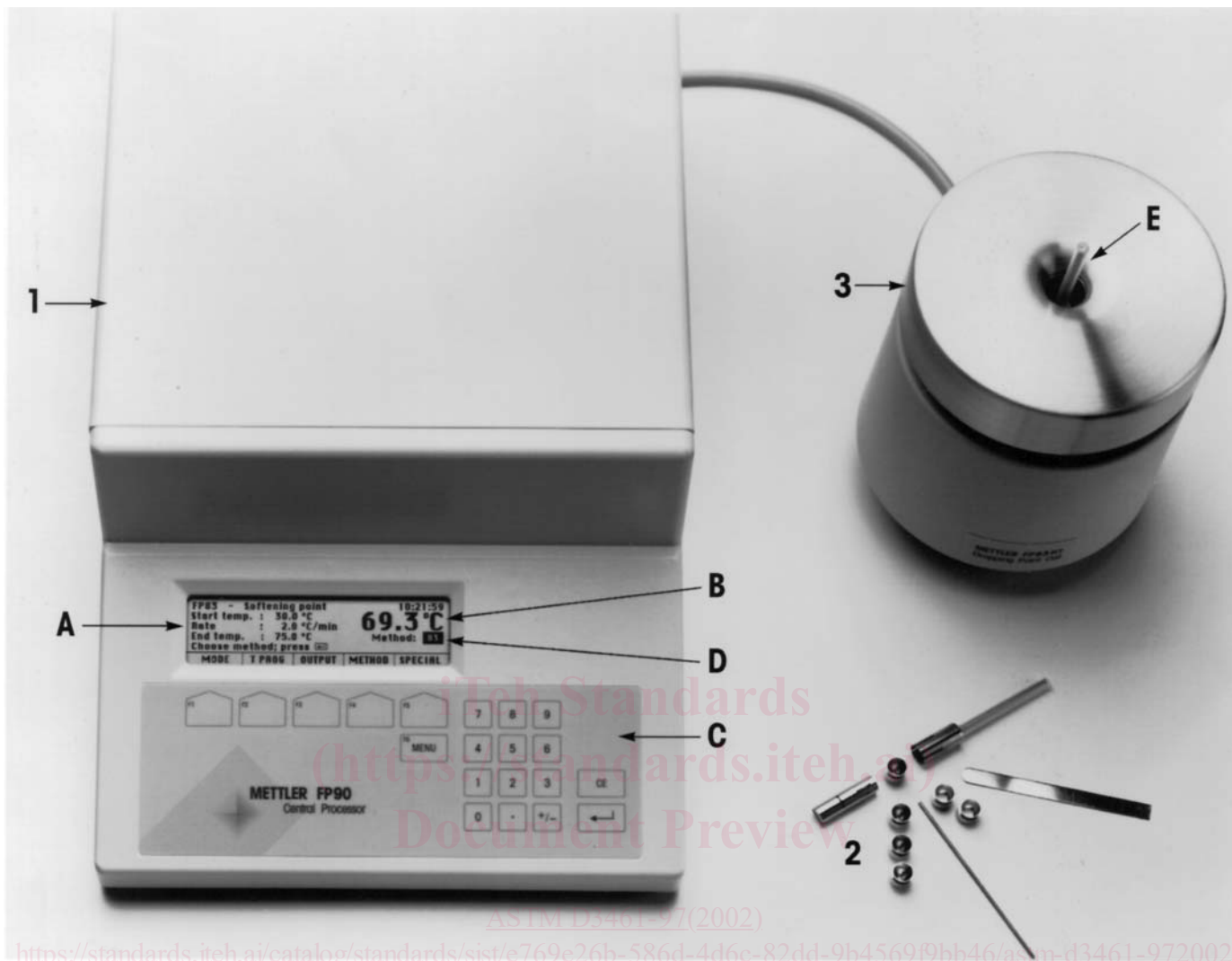

General View of the METTLER TOLEDO FP90/FP83HT

- | | |
|--|-------------------------------|
| 1 Control and evaluation unit | 2 Cartridges with accessories |
| A LCD with guide for operator | 3 Measuring cell FP83HT |
| B Temperature display | E Sample holder |
| C Keyboard with function keys F1 to F6 | |
| D Selected method number | |

FIG. 1 General View of the Mettler FP-5/53

5.1.4 *Lead Ball*—A lead ball weighing 3.20 ± 0.10 g. A32-caliber lead shot is suitable for this purpose.

6. Reagents

6.1 *Xylene*, industrial grade.

7. Calibration of Mettler Apparatus

7.1 This step, required only occasionally, is designed to establish that the temperature indicated by the instrument is in agreement with a known standard. A special cup with a bottom orifice of 2.8 mm is used instead of the one prescribed for the specimen testing.

7.2 *Reagent*—Use either analytical reagent or primary standard grade benzoic acid for this calibration. As this material is

hygroscopic, it must be stored in a tightly sealed container, and replaced with fresh material from a newly opened supply if hydration or other contamination is suspected.

7.3 Procedure:

7.3.1 *Filling the Specimen Cup*—Place the cup on a clean, flat surface. Add a small amount of benzoic acid crystals and press down with a rod (4.5 mm in diameter). Check that the bottom orifice is completely filled. Refill and repeat the pressing step until the cup is filled with benzoic acid. Remove any crystals from the exterior of the cup.

7.3.2 *Heating*—Preheat the Mettler furnace to 121°C, and maintain it at that temperature. Place the cartridge assembly containing the benzoic acid in position in the furnace, taking care that the slits for the light beam are properly positioned.

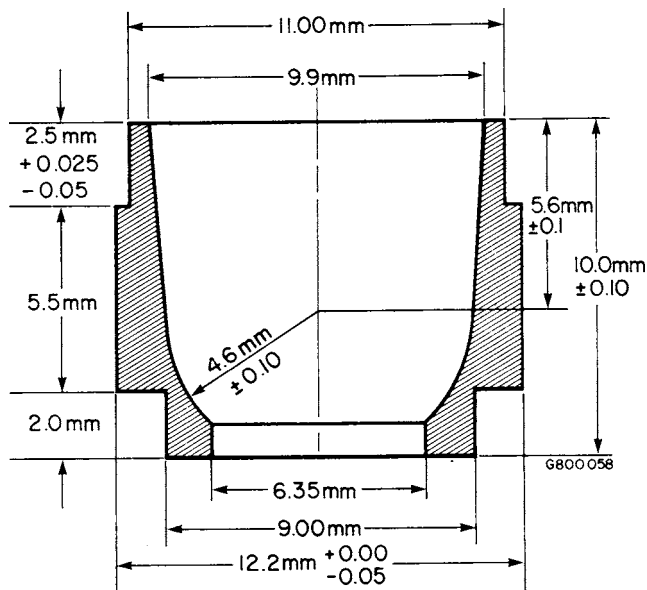

FIG. 2 Specimen Cup

Wait for temperature equilibration, that is, the furnace and the sample are in equilibrium at the preset temperature, but not less than 30 s after inserting the cartridge, start the automatic heating cycle at 0.2°C/min. The temperature will rise steadily at the correct rate until the drop point is reached, and then remain steady on the readout.

7.3.3 *Cleaning*—Immediately remove the cartridge assembly. Check to determine that the specimen has passed through the light beam and no pretriggering has occurred. If a malfunction is suspected, the entire procedure must be repeated. Inspect the apparatus carefully to ensure that no residue remains. Use a spatula shaped to the contour of the cup to remove most of the remaining acid from the cup and from the bottom of the cartridge. Wash the cup and cartridge in xylene, or other suitable solvent, to remove the last traces of the residue.

7.3.4 *Interpretation*—If the result is not $123.5 \pm 0.5^\circ\text{C}$, repeat the test. If the second value is 0.6°C above or below 123.5°C, measure the dropping point of a fresh specimen of benzoic acid. If the deviation exceeds 0.6°C, the instrument requires recalibration or repair. Consult the manufacturer's instruction manual.

8. Sampling

8.1 Samples from shipments shall be taken in accordance with Practice D 140 for asphalt and Practice D 4296 for pitch and shall be free of foreign substances. Thoroughly mix the sample before removing a representative portion for the determination or for dehydration.

8.2 Pitch Sample Preparation:

8.2.1 If a solid bulk sample contains free water, air-dry a representative portion at 60°C or below.

8.2.2 If the sample is liquid, check for any surface foam which may indicate the presence of water. If foam is found, maintain the sample at a temperature of about 125°C in an open container until the surface is free of foam. Take care not to

overheat. Remove from the heat source as soon as the foam has subsided. Proceed as directed in 9.1.

8.2.3 Crush air-dry lumps of pitch to a size of 6 to 12 mm. Add the material to a container, having a height equal to or exceeding its width, and having a volume of not less than 50 mL, until it is about half full. Place the container on a hot plate, or in an oven or a bath. Do not use an open flame for melting pitch. After melting is complete, stir gently but thoroughly, avoiding incorporation of air bubbles. The maximum temperature of the molten pitch should not exceed the expected softening point by more than 50°C. Any foam that forms must be skimmed off.

8.3 Asphalt Sample Preparation:

8.3.1 Heat the sample, with care to prevent local overheating, constantly stirring until it has become sufficiently fluid to pour. In no case, however, shall the temperature be raised more than 110°C (200°F) above the expected softening point for asphalt. Avoid incorporating air bubbles in the sample.

8.3.2 Bring the asphalt sample to the pouring temperature in not more than 2 h.

9. Test Specimen

9.1 Prepare the test specimen by slightly overfilling the specimen cup, which rests on a brass plate. Keep the lip of the container close to the top of the cup to minimize entrainment of air bubbles. Underpouring past the blade of a spatula is helpful in this respect. Cool the specimen in the cup until firm, under cold water if necessary. Trim the specimen flush with the top of the cup by pressing with a heated knife or spatula while drawing it toward you. Support the cup with tweezers or forceps or in a wood block with holes sized to fit the cup. Do not trim by cutting across the top with a forward or sideward motion as this tends to lift the specimen out of the mold, thus creating an internal void which is not easily detected, and which significantly alters the result.

9.2 An alternative method which avoids possible loss of volatiles in remelting, is to press the cold, solid specimen into the specimen cup. Select clean, dry, dust-free lumps from the representative portion of the sample and crush to a size of less than 2 mm. Place a sample cup in the mold (see Fig. 3, Fig. 4, and Fig. 5). Place the assembled mold, with the knockout pin in position, on the bottom plate of a hydraulic press. Pour about 2 g of the crushed specimen into the top of the mold and insert the top ram. Compress the specimen into the cup with a total force on the ram of 22.24 kN (5000 lbf). Hold this pressure for a minimum of 15 s. Excessive molding pressure can cause the specimen cup to fail by shearing. Remove the mold assembly from the press and rotate the upper half while keeping the lower half of the mold stationary. This action causes the specimen to shear horizontally at the top of the cup. Separate the two parts of the mold and remove the specimen cup from the bottom half. It may be necessary to dislodge it by pressing against the knockout pin. A small-diameter rod mounted on the base plate may be used for this. Clean the mold of all residual material to avoid misalignment or binding during subsequent use. This procedure does not work well for pitches having softening points below 80°C unless the mold is precooled below room temperature.