



Designation: ~~D 635-03~~ Designation: D 635 - 06

Standard Test Method for Rate of Burning and/or Extent and Time of Burning of Plastics in a Horizontal Position¹

This standard is issued under the fixed designation D 635; the number immediately following the designation indicates the year of original adoption or, in the case of revision, the year of last revision. A number in parentheses indicates the year of last reapproval. A superscript epsilon (ϵ) indicates an editorial change since the last revision or reapproval.

This standard has been approved for use by agencies of the Department of Defense.

1. Scope*

1.1 This fire-test-response test method covers a small-scale laboratory screening procedure for comparing the relative linear rate of burning or extent and time of burning, or both, of plastics in the form of bars, molded or cut from sheets, plates, or panels, and tested in the horizontal position.

NOTE 1—This test method, and test method A of IEC 60695-11-10 are technically equivalent.

NOTE 2—For additional information on materials which do not burn to the first reference mark by this test, see Test Method D 3801.

1.2 This test method was developed for polymeric materials used for parts in devices and appliances. The results are intended to serve as a preliminary indication of their acceptability with respect to flammability for a particular application. The final acceptance of the material is dependent upon its use in complete equipment that conforms with the standard applicable to such equipment.

1.3 The classification system described in ~~the appendix~~ Appendix X1 is intended for quality assurance and the preselection of component materials for products.

1.4 *This standard is used to measure and describe the response of materials, products, or assemblies to heat and flame under controlled conditions, but does not by itself incorporate all factors required for fire hazards or fire risk assessment of materials, products, or assemblies under actual fire conditions.*

1.5 *This standard does not purport to address all of the safety concerns, if any, associated with its use. It is the responsibility of the user of this standard to establish appropriate safety and health practices and determine the applicability of regulatory limitations prior to use. For specific hazards statements, see 9.2.1-9.2.*

2. Referenced Documents

2.1 ASTM Standards:²

D 648 [Test Method for Deflection Temperature of Plastics Under Flexural Load in the Edgewise Position](#)

D 883 [Terminology Relating to Plastics](#)²—[Terminology Relating to Plastics](#)

D 1929 [Test Method for Determining Ignition Temperature of Plastics](#)

D 2843 [Test Method for Density of Smoke from the Burning or Decomposition of Plastics](#)

D 3801 [Test Method for Measuring the Comparative Burning Characteristics of Solid Plastics in a Vertical Position](#)

D 5025 [Specification for a Laboratory Burner Used for Small-Scale Burning Tests on Plastic Materials](#)

D 5207 [Practice for Calibration of 20 and 125-mm Test Flames for Small-Scale Burning Tests on Plastic Materials](#)⁴—[Practice for Confirmation of 20mm \(50W\) and 125mm \(500W\) Test Flames for Small-Scale Burning Tests on Plastic Materials](#)

E 84 [Test Method for Surface Burning Characteristics of Building Materials](#)

E 176 [Terminology of Fire Standards](#)

E 691 [Practice for Conducting an Interlaboratory Study to Determine the Precision of a Test Method](#)

2.2 IEC Standards:

IEC 60695-11-10 [Fire Hazard Testing - Part 11-10 Test Flames - 50W Horizontal and Vertical Flame Test Methods](#)³

¹ This test method is under the jurisdiction of ASTM Committee D20 on Plastics and is the direct responsibility of Subcommittee D20.30 on Thermal Properties (Section D20.30.03).

Current edition approved July 10, 2003. Published September 2003. Originally approved in 1941. Last previous edition approved in 1998 as D635-98.

Current edition approved May 1, 2006. Published June 2006. Originally approved in 1941. Last previous edition approved in 2003 as D 635 - 03.

² Annual Book of ASTM Standards, Vol 08.01.

³ For referenced ASTM standards, visit the ASTM website, www.astm.org, or contact ASTM Customer Service at service@astm.org. For Annual Book of ASTM Standards volume information, refer to the standard's Document Summary page on the ASTM website.

⁴ Annual Book of ASTM Standards, Vol 08.02.

*A Summary of Changes section appears at the end of this standard.

3. Terminology

3.1 Definitions:

3.1.1 Definitions used in this test method are in accordance with Terminology D 883, unless otherwise specified. For terms relating to fire, the definitions used in this test method are in accordance with Terminology E 176.

4. Summary of Test Method

4.1 A bar specimen of the material to be tested is supported horizontally at one end. The free end is exposed to a specified gas flame for 30 s. Time and extent of burning are measured and reported if the specimen does not burn 100 mm. An average burning rate is reported for a material if it burns to the 100 mm mark from the ignited end.

5. Significance and Use

5.1 Tests made on a material under conditions herein prescribed are of value in comparing the rate of burning or extent and time of burning characteristics, or both, of different materials, in controlling manufacturing processes, or as a measure of deterioration or change in these burning characteristics prior to or during use. Correlation with flammability under actual use conditions is not implied.

5.2 The rate of burning and other burning phenomena will be affected by such factors as density, pigments, any anisotropy of the material and the thickness of the specimen. Test data shall be compared only for specimens of similar thickness, whether comparisons are being made with the same or different materials. The rate of burning and other burning phenomena will vary with thickness.

5.3 It is feasible that sheet materials that have been stretched during processing will relax during burning and give erratic results unless they are first heated above their deflection temperature, in accordance with Test Method D 648, for a time sufficient to permit complete relaxation.

5.4 Burning tests require that certain variables be arbitrarily fixed, for example, specimen size, energy source and application time, and end points. Materials will be found that are unusually sensitive to one or more of the conditions chosen for this method leading to highly variable results. Additional burning characterization by other methods is highly desirable in such cases (see Note 2).

5.5 In this procedure, the specimens are subjected to specific laboratory test conditions. If different test conditions are substituted or the end-use conditions are changed, it will not always be possible by or from this test to predict changes in the fire-test-response characteristics measured. Therefore, the results are valid only for the fire-test-exposure conditions described in this procedure.

6. Apparatus

6.1 *Test Chamber*, enclosed laboratory hood, or chamber free of induced or forced draft during test, having an inside volume of at least 0.5 m³. An enclosed laboratory hood with a heat-resistant glass window for observing the test and an exhaust fan for removing the products of combustion after the tests is recommended. The atmosphere in and around the test chamber shall be maintained between 15 to 35°C and 45 to 75 % relative humidity.

NOTE 3—The amount of oxygen available to support combustion is naturally important for the conduct of these fire-test-response tests. For tests conducted by this test method when burning times are protracted, chamber sizes less than 1 m³ may not provide accurate results.

NOTE 4—Some laboratory hoods have induced drafts even with the exhaust fan off. A positive-closing damper is recommended.

NOTE 5—A mirror in the chamber, to provide a rear view of the specimen, has been found useful in some enclosures.

6.2 *Test Fixture*, A laboratory ring stand or test fixture equipped with a means of holding a 125 mm² wire gauze horizontal and a small clamp permitting the specimen to be held with its longitudinal axis horizontal and its transverse axis inclined at 45 ± 2° angle as illustrated in Fig. 1.

NOTE 6—A pan of water may be placed on the floor of the hood in position to catch any burning particles that may drop during the test.

6.3 *Laboratory Burner*, constructed in accordance with Specification D 5025.

6.4 *Gas Supply*, a supply of technical-grade methane gas with suitable regulator and meter for uniform gas flow. Natural gas mixtures having an energy density of approximately 37 MJ/m³ have been found to provide similar results. However, technical-grade methane gas shall be used as the referee in cases of dispute.

6.5 *Wire Gauze*, 20-mesh (approximately 20 openings per 25 mm), made with 0.43 ± 0.03 mm diameter iron wire cut to approximately 125 mm², to sustain burning or glowing particles falling from the specimens.

6.6 *Timing Device*, accurate to 0.5 s.

6.7 *Scale*, graduated in millimetres.

6.8 *Micrometer*, accurate to 0.05 mm.

6.9 *Conditioning Room or Chamber*, capable of being maintained at 23 ± 2°C and 50 ± 5 % relative humidity.

³ Publications of the International Electrotechnical Commission (IEC) and International Organization for Standardization (ISO) are available from American National Standards Institute (ANSI), 25 W. 43rd St., 4th Floor, New York, NY 10036.

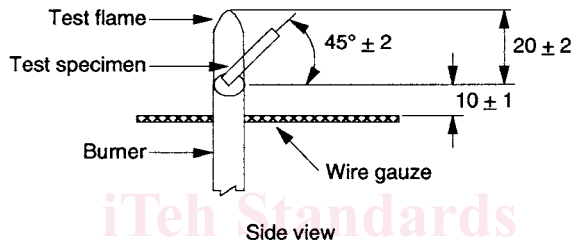
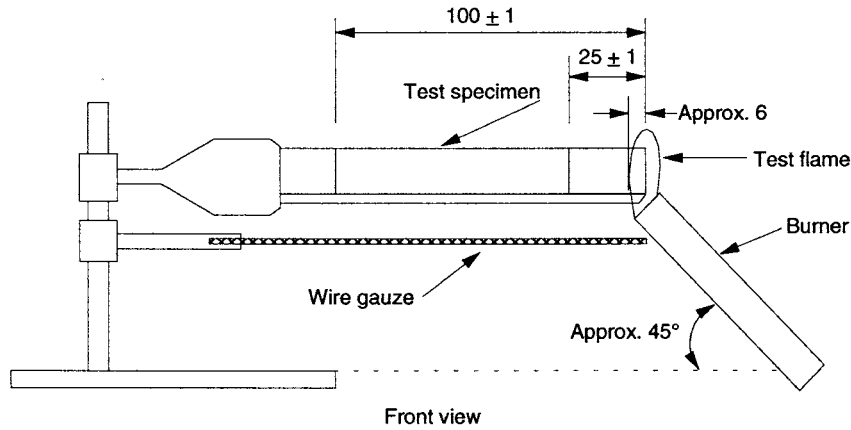

Dimensions in millimetres

FIG. 1 Test Fixture

6.10 *Flexible Specimen Support Fixture*, used to facilitate the testing of specimens that sag and touch the wire gauze. (See 9.4 and Fig. 2.)

7. Test Specimens

7.1 All test specimens shall be cut from a representative sample of the material (sheet or end products), or shall be cast or injection-, compression-, transfer- or pultrusion-molded to the necessary form. After any cutting operation, care shall be taken to remove all dust and any particles from the surface; cut edges shall be fine sanded to have a smooth finish. Unless otherwise agreed, fabrication of test specimens shall be in accordance with the specifications of the material being tested.

7.2 Specimens shall be 125 ± 5 mm long by 13.0 ± 0.5 mm wide, and provided in the minimum thickness and in the $3.0 (-0.0 +0.2)$ mm thickness. The 3.0 mm thick specimens are not necessary if the minimum thickness is greater than 3.0 mm, or the maximum thickness is less than 3.0 mm. The maximum thickness shall not exceed 13 mm. The maximum width shall not exceed 13.5 mm. The edges shall be smooth, and the radius on the corners shall not exceed 1.3 mm.

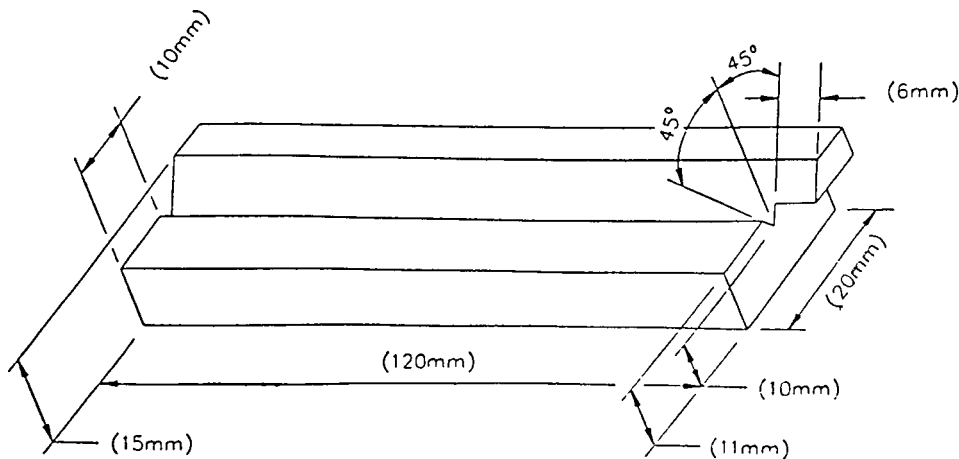

FIG. 2 Flexible Specimen Support Fixture

7.3 It is possible that the results of tests carried out on test specimens of different colors, thicknesses, densities, molecular masses, directions of anisotropy and types, or with different additives, fillers/reinforcements will be different.

7.3.1 Test specimens in the minimum and maximum densities, melt flows and level of fillers/reinforcements contents shall be considered representative of the range, if the results yield the same flame test classification. If the burning characteristics are not essentially the same for all specimens representing the range, the evaluation is to be limited only to the materials in the densities, melt flows, and fillers/reinforcements contents tested. Additional specimens in the intermediate densities, melt flows, and fillers/reinforcements contents are to be tested.

7.3.2 Uncolored test specimens and test specimens with the highest level of organic and inorganic pigment loading by weight are considered representative of the color range, if the test results are essentially the same. When certain pigments are known to affect flammability characteristics, they are also to be tested. Specimens to be tested are those that:

- (a) contain no coloring
- (b) contain the highest level of organic pigments
- (c) contain the highest level of inorganic pigments
- (d) contain pigments which are known to adversely affect flammability characteristics

8. Conditioning

8.1 Condition ten bar specimens for each material and thickness to be tested in accordance with Test Method D 618 at $23 \pm 2^\circ\text{C}$ and $50 \pm 5\%$ relative humidity for a minimum of 48 h. Once removed from the conditioning atmosphere test the specimens within 1 h.

8.2 Conduct testing in a laboratory atmosphere of 15 to 35°C and 45 to 75 % relative humidity.

9. Procedure

9.1 Prepare at least ten bar specimens. After measuring and recording the specimen thickness, mark each specimen with two lines perpendicular to the longitudinal axis of the bar, 25 ± 1 and 100 ± 1 mm from the end that is to be ignited.

9.2 Conduct the burning test in a chamber, enclosure, or laboratory hood free of induced or forced draft. ~~Note 7~~—**(Warning: Warning—**Products of combustion may be toxic. An enclosed laboratory hood and an exhaust fan for removing the products of combustion after the tests are recommended. The exhaust fan is turned off during the test and turned on immediately following the test in order to remove products of combustion.)

9.3 Clamp the specimen at the end farthest from the 25 mm reference mark, in a support with its longitudinal axis horizontal and its transverse axis inclined at $45 \pm 2^\circ$ as illustrated in Fig. 1. Clamp the wire gauze horizontally beneath the specimen, with a distance of 10 ± 1 mm between the lowest edge of the specimen and the wire gauze, and with the free end of the specimen even with the edge of the gauze. Any material remaining on the wire gauze from the previous test must be burned off or a new section of wire gauze used for each test.

9.4 If the specimen sags at its free end during the initial set up and is not able to maintain the distance of 10 ± 1 mm as specified in 9.2, the flexible specimen support fixture illustrated in Fig. 2 shall be used. Position the support fixture under the specimen with the small extending portion of the support fixture at least 20 mm from the free end of the specimen. Provide enough clearance at the clamped end of the specimen so that the support fixture can be moved freely sideways. As the flame front progresses along the specimen, withdraw the support fixture at the same approximate rate, preventing the flame front from contacting the flexible specimen support fixture, so that there is no effect on the test flame or on the burning of the specimen.

9.5 With the central axis of the burner tube in the vertical position, place the burner remote from the specimen, ignite, and adjust it to produce a blue flame 20 mm high. Adjust the gas supply and the air ports of the burner until a 20-mm yellow-tipped blue flame is produced, and then increase the air supply until the yellow tip just disappears. Measure the height of the flame. If the flame height is not 20 ± 2 mm, adjust the burner gas supply to give the proper flame height. Once the flame has been properly set to a height of 20 ± 2 mm wait for at least 5 min to allow the burner conditions to reach equilibrium.

~~NOTE 8~~—See Practice D 5207- 7—See Practice D 5207 for recommended back pressure and flow rate for the gas supply and calibration procedure for the 20 mm flame.

9.6 Place the burner so that the test flame impinges on the free end of the test specimen to a depth of approximately 6 mm starting the timing device simultaneously. The central axis of the burner tube is to be in the same vertical plane as the longitudinal bottom edge of the specimen and inclined toward the end of the specimen at an angle of approximately 45 ± 2 degrees to the horizontal. See Fig. 1. Apply the flame for 30 ± 1 s without changing its position. If the test specimen shrinks from the applied flame without ignition, the material is not suitable for evaluation by these test methods. Excessive distortion of the specimen during the test will invalidate the results. Withdraw the test flame sufficiently from the specimen (see ~~Note 9~~Note 8) so that there is no effect on the specimen after 30 ± 1 s or as soon as the flame front of the specimen reaches the 25 mm mark (if less than 30 s). Restart the timing device when the flame front reaches the 25 mm reference mark.

~~NOTE 9~~ 98—Withdrawing the burner a distance of 150 mm from the specimen has been found satisfactory.

9.7 If the specimen continues to burn, with a flame or glowing combustion (visible glow without flame), after removal of the test flame, record the elapsed time (t), in seconds, for the flame front to travel from the 25 mm reference mark to the 100 mm reference mark and record the burned length (L), as 75 mm. If the flame front passes the 25 mm reference mark but does not reach