



**iTeh STANDARD PREVIEW**  
**(standards.iteh.ai)**

[SIST ETS 300 347-3 E2:2003](https://standards.iteh.ai/catalog/standards/sist/9061f425-007e-4a78-8db3-f8ed7c9652e0/sist-ets-300-347-3-e2-2003)

<https://standards.iteh.ai/catalog/standards/sist/9061f425-007e-4a78-8db3-f8ed7c9652e0/sist-ets-300-347-3-e2-2003>



**E**UROPEAN  
**T**ELECOMMUNICATION  
**S**TANDARD

**DRAFT**  
pr **ETS 300 347-3**

December 1997

Second Edition

Source: SPS

Reference: RE/SPS-03056-3

ICS: 33.020

**Key words:** V interface, V5 interface, AN, ISDN, layer 3, LE, PSTN, testing, TSS&TP

**Signalling Protocols and Switching (SPS);  
V interfaces at the digital Local Exchange (LE);  
V5.2 interface for the support of Access Network (AN);  
Part 3: Test Suite Structure and Test Purposes (TSS&TP)  
specification for the network layer (AN side)**

**ETSI**

European Telecommunications Standards Institute

**ETSI Secretariat**

**Postal address:** F-06921 Sophia Antipolis CEDEX - FRANCE

**Office address:** 650 Route des Lucioles - Sophia Antipolis - Valbonne - FRANCE

**X.400:** c=fr, a=atlas, p=etsi, s=secretariat - **Internet:** secretariat@etsi.fr

Tel.: +33 4 92 94 42 00 - Fax: +33 4 93 65 47 16

**Copyright Notification:** No part may be reproduced except as authorized by written permission. The copyright and the foregoing restriction extend to reproduction in all media.

© European Telecommunications Standards Institute 1997. All rights reserved.

## iTeh STANDARD PREVIEW (standards.iteh.ai)

[SIST ETS 300 347-3 E2:2003](https://standards.iteh.ai/catalog/standards/sist/9061f425-007e-4a78-8db3-f8ed7c9652e0/sist-ets-300-347-3-e2-2003)

<https://standards.iteh.ai/catalog/standards/sist/9061f425-007e-4a78-8db3-f8ed7c9652e0/sist-ets-300-347-3-e2-2003>

## Contents

Foreword .....	7
1 Scope .....	9
2 Normative references .....	9
3 Definitions and abbreviations .....	10
3.1 Definitions .....	10
3.2 Abbreviations .....	10
4 Test Suite Structure (TSS) .....	11
4.1 Overview .....	11
4.2 Test groups .....	12
4.2.1 Protocol groups .....	13
4.2.1.1 Control protocol .....	13
4.2.1.2 Public Switched Telephone Network (PSTN) protocol .....	13
4.2.1.3 Link control protocol .....	13
4.2.1.4 Bearer Channel Connection (BCC) protocol .....	13
4.2.1.5 Protection protocol .....	13
4.2.2 Main test groups .....	14
4.2.2.1 Basic Interconnection tests (IT) .....	14
4.2.2.2 Capability tests (CA) .....	14
4.2.2.3 Valid Behaviour tests (BV) .....	14
4.2.2.4 Inopportune Behaviour tests (BO) .....	14
4.2.2.5 Invalid Behaviour tests (BI) .....	14
4.2.2.6 Timer expiry and counter mismatch tests (TI) .....	14
4.2.2.6.1 Timers and counters of the Control protocol .....	14
4.2.2.6.2 Timers and counters of the PSTN protocol .....	14
4.2.2.6.3 Timers and counters of the Link control protocol .....	14
4.2.2.6.4 Timers and counters of the BCC protocol .....	14
4.2.2.6.5 Timers and counters of the Protection protocol .....	14
4.2.2.6.6 Timers and counters of the AN system management .....	15
4.3 Test step structure .....	15
4.3.1 State transitions .....	15
4.3.1.1 Start-up of V5.2 interface .....	15
4.3.1.2 Common control protocol (system management) .....	17
4.3.1.3 Control protocol (PSTN port FSM) .....	17
4.3.1.4 Control protocol (ISDN-BA port FSM) .....	17
4.3.1.5 Control protocol (ISDN-PRA port FSM) .....	17
4.3.1.6 PSTN protocol .....	17
4.3.1.7 Link control protocol .....	18
4.3.1.8 BCC protocol .....	18
4.3.1.9 Protection protocol .....	18
4.3.2 Preconditions .....	18
4.3.3 Preambles .....	18
4.3.4 Postambles .....	19
4.3.5 Status verification .....	19
4.3.5.1 PSTN protocol .....	19
4.3.5.2 Link control FSM .....	19
4.3.6 Common test steps .....	19
4.4 Defaults .....	19
4.5 Abstract Service Primitives (ASPs) and Protocol Data Units (PDUs) .....	19
4.5.1 ASPs .....	19
4.5.2 PDUs .....	19
4.5.2.1 Common control protocol .....	19
4.5.2.2 Port control protocol .....	19
4.5.2.3 PSTN protocol .....	19

	4.5.2.4	Link control protocol.....	19
	4.5.2.5	BCC protocol.....	20
	4.5.2.6	Protection protocol.....	20
4.5.3		Information elements.....	20
	4.5.3.1	Variable length information elements.....	20
	4.5.3.1.1	Control protocol.....	20
	4.5.3.1.2	PSTN protocol.....	20
	4.5.3.1.3	Link control protocol.....	20
	4.5.3.1.4	BCC protocol.....	20
	4.5.3.1.5	Protection protocol.....	20
	4.5.3.2	Single octet information elements.....	21
	4.5.3.2.1	Control protocol.....	21
	4.5.3.2.2	PSTN protocol.....	21
	4.5.3.2.3	Link control protocol.....	21
	4.5.3.2.4	BCC protocol.....	21
	4.5.3.2.5	Protection protocol.....	21
4.6		Timers and counters of the Abstract Test Suite (ATS).....	21
5		Test Purposes (TPs).....	22
5.1		Introduction.....	22
	5.1.1	Test purpose naming convention.....	22
	5.1.2	Source of test purpose definition.....	23
	5.1.3	Test strategy.....	23
	5.1.3.1	Common control protocol.....	23
	5.1.3.2	Port control protocol.....	23
	5.1.3.3	PSTN protocol.....	23
	5.1.3.4	Link control protocol.....	24
	5.1.3.5	BCC protocol.....	24
	5.1.3.6	Protection protocol.....	24
	5.1.4	Requirements not covered by test purposes.....	25
	5.1.5	Initial states.....	25
	5.1.6	Test and data configuration requirements.....	25
5.2		Control protocol.....	26
	5.2.1	Basic interconnection tests (V5NWKAN/CTRL/IT).....	26
	5.2.2	Capability tests (V5NWKAN/CTRL/CA).....	26
	5.2.3	Valid behaviour tests (V5NWKAN/CTRL/BV).....	26
	5.2.3.1	V5NWKAN/CTRL/BV/COM.....	26
	5.2.3.2	V5NWKAN/CTRL/BV/PORT.....	26
	5.2.3.2.1	V5NWKAN/CTRL/BV/PORT/TRANS.....	26
	5.2.3.2.2	V5NWKAN/CTRL/BV/PORT/PSTN.....	26
	5.2.3.2.3	V5NWKAN/CTRL/BV/PORT/ISDNBA.....	27
	5.2.3.2.4	V5NWKAN/CTRL/BV/PORT/ISDNPRA.....	27
	5.2.4	Inopportune behaviour tests (V5NWKAN/CTRL/BO).....	28
	5.2.4.1	V5NWKAN/CTRL/BO/COM.....	28
	5.2.4.2	V5NWKAN/CTRL/BO/PORT.....	28
	5.2.4.2.1	V5NWKAN/CTRL/BO/PORT/TRANS.....	28
	5.2.4.2.2	V5NWKAN/CTRL/BO/PORT/PSTN.....	28
	5.2.4.2.3	V5NWKAN/CTRL/BO/PORT/ISDNBA.....	29
	5.2.4.2.4	V5NWKAN/CTRL/BV/PORT/ISDNPRA.....	29
	5.2.5	Invalid behaviour tests (V5NWKAN/CTRL/BI).....	29
	5.2.6	Timer expiry and counter mismatch tests (V5NWKAN/CTRL/TI).....	29
5.3		PSTN protocol.....	29
5.4		Link control protocol.....	29
	5.4.1	Basic interconnection tests (V5NWKAN/LINK/IT).....	29
	5.4.2	Capability tests (V5NWKAN/LINK/CA).....	29
	5.4.3	Valid behaviour tests (V5NWKAN/LINK/BV).....	30
	5.4.3.1	V5NWKAN/LINK/BV/TRANS.....	30
	5.4.3.2	V5NWKAN/LINK/BV/LINK.....	30
	5.4.4	Inopportune behaviour tests (V5NWKAN/LINK/BO).....	42
	5.4.4.1	V5NWKAN/LINK/BO/TRANS.....	42
	5.4.4.2	V5NWKAN/LINK/BO/LINK.....	42
	5.4.5	Invalid behaviour tests (V5NWKAN/LINK/BI).....	45
	5.4.5.1	V5NWKAN/LINK/BI/TRANS.....	45

5.4.6	Timer expiry and counter mismatch tests (V5NWKAN/LINK/TI).....	46
5.4.6.1	V5NWKAN/LINK/TI/TRANS .....	46
5.5	BCC protocol.....	46
5.5.1	Basic interconnection tests (V5NWKAN/BCC/IT) .....	47
5.5.2	Capability tests (V5NWKAN/BCC/CA) .....	47
5.5.3	Valid behaviour tests (V5NWKAN/BCC/BV) .....	48
5.5.4	Inopportune behaviour tests (V5NWKAN/BCC/BO).....	51
5.5.5	Invalid behaviour tests (V5NWKAN/BCC/BI) .....	52
5.5.6	Timer expiry and counter mismatch tests (V5NWKAN/BCC/TI) .....	54
5.6	Protection protocol .....	54
5.6.1	Basic interconnection tests (V5NWKAN/PROTECT/IT).....	54
5.6.2	Capability tests (V5NWKAN/PROTECT/CA) .....	55
5.6.3	Valid behaviour tests (V5NWKAN/PROTECT/BV).....	55
5.6.4	Inopportune behaviour tests (V5NWKAN/PROTECT/BO).....	60
5.6.5	Invalid behaviour tests (V5NWKAN/PROTECT/BI).....	60
5.6.6	Timer expiry and counter mismatch tests (V5NWKAN/PROTECT/TI) .....	62
Annex A (informative):	Bibliography .....	64
History.....		65

## iTeh STANDARD PREVIEW (standards.iteh.ai)

SIST ETS 300 347-3 E2:2003

<https://standards.iteh.ai/catalog/standards/sist/9061f425-007e-4a78-8db3-f8ed7c9652e0/sist-ets-300-347-3-e2-2003>

Blank page

**iTeh STANDARD PREVIEW**  
**(standards.iteh.ai)**

SIST ETS 300 347-3 E2:2003

<https://standards.iteh.ai/catalog/standards/sist/9061f425-007e-4a78-8db3-f8ed7c9652e0/sist-ets-300-347-3-e2-2003>



## Foreword

This draft second edition European Telecommunication Standard (ETS) has been produced by the Signalling Protocols and Switching (SPS) Technical Committee of the European Telecommunications Standards Institute (ETSI), and is now submitted for the Public Enquiry phase of the ETSI standards approval procedure.

This ETS is part 3 of a multi-part standard covering the V5.2 interface as described below:

- Part 1: "V5.2 interface specification";
- Part 2: "Protocol Implementation Conformance Statement (PICS) proforma";
- Part 3: "Test Suite Structure and Test Purposes (TSS&TP) specification for the network layer (AN side)";**
- Part 4: "Abstract Test Suite (ATS) and partial Protocol Implementation eXtra Information for Testing (PIXIT) proforma specification for the network layer (AN side)";
- Part 5: "Test Suite Structure and Test Purposes (TSS&TP) specification for the network layer (LE side)";
- Part 6: "Abstract Test Suite (ATS) and partial Protocol Implementation eXtra Information for Testing (PIXIT) proforma specification for the network layer (LE side)";
- Part 7: "Test Suite Structure and Test Purposes (TSS&TP) specification for the data link layer";
- Part 8: "Abstract Test Suite (ATS) and partial Protocol Implementation eXtra Information for Testing (PIXIT) proforma specification for the data link layer";
- Part 9: "Test specification for the physical layer".

SIST ETS 300 347-3 E2:2003

<https://standards.iteh.ai/catalog/standards/sist/00616125-007e-4a78-8db3-f8ed7e9652c6/sist-ets-300-347-3-e2-2003>

### Proposed transposition dates

Date of latest announcement of this ETS (doa):	3 months after ETSI publication
Date of latest publication of new National Standard or endorsement of this ETS (dop/e):	6 months after doa
Date of withdrawal of any conflicting National Standard (dow):	6 months after doa

Blank page

**iTeh STANDARD PREVIEW**  
**(standards.iteh.ai)**

SIST ETS 300 347-3 E2:2003

<https://standards.iteh.ai/catalog/standards/sist/9061f425-007e-4a78-8db3-f8ed7c9652e0/sist-ets-300-347-3-e2-2003>

## 1 Scope

This third part of ETS 300 347 contains the Test Suite Structure and Test Purposes (TSS&TP) for the network layer and parts of the system management of the Access Network (AN) side of a V5.2 interface.

The objective of this ETS is to provide conformance tests giving a high probability of inter-operability of an AN and a Local Exchange (LE) from different manufacturers over the V5.2 interface. This ETS covers only the procedures described in ETS 300 347-1 [2].

ISO/IEC 9646-1 [4] and ISO/IEC 9646-2 [5] are used as the basis for the test methodology.

This ETS needs to be read in conjunction with ETS 300 324-3 [1]. The two documents share a common format and clauses within ETS 300 324-3 [1] are directly referenced.

Annex A lists the bibliography.

## 2 Normative references

This ETS incorporates by dated and undated reference, provisions from other publications. These normative references are cited at the appropriate places in the text and the publications are listed hereafter. For dated references, subsequent amendments to or revisions of any of these publications apply to this ETS only when incorporated in it by amendment or revision. For undated references the latest edition of the publication referred to applies.

- [1] ETS 300 324-3: "Signalling Protocols and Switching (SPS); V interfaces at the digital Local Exchange (LE); V5.1 interface for the support of Access Network (AN); Part 3: Test Suite Structure and Test Purposes (TSS&TP) specification for the network layer (AN side)".
- [2] ETS 300 347-1 (1994) including amendment A1 (1997): "Signalling Protocols and Switching (SPS); V interfaces at the digital Local Exchange (LE); V5.2 interface for the support of Access Network (AN); Part 1: V5.2 interface specification".  
<https://standards.iteh.ai/catalog/standards/sist/9061f425-007e-4a78-8db3-f8ed7c9652e0/sist-ets-300-347-3-e2-2003>
- [3] ETS 300 347-2 (1994) including amendment A1 (1997): "Signalling Protocols and Switching (SPS); V interfaces at the digital Local Exchange (LE); V5.2 interface for the support of Access Network (AN); Part 2: Protocol Implementation Conformance Statement (PICS) proforma".
- [4] ISO/IEC 9646-1: "Information technology - Open systems interconnection - Conformance testing methodology and framework - Part 1: General concepts".
- [5] ISO/IEC 9646-2: "Information technology - Open systems interconnection - Conformance testing methodology and framework - Part 2: Abstract test suite specification".

### 3 Definitions and abbreviations

#### 3.1 Definitions

For the purposes of this ETS, the following definitions apply, in addition to those given in ETS 300 324-3 [1] and ETS 300 347-1 [2]:

**incorrect information element:** A specified information element carrying information element types which are not defined in ETS 300 347-1 [2].

**specified information element:** Information element identifier as defined in ETS 300 347-1 [2].

**unspecified information element:** Information element identifier which is not defined in ETS 300 347-1 [2].

#### 3.2 Abbreviations

For the purposes of this ETS, the following abbreviations apply:

AIS	Alarm Indication Signal
AN	Access Network
ANI	Access Network Interface
ASP	Abstract Service Primitive
ATS	Abstract Test Suite
BCC	Bearer Channel Connection
BI	Invalid Behaviour
BO	Inopportune Behaviour
BV	Valid Behaviour
CA	Capability
COM	Common control protocol
CTRL	Control
FE	Function Element
FSM	Finite State Machine
ID	Identifier
IE	Information Element
ISDN	Integrated Services Digital Network
ISDN-BA	ISDN Basic Access
ISDN-PRA	ISDN Primary Rate Access
IT	Basic Interconnection
IUT	Implementation Under Test
L3addr	Layer 3 address
LE	Local Exchange
LT1	Lower Tester 1
MDU	Management Data Unit
MPH	Management Physical layer
NWK	Network layer
PDU	Protocol Data Unit
PICS	Protocol Implementation Conformance Statement
PSTN	Public Switched Telephone Network
RAI	Remote Alarm Indication
REQ	Request
SN	Sequence Number
SUT	System Under Test
TE	Terminal Equipment (ISDN or PSTN)
TI	Timer
TP	Test Purpose
TS	Time Slot
TSS	Test Suite Structure
UP	User Port

## 4 Test Suite Structure (TSS)

### 4.1 Overview

Figure 1 shows the structure of the V5.2 network layer test suite.

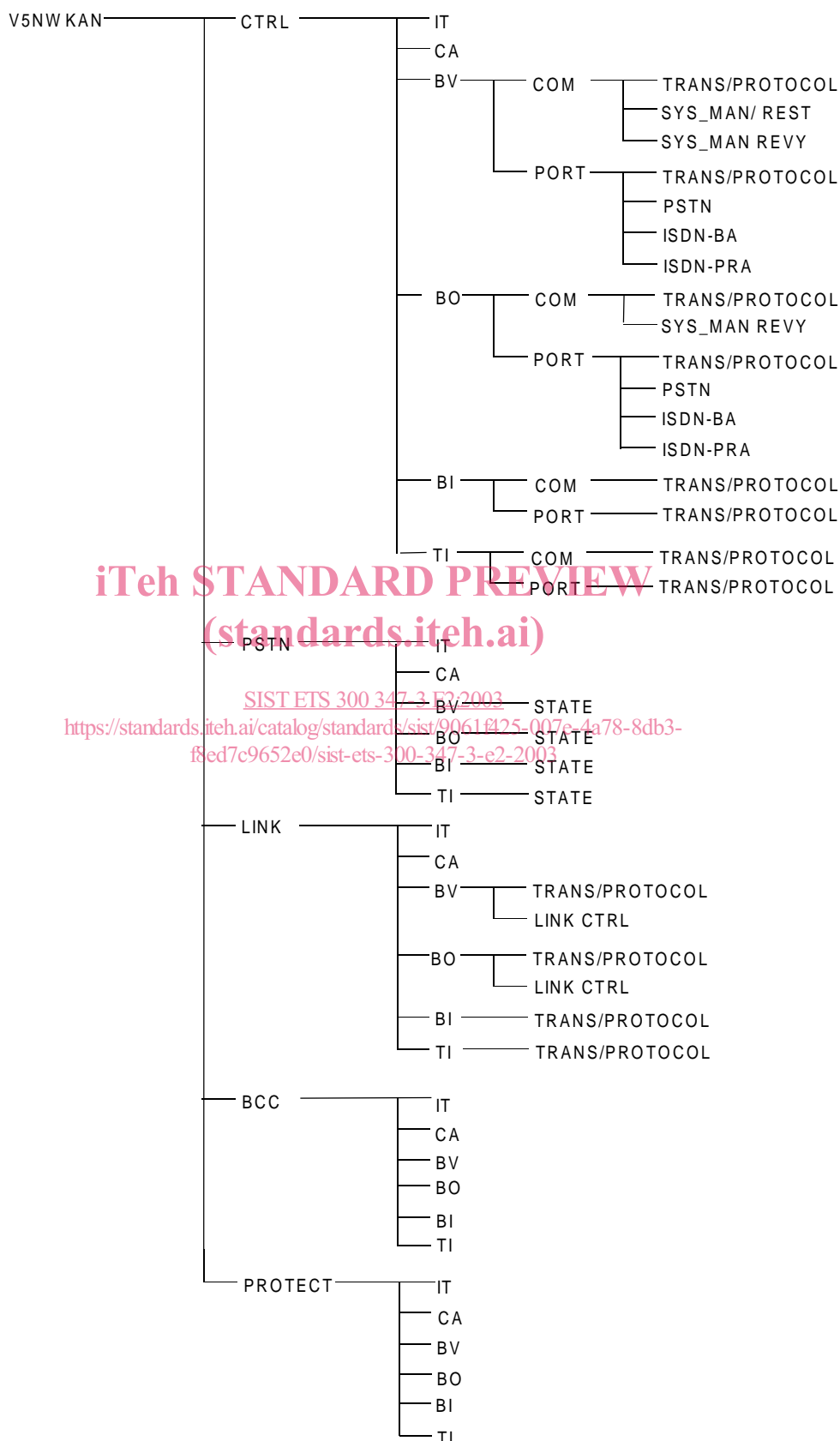

Figure 1: Network Layer AN test suite structure

4.2 Test groups

Figure 2 gives an overview of the various protocol entities of a V5.2 interface. Table 1 maps each protocol entity on tested protocol groups.

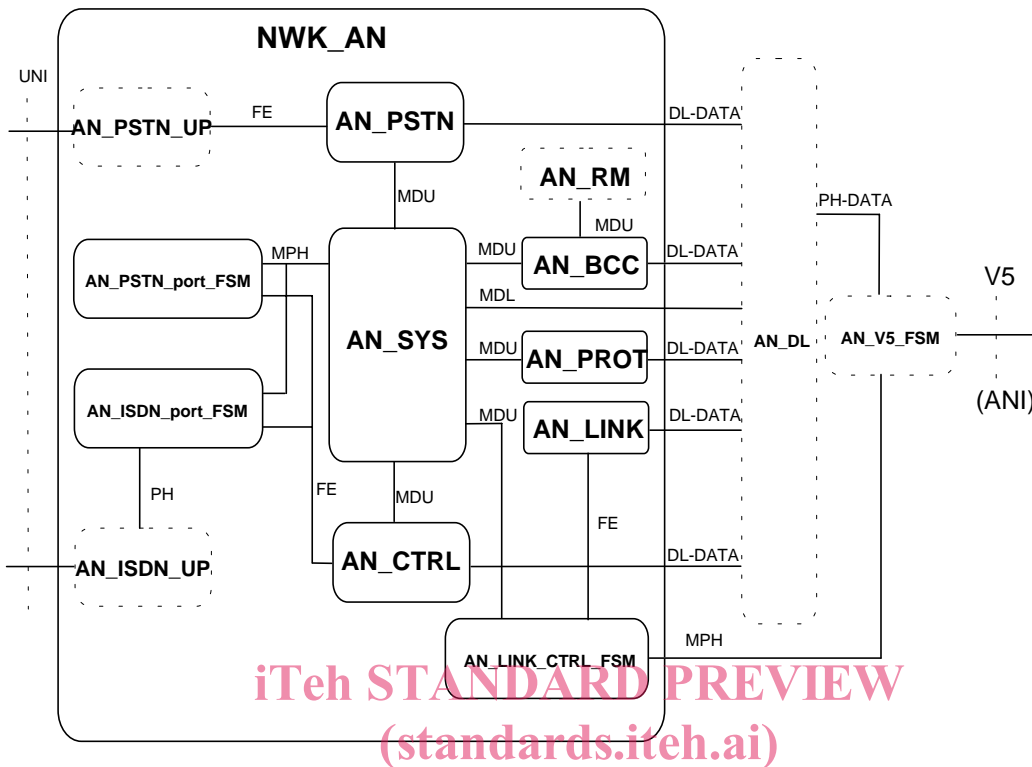

Figure 2: Network layer AN - protocol entity overview

SIST ETS 300 347-3 E2:2003

Table 1: Names used in figure 2 that correspond to ETS 300 347-1 [2]

f8ed7c9652e0/sist-ets-300-347-3-e2-2003

Network layer protocol entity	Protocol entity defined in ETS 300 347-1 [2]	Protocol group reference
AN_PSTN_UP	AN_PSTN_user_port	4.2.1.1
AN_PSTN_port_FSM	AN_PSTN_user_port_FSM	4.2.1.1
AN_ISDN_port_FSM	AN_ISDN_BA_user_port_FSM AN_ISDN_PRA_user_port_FSM	4.2.1.1
AN_ISDN_UP	AN_ISDN_BA_user_port AN_ISDN_PRA_user_port	4.2.1.1
AN_CTRL	AN_control_protocol	4.2.1.1
AN_SYS	AN_system_management	4.2.1.1
AN_PSTN	AN_PSTN_protocol	4.2.1.2
AN_LINK	AN_link_control_protocol	4.2.1.3
AN_LINK_CTRL_FSM	AN_link_control_FSM	4.2.1.3
AN_RM	AN_resource_manager	4.2.1.4
AN_BCC	AN_BCC_protocol	4.2.1.4
AN_PROT	AN_protection_protocol	4.2.1.5

## 4.2.1 Protocol groups

### 4.2.1.1 Control protocol

The contents of this subclause are identical to subclause 4.2.1.1 of ETS 300 324-3 [1] with the following additions for the ISDN-PRA user port Finite State Machine (FSM).

Depending on provisioning the following configuration is tested:

**AN\_ISDN-PRA\_user\_port:** The blocking, blocking request and co-ordinated unblocking procedures of the AN\_ISDN-PRA\_user\_port\_FSM are verified in the test group V5NWKAN/CTRL/BV/PORT/ISDNPRA and V5NWKAN/CTRL/BO/PORT/ISDNPRA.

### 4.2.1.2 Public Switched Telephone Network (PSTN) protocol

The contents of this subclause are identical to subclause 4.2.1.2 of ETS 300 324-3 [1].

### 4.2.1.3 Link control protocol

All tests in the Link control protocol (V5NWKAN/LINK) test group are intended to verify as thoroughly as possible the various procedures of the AN\_link\_control\_protocol entity.

Depending on provisioning the following configurations are covered:

**AN\_link\_control\_protocol:** The normal and exceptional procedures of the AN\_link\_control\_protocol are verified in the test groups V5NWKAN/LINK/BV/TRANS, V5NWKAN/LINK/BO/TRANS and V5NWKAN/LINK/TI/TRANS.

The error handling procedures are verified in the test group V5NWKAN/LINK/BI/TRANS.

**AN\_link\_control\_FSM:** The link blocking, link blocking request, co-ordinated link unblocking and link identification procedures of the AN\_link\_control\_FSM are verified in the test groups V5NWKAN/LINK/BV/LINK and V5NWKAN/LINK/BO/LINK.

### 4.2.1.4 Bearer Channel Connection (BCC) protocol

All tests in the BCC protocol (V5NWKAN/BCC) test group are intended to verify as thoroughly as possible the various procedures of the AN\_BCC protocol entity.

The following BCC procedures are covered:

- normal and exceptional bearer channel allocation procedure;
- normal and exceptional bearer channel de-allocation procedure;
- audit procedure;
- AN internal failure notification procedure;
- error handling procedures.

### 4.2.1.5 Protection protocol

All tests in the Protection protocol (V5NWKAN/PROTECT) test group are intended to verify as thoroughly as possible the various procedures of the AN Protection protocol entity.

The following Protection protocol procedures are covered:

- transmission of Protection protocol messages;
- normal and exceptional sequence number reset procedure;
- normal and exceptional standard protection switch-over procedure initiated by AN side;
- normal and exceptional dedicated protection switch-over procedure initiated by OS AN;
- normal and exceptional switch-over procedure requested by AN side;
- error handling procedures.