



Designation: C 645 – 06

## Standard Specification for Nonstructural Steel Framing Members<sup>1</sup>

This standard is issued under the fixed designation C 645; the number immediately following the designation indicates the year of original adoption or, in the case of revision, the year of last revision. A number in parentheses indicates the year of last approval. A superscript epsilon ( $\epsilon$ ) indicates an editorial change since the last revision or reapproval.

*This standard has been approved for use by agencies of the Department of Defense.*

### 1. Scope\*

1.1 This specification covers nonstructural steel framing members in interior construction assemblies.

1.2 The values stated in inch-pound units are to be regarded as the standard. The SI (metric) values given in parentheses are provided for information purposes only.

1.3 The following safety hazards caveat pertains only to the test methods portion, Sections 9 and 10, of this specification: *This standard does not purport to address all of the safety concerns, if any, associated with its use. It is the responsibility of the user of this standard to establish appropriate safety and health practices and determine the applicability of regulatory limitations prior to use.*

### 2. Referenced Documents

#### 2.1 ASTM Standards:<sup>2</sup>

**A 653/A 653M** Specification for Steel Sheet, Zinc-Coated (Galvanized) or Zinc-Iron Alloy-Coated (Galvannealed) by the Hot-Dip Process

**A 1003/A 1003M** Specification for Steel Sheet, Carbon, Metallic- and Nonmetallic-Coated for Cold-Formed Framing Members

**C 11** Terminology Relating to Gypsum and Related Building Materials and Systems

**C 36/C 36M** Specification for Gypsum Wallboard<sup>3</sup>

**C 1002** Specification for Steel Self-Piercing Tapping Screws for the Application of Gypsum Panel Products or Metal Plaster Bases to Wood Studs or Steel Studs

#### 2.2 AISI Standard:

**Specification for the Design of Cold-Formed Steel Structural Members**<sup>4</sup>

<sup>1</sup> This specification is under the jurisdiction of ASTM Committee C11 on Gypsum and Related Building Materials and Systems and is the direct responsibility of Subcommittee C11.02 on Specifications and Test Methods for Accessories and Related Products.

Current edition approved June 1, 2006. Published June 2006. Originally approved in 1970. Last previous edition approved in 2004 as C 645 – 04a.

<sup>2</sup> For referenced ASTM standards, visit the ASTM website, www.astm.org, or contact ASTM Customer Service at service@astm.org. For *Annual Book of ASTM Standards* volume information, refer to the standard's Document Summary page on the ASTM website.

<sup>3</sup> Withdrawn.

<sup>4</sup> Available from the American Iron and Steel Institute, 1000 16th St. N.W., Washington, DC 20036.

### 3. Terminology

3.1 **Definitions**—Definitions shall be in accordance with Terminology **C 11**.

#### 3.2 Definitions of Terms Specific to This Standard:

3.2.1 **members, n**—in screw application of gypsum board, studs, runners (track), hat furring channels, main beams and cross furring members of grid suspension systems or other items manufactured in accordance with this specification.

3.2.2 **nonstructural wall stud, n**—a member in a steel framed wall system which is limited to a lateral (transverse) load of not more than 10 lb/ft<sup>2</sup> (480 Pa), a superimposed vertical load, exclusive of sheathing materials, of not more than 100 lbf/ft (1460 N/m), or a superimposed vertical load of not more than 200 lbs (890 N).

### 4. Materials and Manufacture

4.1 Members shall be manufactured from steel meeting the requirements of Specification **A 1003/A 1003M**.

4.2 Members shall have a protective coating conforming to Specification **A 653/A 653M** – G 40 minimum or shall have a protective coating with an equivalent corrosion resistance.

4.3 Members shall be manufactured from steel having a minimum thickness, individual measurement of 0.0179 in. (0.455 mm) before application of protective coating.

### 5. Dimensions and Permissible Variations

5.1 Studs and rigid furring channels shall have a configuration and steel thickness such that the system in which they are used will carry the design transverse loads without exceeding either the allowable stress of the steel or the allowable design deflection. Main beams and cross furring of grid suspension systems shall be limited to a deflection of  $L/240$ . The manufacturer shall supply sufficient data for calculating design performance.

NOTE 1—Allowable deflection varies depending on the cladding used and architectural requirements. Detailed requirements shall be specified in application specifications.

5.1.1 Members, except main beams of grid suspension systems, shall be sufficiently rigid to permit penetration of the screw.

5.1.2 Minimum width of face to which gypsum board is screw-attached shall be not less than 1/4 in. (32 mm).

\*A Summary of Changes section appears at the end of this standard.

5.1.3 Minimum lip dimension shall be  $\frac{3}{16}$  in. (5 mm). See Fig. 1.

5.2 Members shall be manufactured within the limits as shown in Table 1 and Fig. 2.

5.3 Rigid Furring Channels—Minimum depth shall be  $\frac{7}{8}$  in. (22 mm). Minimum width of furring attachment flanges (see Fig. 3) shall be  $\frac{1}{2}$  in. (12.7 mm).

5.4 Grid suspension systems include main beams and cross furring members which mechanically interlock to form a modular supporting network. Length tolerance for grid suspension members shall be  $\pm \frac{1}{16}$  in. (1.59 mm).

5.5 Runners (track) shall be formed in a U-shaped configuration, having web depth compatible with those of the studs of the same nominal size. The runners (track) shall be designed such that when the studs are placed in both the top and bottom runners (track), they are held by friction. Minimum height of flanges shall be 1 in. (25 mm).

6. Edges

6.1 Members shall be manufactured in such a fashion as to minimize burrs and sharp edges.

TABLE 1 Manufacturing Tolerances

Dimension <sup>A</sup>	Item Checked	Drywall Studs, in. (mm)	Drywall Track, in. (mm)
A	length	+ $\frac{1}{8}$ (3.18)	+ 1 (25.40)
		- $\frac{1}{4}$ (6.35)	- $\frac{1}{4}$ (6.35)
B <sup>B</sup>	web width	+ $\frac{1}{32}$ (0.79)	+ $\frac{1}{8}$ (3.18)
		- $\frac{1}{32}$ (0.79)	- 0 (0)
C	flare overbend	+ $\frac{1}{16}$ (1.59)	+ 0 (0)
		- $\frac{1}{16}$ (1.59)	- $\frac{3}{16}$ (4.76)
D	hole center width	+ $\frac{1}{8}$ (3.18)	NA
		- $\frac{1}{8}$ (3.18)	
E	hole center length	+ $\frac{1}{4}$ (6.35)	NA
		- $\frac{1}{4}$ (6.35)	
F	crown	+ $\frac{1}{8}$ (3.18)	+ $\frac{1}{8}$ (3.18)
		- $\frac{1}{8}$ (3.18)	- $\frac{1}{8}$ (3.18)
G	camber	$\frac{1}{32}$ per ft (0.79)	$\frac{1}{32}$ per ft (0.79)
		$\frac{1}{2}$ max (12.7)	$\frac{1}{2}$ max (12.7)
H	bow	$\frac{1}{32}$ per ft (0.79)	$\frac{1}{32}$ per ft (0.79)
		$\frac{1}{2}$ max (12.7)	$\frac{1}{2}$ max (12.7)
I	twist	$\frac{1}{32}$ per ft (0.79)	$\frac{1}{32}$ per ft (0.79)
		$\frac{1}{2}$ max (12.7)	$\frac{1}{2}$ max (12.7)

<sup>A</sup> All measurements shall be taken not less than 1 ft (305 mm) from the end.  
<sup>B</sup> Outside dimension for stud; inside for track.

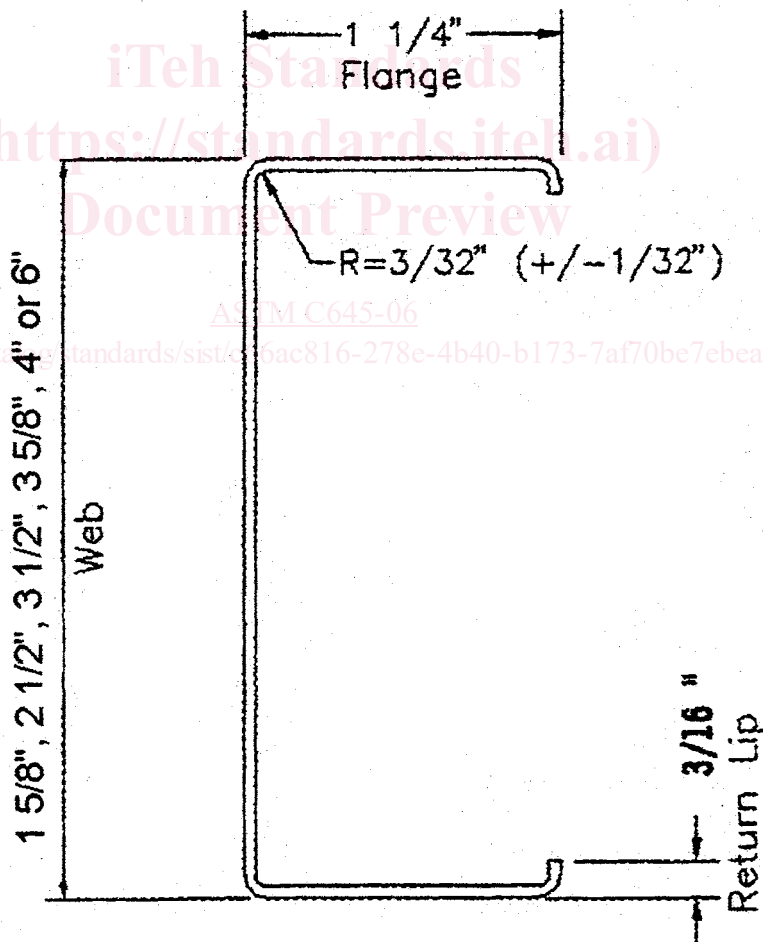

FIG. 1 Minimum Drywall Stud Cross Section

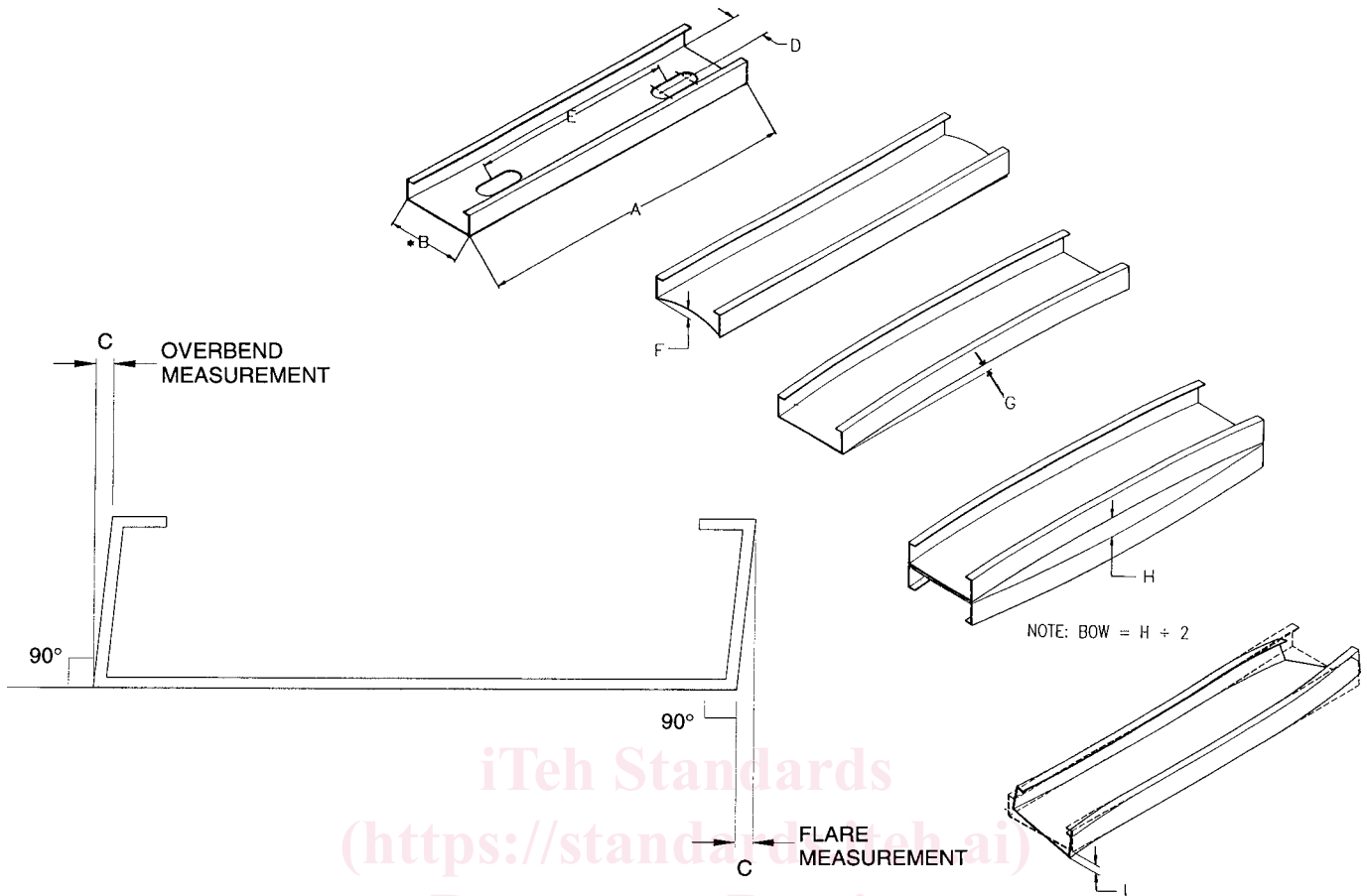

FIG. 2 Manufacturing Tolerances

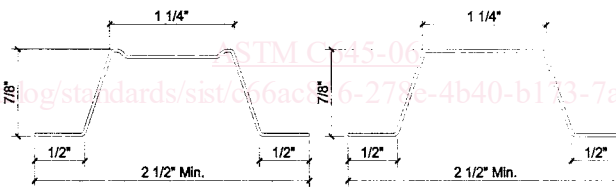

FIG. 3 Hat Furring Channel Cross Section

## 7. Cutouts

7.1 Cutouts shall not reduce the performance of the members in the gypsum board construction assembly below the specified performance requirements.

## 8. Sectional Properties

8.1 The sectional properties of members shall be computed in accordance with AISI Specifications for the Design of Cold-Formed Steel Structural Members (See Tables 2 and 3 and Figs. 1 and 3).

## 9. Performance Requirements

9.1 *Penetration*—When tested in accordance with Section 10, members shall be capable of pulling the head of the screw below the surface of the gypsum board in less than 2 s without spin out.

## 10. Penetration Test

10.1 *Significance and Use*—This test method provides a procedure for evaluating the member's ability to pull the head of a screw below the surface of gypsum board. It shall be used to determine compliance with this specification. The degree of performance of this test method with service performance has not been determined.

10.2 *Apparatus shall satisfy the following:*

10.2.1 *Electric Drill*, capable of 2500 r/min (free spindle speed), supplied with a screw driving bit to fit the screw used in the test.

10.2.2 *Stop Watch*, capable of being read to the nearest 0.1 s.

10.3 *Materials shall satisfy the following:*

10.3.1 *Wallboard*—Specification C 36, Type X, 5/8 in. (16 mm) thick.