



Designation: D4891 – 89 (Reapproved 2006)

Standard Test Method for Heating Value of Gases in Natural Gas Range by Stoichiometric Combustion¹

This standard is issued under the fixed designation D4891; the number immediately following the designation indicates the year of original adoption or, in the case of revision, the year of last revision. A number in parentheses indicates the year of last reapproval. A superscript epsilon (ϵ) indicates an editorial change since the last revision or reapproval.

1. Scope

1.1 This test method covers the determination of the heating value of natural gases and similar gaseous mixtures within the range of composition shown in **Table 1**.

1.2 *This standard involves combustible gases. It is not the purpose of this standard to address the safety concerns, if any, associated with their use. It is the responsibility of the user of this standard to establish appropriate safety and health practices and determine the applicability of regulatory limitations prior to use.*

2. Referenced Documents

2.1 *ASTM Standards:*²

D1826 Test Method for Calorific (Heating) Value of Gases in Natural Gas Range by Continuous Recording Calorimeter
E691 Practice for Conducting an Interlaboratory Study to Determine the Precision of a Test Method

3. Terminology

3.1 All of the terms defined in Test Method **D1826** are included by reference.

3.2 *Definitions of Terms Specific to This Standard:*

3.2.1 *combustion ratio*—the ratio of combustion air to gaseous fuel.

3.2.2 *stoichiometric ratio*—the combustion ratio when the quantity of combustion air is just sufficient to convert all of the combustibles in the fuel to water and carbon dioxide.

3.2.3 *burned gas parameter*—a property of the burned gas after combustion which is a function of the combustion ratio.

¹ This test method is under the jurisdiction of ASTM Committee **D03** on Gaseous Fuels and is the direct responsibility of Subcommittee **D03.03** on Determination of Heating Value and Relative Density of Gaseous Fuels.

Current edition approved June 1, 2006. Published June 2006. Originally approved in 1989. Last previous edition approved in 2001 as D4891–89 (2001). DOI: 10.1520/D4891-89R06.

² For referenced ASTM standards, visit the ASTM website, www.astm.org, or contact ASTM Customer Service at service@astm.org. For *Annual Book of ASTM Standards* volume information, refer to the standard's Document Summary page on the ASTM website.

3.2.4 *critical combustion ratio*—for a specific burned gas parameter, the combustion ratio at which a plot of burned gas parameter versus combustion ratio has either maximum value or maximum slope.

4. Summary of Test Method

4.1 Air is mixed with the gaseous fuel to be tested. The mixture is burned and the air-fuel ratio is adjusted so that essentially a stoichiometric proportion of air is present. More exactly, the adjustment is made so that the air-fuel ratio is in a constant proportion to the stoichiometric ratio which is a relative measure of the heating value. To set this ratio, a characteristic property of the burned gas is measured, such as temperature or oxygen concentration.

5. Significance and Use

5.1 This test method provides an accurate and reliable procedure to measure the total heating value of a fuel gas, on a continuous basis, which is used for regulatory compliance, custody transfer, and process control.

5.2 Some instruments which conform to the requirements set forth in this test method can have response times on the order of 1 min or less and can be used for on-line measurement and control.

5.3 The method is sensitive to the presence of oxygen and nonparaffin fuels. For components not listed and composition ranges that fall outside those in **Table 1**, modifications in the method may be required to obtain correct results.

6. Apparatus

6.1 A suitable apparatus for carrying out the stoichiometric combustion method will have at least the following four components: flow meter or regulator, or both; combustion chamber; burned gas sensor; and electronics. The requirement for each of these components is discussed below. The detailed design of each of these components can vary. Two different apparatus are shown in **Fig. 1** and **Fig. 2**. In each figure the equivalent of the four necessary components are enclosed in dashed lines.

6.2 *Overview*—Air and fuel enter the apparatus and the flow of each is measured. Alternatively, only one gas flow need be

TABLE 1 Natural Gas Components and Range of Composition Covered

Compound	Concentration Range, mole, %
Helium	0.01 to 5
Nitrogen	0.01 to 20
Carbon dioxide	0.01 to 10
Methane	50 to 100
Ethane	0.01 to 20
Propane	0.01 to 20
<i>n</i> -butane	0.01 to 10
isobutane	0.01 to 10
<i>n</i> -pentane	0.01 to 2
Isopentane	0.01 to 2
Hexanes and heavier	0.01 to 2

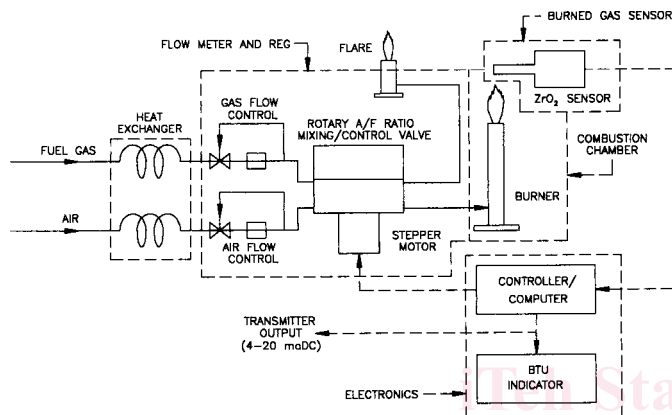

FIG. 1 Gas Btu Transmitter (Functional Overview)

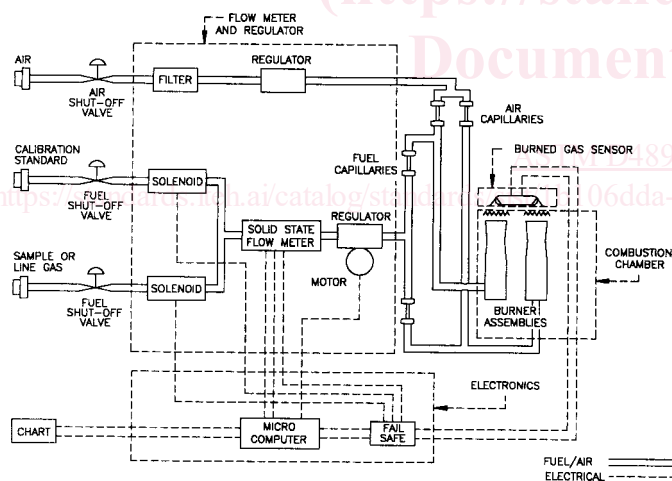

FIG. 2 Stoichiometric Combustion Apparatus

measured if the flow of the other is kept the same during measurement and calibration. This is illustrated in Fig. 2. Next there is a combustion chamber in which the air and fuel are mixed and burned. This can be as simple as a bunsen or meeker burner, but precautions should be taken that subsequent measurements of burned gas characteristics are not influenced by ambient conditions. Finally, there is a sensor in the burned gas which measures a property of this gas that is sensitive to the combustion ratio and has a unique feature at the stoichiometric ratio. Two such properties are temperature and oxygen concentrations, and either can be measured.

6.3 *Flow Meter and/or Regulator*—The flow measurement part of the apparatus should have an accuracy and precision of the order of 0.1 %. Likewise, if the flow is to be kept constant, the flow regulator should maintain this constant value within 0.1 %. The meter or regulator for natural gas must maintain this precision and accuracy over the density and viscosity ranges consistent with the composition range in Table 1.

6.4 *Combustion Chamber:*

6.4.1 There are two different types of combustion chambers that may be used. In the first type the air and fuel are mixed and burned in a single burner. The apparatus shown in Fig. 1 has this type of combustion chamber.

6.4.2 In the second type of combustion chamber, the air and fuel are each divided into two streams, and combustion takes place simultaneously in two burners. The division of air flow must be such that the proportion of air going to each burner always remains the same. Likewise the division of fuel flow must always remain the same even through fuel composition changes. Another requirement is that the flow divisions be such that one burner has a mixture with a slightly higher combustion ratio than the other. The apparatus shown in Fig. 2 has this type of combustion chamber.

6.5 *Burned Gas Sensor:*

6.5.1 The burned gas sensor must measure a characteristic of the burned gas which is a function of the combustion ratio and for which there is a critical combustion ratio related to the stoichiometric ratio. A combustion chamber of the first type (Fig. 1) would have one sensor in the burned gas and its output signal would constitute the desired measurement. In a combustion chamber of the second type (Fig. 2) there would be a sensor in the burned gas from each burner. The difference between the two output signals would constitute the desired measurement.

6.5.2 There are several properties of the burned gas which are related uniquely to the combustion ratio. A burned gas sensor may be selected which provides a measure of any one of these, for example, either temperature or oxygen partial pressure.

6.6 *Electronics*—Electronics are used to receive the signals from the components described above to control the flow of gases into the combustion chamber in response to the signal from the burned gas sensor and to provide a digital or analog output signal, or both, which is proportional to the heating value of the gaseous fuel.

6.7 *Temperature Stability and Operating Environment*—The method is capable of operating over a range of temperatures limited only by the specific apparatus used to realize the method. It is desirable to equilibrate the air and fuel temperatures before the gases are measured. The electronics should also be stabilized against temperature changes and the burned gas sensor should be insensitive to changes in the ambient conditions.

7. *Reagents and Materials*

7.1 *Physical Contamination*—The air and gas must be free of dust, liquid, water, liquid hydrocarbons, and other entrained solids. Foreign materials should be removed by a sample line