



Designation: D 3609 – 00

Standard Practice for Calibration Techniques Using Permeation Tubes¹

This standard is issued under the fixed designation D 3609; the number immediately following the designation indicates the year of original adoption or, in the case of revision, the year of last revision. A number in parentheses indicates the year of last approval. A superscript epsilon (ϵ) indicates an editorial change since the last revision or reapproval.

1. Scope

1.1 This practice describes a means for using permeation tubes for dynamically calibrating instruments, analyzers, and analytical procedures used in measuring concentrations of gases or vapors in atmospheres (1,2).²

1.2 Typical materials that may be sealed in permeation tubes include: sulfur dioxide, nitrogen dioxide, hydrogen sulfide, chlorine, ammonia, propane, and butane (1).

1.3 The values stated in SI units are to be regarded as the standard.

1.4 *This standard does not purport to address all of the safety concerns, if any, associated with its use. It is the responsibility of the user of this standard to establish appropriate safety and health practices and determine the applicability of regulatory limitations prior to use.*

2. Referenced Documents

2.1 ASTM Standards:

D 1356 Terminology Relating to Sampling and Analysis of Atmospheres³

D 3195 Practice for Rotameter Calibration³

E 1 Specification for ASTM Thermometers⁴

3. Terminology

3.1 *Definitions*—For definitions of terms used in this method, refer to Terminology D 1356.

4. Summary of Practice

4.1 A liquefiable gas, when enclosed in an inert plastic tube, escapes by permeating the tubing wall at a constant, reproducible, temperature-dependent rate.

4.2 Permeation tubes are calibrated gravimetrically, with the weight loss of the tube equated to the weight of the escaping material.

4.3 Permeation tubes are held at constant temperature in a carrier-gas stream of dry air or nitrogen to produce a gas concentration dependent on the permeation rate and the flow of the carrier gas.

5. Significance and Use

5.1 Most analytical methods used in air pollutant measurements are comparative in nature and require calibration or standardization, or both, often with known blends of the gas of interest. Since many of the important air pollutants are reactive and unstable, it is difficult to store them as standard mixtures of known concentration for extended calibration purposes. An alternative is to prepare dynamically standard blends as required. This procedure is simplified if a constant source of the gas of interest can be provided. Permeation tubes provide this constant source, if properly calibrated and if maintained at constant temperature. Permeation tubes have been specified as reference calibration sources, for certain analytical procedures, by the Environmental Protection Agency (3).

6. Interferences and Precautions

6.1 Permeation tubes are essentially devices to provide a constant rate of emission of a specific gaseous substance over period of time. They consist of a two-phase (gas-liquid) system to maintain a constant vapor pressure (at constant temperature) which is the driving force for emission of the gas through a semipermeable membrane (tube walls). They can be expected to maintain a constant emission rate that is temperature dependent as long as a significant amount of liquid is present in the device. The liquid shall be pure, else its composition may change during the life time of the tube, due to differential evaporation, with consequent vapor pressure changes. Care must also be exercised that the diffusion membrane (tube walls) is not damaged or altered during use. The contents of permeation tubes are under relatively high pressure. Accordingly, there is the possibility of violent rupture of tube walls under high temperature exposure. Permeation rates have temperature coefficients up to 10 % per degree Celsius. When temperature coefficients are large, above 3 % per degree Celsius, stringent temperature control is required. Furthermore permeation tubes exhibit temperature hysteresis so that they must be temperature equilibrated from 2 to 24 h before use, depending upon the temperature differential between storage

¹ This practice is under the jurisdiction of ASTM Committee D22 on Sampling and Analysis of Atmospheres and is the direct responsibility of Subcommittee D22.01 on Quality Control.

Current edition approved Sept. 10, 2000. Published November 2000. Originally published as D 3609 – 77. Last previous edition D 3609 – 96.

² The boldface numbers in parentheses refer to references appended to this standard.

³ *Annual Book of ASTM Standards*, Vol 11.03.

⁴ *Annual Book of ASTM Standards*, Vol 14.03.

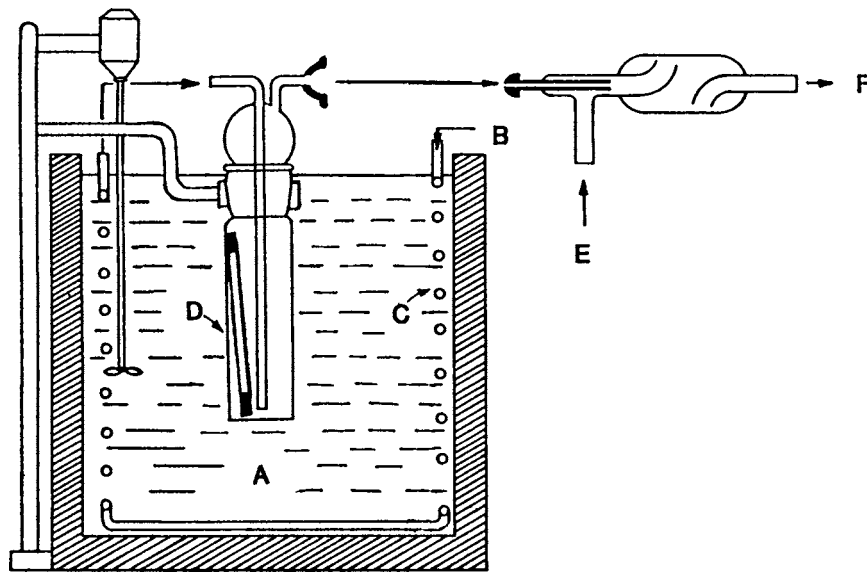

A—Thermostated water bath with thermometer
 B—Metered pure air inlet
 C—Air temperature equilibration coil
 D—Permeation tube
 E—Metered dilution air inlet
 F—Air mixture outlet

NOTE 1—This system has the advantage of smaller uncertainty of the temperature of the permeation tube.
FIG. 1 Optional System for Laboratory Use of a Permeation Tube

and use (4). It is important that permeation tubes are filled with anhydrous constituents of high purity. They shall be handled with care to minimize contact with moisture, oil, and foreign substances.

6.2 Sulfur dioxide (SO₂) permeation tubes are relatively insensitive to interferences.

6.3 Nitrogen dioxide (NO₂) permeation tubes are sensitive to moisture, hence they should be stored in dry atmospheres and used with relatively dry carrier gases (<10% relative humidity). Permeation of moisture into the contents of a tube may damage the walls and also cause progressive decreases in the permeation rate. Moisture incorporated in the contents during manufacture can cause the same effect (4).

6.4 Hydrogen sulfide (H₂S) permeation tubes may turn white during use in the presence of oxygen because of inverse permeation and formation of colloidal sulfur. This phenomenon may affect the permeation rate, if severe, hence is a reason for recalibration. However, in an inert gas stream, the tubes are relatively stable.

6.5 Materials of construction shall be compatible with the contents of the tube. For instance, some fluorocarbons may cause FEP tubes to swell and possibly to rupture.

7. Apparatus

7.1 *Permeation Tube* sized in accordance with and calibrated to concentrations needed or expected for the analysis method. The user should check calibration as described in Section 9.1.

7.2 *Flow and Temperature Control System*—Prepare or purchase a system that will dry the carrier gas, and control and measure its flow as it passes over the permeation tube that is

being held at constant temperature. If lower concentrations are desired, a second gas supply (diluent gas) with its control and measurement devices may be needed to mix with the gas from the permeation tube chamber. Equipment of this kind is available commercially. A typical system contains a thermoelectrically temperature-controlled permeation tube chamber with temperature control within ±0.1°C over the range from 15 to 35°C. Such equipment is well suited to field usage.

7.3 A typical system for laboratory use that can be assembled from readily available parts is shown schematically in Fig. 1. The parts required are described in the following subsections.

7.3.1 *Flowmeters*—Several, sufficient to cover the range from 0 to 15 L/min, calibrated by Practice D 3195.

7.3.2 *Copper Tubing*—Approximately 1 m long (3 ft) by 6.25 mm (0.25 in.) in outside diameter for use as a heat exchanger in the water bath.

7.3.3 *Ball Joints (Ungreased) and Tubing*, for the necessary connections. Butt seals may also be used made with inert materials such as polyethylene.

7.3.4 *Mixing Bulb*—to ensure adequate mixing of the permeated gas and the diluent gas stream. A Kjeldahl trap is recommended.

7.3.5 *Long Condenser*, with large bore in which a thermometer and a permeation tube can be inserted.

7.3.6 *Temperature Controlled Water Bath*—About 8-L (2-gal) capacity, capable of ±0.1°C or better water temperature control, with a variable temperature control range from about 15 to 35°C, preferably equipped with a positive displacement type recirculating pump with at least 1-L/min liquid flow rate to supply water to the condenser.