



Designation: F 2544 – 06

Standard Test Method for Determining A-Weighted Sound Power Level of Central Vacuum Power Units¹

This standard is issued under the fixed designation F 2544; the number immediately following the designation indicates the year of original adoption or, in the case of revision, the year of last revision. A number in parentheses indicates the year of last reapproval. A superscript epsilon (ϵ) indicates an editorial change since the last revision or reapproval.

1. Scope

1.1 This test method calculates the overall A-weighted sound power level emitted by central vacuum power units, intended for operation in domestic applications. This standard applies to the power unit only at the power unit location. To test the sound power level of a central vacuum at the user's location, refer to Test Method F 1334.

1.2 A-weighted sound pressure measurements are performed on a mounted central vacuum power unit in a semi-reverberant room. This test method determines sound power by a comparison method for small noise sources, that is, comparison to a broad band reference sound source.

1.3 This test method describes a procedure for determining the A-weighted sound power level of small noise sources. This test method uses a non-special semi-reverberant room.

1.4 Results are expressed as A-weighted sound power level in decibels.

1.5 The values stated in inch pound units are to be regarded as the standard. The values in parentheses are for information only.

1.6 *This standard does not purport to address all of the safety concerns, if any, associated with its use. It is the responsibility of the user of this standard to establish appropriate safety and health practices and determine the applicability of regulatory limitations prior to use.*

2. Referenced Documents

2.1 ASTM Standards:²

- C 634 Terminology Relating to Environmental Acoustics
- E 177 Practice for Use of the Terms Precision and Bias in ASTM Test Methods
- E 691 Practice for Conducting an Interlaboratory Study to Determine the Precision of a Test Method

¹ This test method is under the jurisdiction of ASTM Committee F11 on Vacuum Cleaners and is the direct responsibility of Subcommittee F11.25 on Sound Measurement.

Current edition approved July 1, 2006. Published July 2006.

² For referenced ASTM standards, visit the ASTM website, www.astm.org, or contact ASTM Customer Service at service@astm.org. For *Annual Book of ASTM Standards* volume information, refer to the standard's Document Summary page on the ASTM website.

F 820 Test Method for Measuring Air Performance Characteristics of Central Vacuum Cleaning Systems

F 1334 Test Method for Determining A-Weighted Sound Power Level of Vacuum Cleaners

2.2 ANSI Standards:³

S1.10 Method for the Calibration of Microphones

S1.26 Method for the Calculation of the Absorption of Sound by the Atmosphere

S1.43 Specifications for Sound Level Meters, IEC 804 and IEC 61672

S12.31 Precision Methods for the Determination of Sound Power Levels of Broad Band Noise Sources in Reverberant Rooms

S12.32 Precision Methods for Determination of Sound Power Levels for Discrete Frequency and Narrow Band Noise Sources in Reverberant Rooms

S12.33 Engineering Methods for Determination of Sound Power Levels of Noise Sources in a Special Reverberant Test Room

2.3 ISO Standards:³

ISO 3741, 3742, and 3743 are similar to and may be used in place of ANSI S12.31, S12.32, and S12.33 respectively

2.4 IEC Standard:³

60704.1 Test Code for the Determination of Airborne Acoustical Noise Emitted by Household and Similar Electrical Appliances

3. Terminology

3.1 Unless otherwise indicated, definitions are in accordance with Terminology C 634.

3.2 Definitions:

3.2.1 *population, n*—total of all of the units of the particular model or type, or both, of central vacuum power units being tested.

3.2.2 *population sample or sample, n*—three or more units, randomly taken from the population.

3.2.3 *reference sound source, n*—standard source of broadband sound with a certified set of sound power emissions.

³ Available from American National Standards Institute (ANSI), 25 W. 43rd St., 4th Floor, New York, NY 10036.

3.2.4 *source, n*—device that emits sound.

3.2.5 *test unit or units, n*—single central vacuum power unit of the model or type, or both, being tested.

4. Significance and Use

4.1 The test results enable the comparison of A-weighted sound emission from central vacuum power units when tested under the condition of this test method.

5. Test Room Requirements

5.1 The test room shall be semi-reverberant. It shall contain sufficiently little sound absorption material so the requirements of 5.2 can be met. It shall be large enough to allow a semi-circle with a 9-ft radius centered at the sound source (the central vacuum power unit) that shall be clear of all obstruction, including the operator, during the measurements.

5.1.1 The test room should be plumbed for the central vacuum according to the manufacturer’s instructions using standard 2-in. outside diameter thin-wall PVC tubing. Units with multiple exhaust ports shall be plumbed with multiple exhaust lines per manufacturer’s instructions. Units without exhaust ports shall not have an exhaust line plumbed outside the test room. The power unit is to be mounted on the wall per the manufacturer’s recommendations.

5.2 Three microphone positions are to be used. The microphone positions are to be on a semi-circle with a 9-ft radius centered at the sound source (the central vacuum power unit). The microphone positions will be spaced 30° from the wall and

60° apart from each other on the semi-circle at a height of 60 in. (1.5 m). The microphone should be oriented per the microphone manufacturer’s instructions. Refer to Fig. 1 for layout. These positions shall result in a standard deviation of the three sound pressure measurements of not more than 2.3 dB when measuring the reference sound source.

5.3 *Environmental*—Ambient test conditions within the test room shall be controlled to 70 ± 5°F (21 ± 3°C) and 30 to 70 % relative humidity.

5.4 Also, any room which has qualified in accordance with ANSI S1.26, S12.31, S12.32, S12.33, ISO 3741, 3742, and 3743 may be used to measure the sound power levels of vacuum cleaners.

5.5 The measured A-weighted sound pressure levels shall be corrected for the influence of background noise according to Table 1. When the steady background-noise sound pressure level is more than 6 dB below the sound pressure level at each measurement point, the measured A-weighted sound pressure levels shall be corrected for the influence of background noise. If this difference is less than 6 dB, no correction is allowed and any reported data must include a note indicating that the background noise requirements of this test method were not satisfied.

6. Instrumentation and Equipment

6.1 *Acoustical Instrumentation*—The sound measurement system shall be as specified in ANSI S1.43.

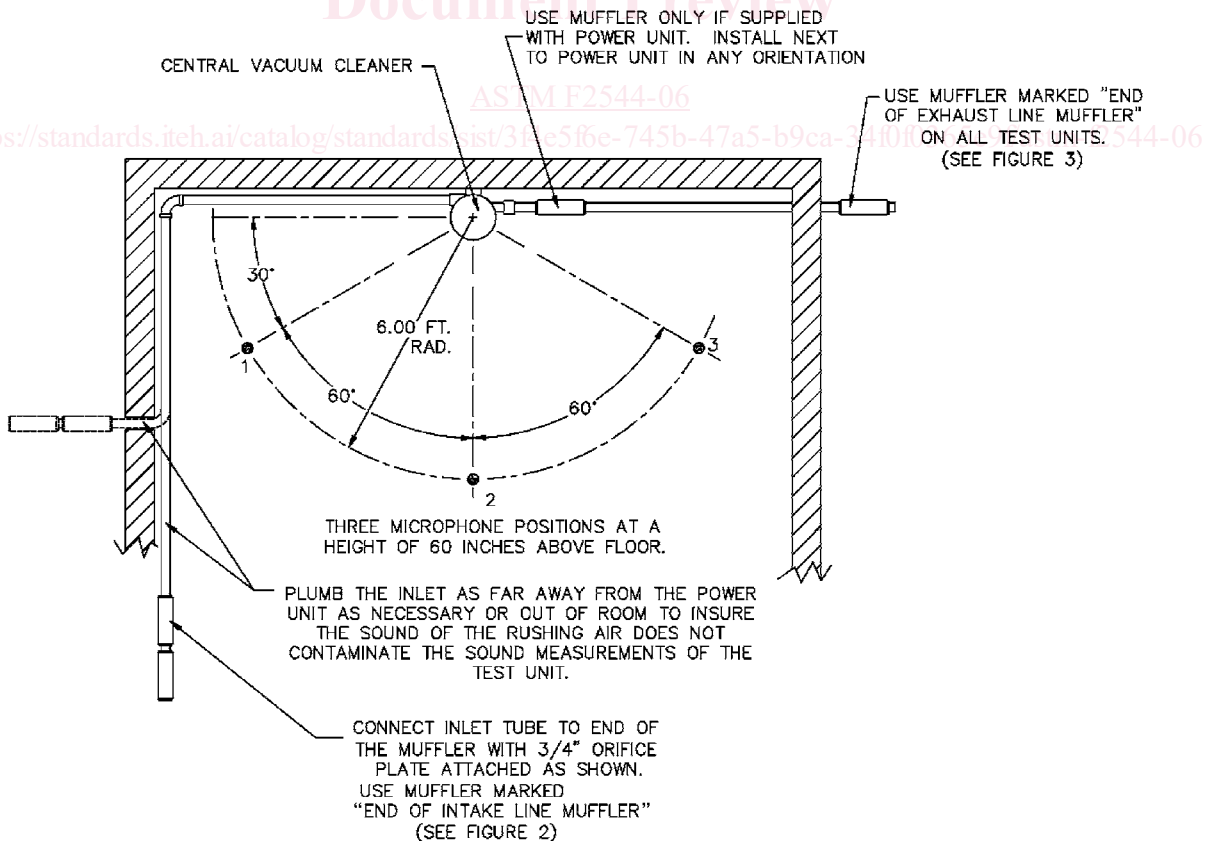

FIG. 1 Sound Test Layout

TABLE 1 Corrections for Background Noise Levels

Difference between sound pressure level measured with sound source operating and background noise level alone, dB	Correction to be subtracted from sound pressure level measured with sound source operating to obtain sound pressure level due to sound source alone, dB
Less than 6	No correction allowed
6	1
7	1
8	1
9	0.5
10	0.5
Greater than 10	0

6.2 *Voltage Regulator System*—The regulator shall be capable of maintaining the vacuum cleaner’s rated voltage ($\pm 1\%$) and frequency (± 1 Hz) having a waveform that is essentially sinusoidal with 3 % maximum harmonic distortion for the duration of the test.

6.3 *Reference Sound Source*—The reference sound source shall meet the requirements of Section 9 of ANSI S12.31.

6.4 *Instrumentation:*

6.4.1 *Thermometer*, accurate to $\pm 3^\circ\text{F}$ ($\pm 2^\circ\text{C}$).

6.4.2 A means of measuring relative humidity, accurate to within $\pm 2\%$ over the range used.

7. Operation of Central Vacuum Cleaner

7.1 *Run in*—Operate new test cleaners continuously for at least 10 min prior to testing. The central vacuum power unit should be run with the orifice adapter tube (as specified in Test Method F 820) connected to the power unit inlet (for run-in only).

7.2 *Warm up*—Operate the cleaners for 10 min just prior to making sound pressure level measurements in the same configuration as shown in Fig. 1.

7.3 *Test Configuration:*

7.3.1 The inlet tube and exhaust line should be plumbed with PVC tubing as far away from the test unit as necessary or out of the test room to prevent from contaminating the sound test. Refer to Fig. 1 for proper test set up of test unit, intake tube, and exhaust line.

7.3.2 A muffler should only be attached to the exhaust line beside the test unit if it is supplied with the test unit.

7.3.3 The “end of intake line muffler” is part of the standard test set-up and should be used on all test units. Its intent is to dampen any noise created by the air rushing into the inlet tube to prevent contamination of the sound measurements of the test unit. This muffler is equipped with a $\frac{3}{4}$ -in. sharp edge orifice plate (taking the place of the hose and floor tool).

7.3.4 The “end of exhaust line muffler” is part of the standard test set-up and should be used on all test units. Its intent is to dampen any noise created by the air rushing out of the exhaust tube to prevent contamination of the sound measurements of the test unit. This muffler does not include an orifice plate.

7.3.5 The dust bag or primary filter shall be new (if applicable).

7.3.6 *Voltage*—Tests are to be conducted at the nameplate rated voltage ($\pm 1\%$) and frequency (± 1 Hz) throughout the test. For cleaners with dual nameplate voltage ratings, conduct sound tests at the highest voltage.

8. Location of Sound Sources and Equipment

8.1 Locate the central vacuum power unit at the position determined in 5.1.1.

8.2 Locate the reference sound source on the floor (near but not touching) the wall, below the intended location of the vacuum power unit. The microphones should be placed on a 6-ft radius from the center of the vacuum power unit’s intended location while testing the reference sound source.

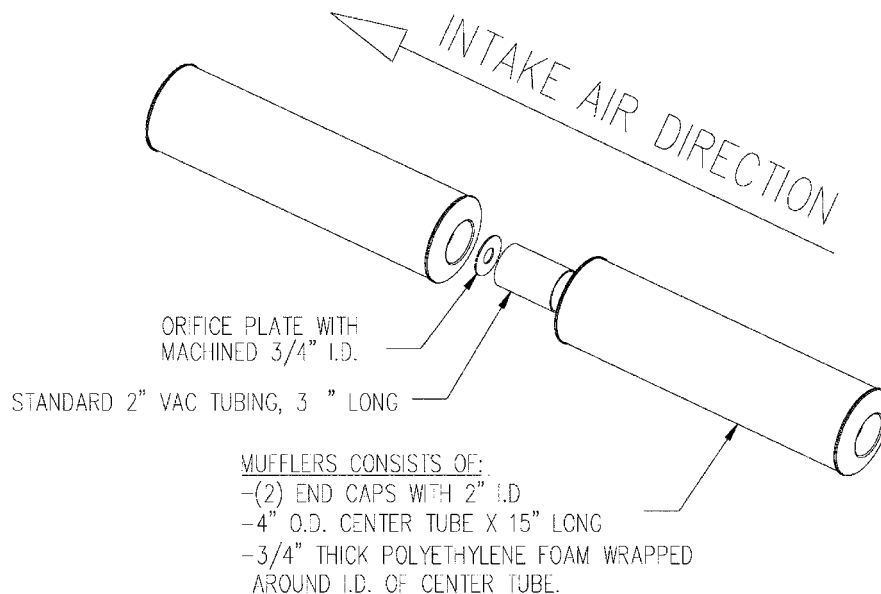
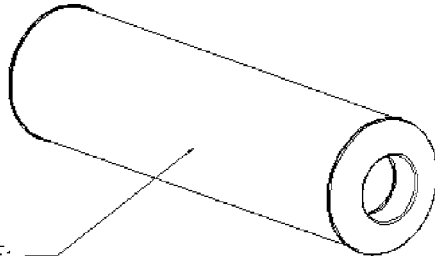

FIG. 2 End of Intake Line Muffler



MUFFLER CONSISTS OF:
 - (2) END CAPS WITH 2" I.D.
 - 4" O.D. CENTER TUBE X 15" LONG
 - 3/4" THICK POLYETHYLENE FOAM WRAPPED
 AROUND I.D. OF CENTER TUBE.

FIG. 3 Exhaust Line Muffler

9. Measurement Procedure

9.1 Check the calibration of each microphone according to the instrument manufacturer's directions.⁴

9.2 At each of the three microphone positions determined in 5.2, measure the background A-weighted sound pressure level. Step 9.2 can be ignored if it is known that the background sound pressure levels are more than 10 dB below the sound pressure levels of all sources being considered at all microphone locations.

9.3 With the reference sound source in the location defined in Section 8 and running in accordance with the manufacturer's recommendations, measure the A-weighted sound pressure level at the microphone positions (as described in 5.2). After making the necessary corrections for the influence of the background noise at each microphone location and ensuring that the standard deviation requirement of 5.2 is met, calculate the space-averaged A-weighted sound pressure level of the reference sound source, L_{pr} , using the equation:

$$L_p \text{ or } L_{pr} = 10 \log \left\{ \frac{1}{N_m} \sum_{i=1}^{N_m} 10^{L_i/10} \right\} \quad (1)$$

where:

L_p or L_{pr} = A-weighted sound pressure level averaged over all microphone positions for a single source location, dB,

L_i = A-weighted sound pressure level for the i th microphone position, dB, and

N_m = number of microphone positions.

9.4 Remove the reference sound source and mount the test unit per the manufacturer's recommendations. The microphones should be positioned as shown in Fig. 1. With the unit operating in accordance with Section 7, measure the A-weighted sound pressure level at the same microphone locations. After making the necessary corrections for the influence of the background noise at each microphone location, calculate the space-averaged A-weighted sound pressure level, L_p , of the test unit using the equation in 9.3.

9.5 Using the space-averaged A-weighted sound pressure levels, L_{pr} and L_p , and the known A-weighted sound power level of the reference sound source, calculate the A-weighted sound power level of the test unit using the procedure in 10.1.

9.6 Using the same test unit, repeat 9.2-9.5 two additional times for a total of three test runs.

9.7 The sound power level (score) for each individual test unit is the arithmetic average of the A-weighted sound power levels of three test runs that meet the repeatability requirements of Section 14. See Annex A1 for a procedural example and to determine if additional test runs need to be conducted.

9.8 A minimum of two additional test units of the same model must be selected in accordance with the sampling statement in Section 11. Repeat 9.2-9.7 for each additional test unit. See Annex A1 for a procedural example and to determine if additional units need to be tested.

9.9 The best estimate of A-weighted sound power level for the population of the central vacuum power unit model being tested is the arithmetic mean of A-weighted sound power level of the sample population meeting the requirements of the sampling statement in Section 11.

10. Calculation of A-weighted Sound Power Levels for the Comparison Method

10.1 The A-weighted sound power level produced by the test unit shall be calculated as follows. Subtract the A-weighted sound pressure level produced by the reference sound source (corrected for background noise according to 5.5) from the A-weighted sound pressure level of the test unit under test (corrected for the background noise according to 5.5). Add the difference to the known A-weighted sound power level produced by the reference sound source.

$$L_W = L_{wr} + L_p - L_{pr} \quad (2)$$

where:

L_W = the A-weighted sound power level, in decibels, produced by the test unit under test,

L_p = the average A-weighted sound pressure level, in decibels, produced by the test unit under test, as determined in accordance with 9.4,

L_{wr} = the known A-weighted sound power level, in decibels, produced by the reference sound source, and

L_{pr} = the average A-weighted sound pressure level, in decibels, produced by the reference sound source, as determined in accordance with 9.3.

11. Sampling

11.1 Test a sufficient number of samples of each power unit model until a 90 % confidence level is established within ± 2.0 dBA of the mean value. Test a minimum of three samples.

12. Information

12.1 *General*—Record the name and location of the test laboratory, including the date and time of the measurements.

12.2 *Test Room*—Record the description of the room construction, dimensions, configurations, and deployment of absorptive materials, etc.

12.3 *Equipment*—Maintain recorded diagram of the acoustical data acquisition system. This shall include the model number and serial number of all microphones, preamplifiers, filters, meters, etc. Describe microphone cables specifically. Record the calibrator model number and serial number, output

⁴ Further information is provided in ANSI S1.10.