



Designation: D4700 – 91(Reapproved 2006)

## Standard Guide for Soil Sampling from the Vadose Zone<sup>1</sup>

This standard is issued under the fixed designation D4700; the number immediately following the designation indicates the year of original adoption or, in the case of revision, the year of last revision. A number in parentheses indicates the year of last reapproval. A superscript epsilon ( $\epsilon$ ) indicates an editorial change since the last revision or reapproval.

### 1. Scope

1.1 This guide covers procedures that may be used for obtaining soil samples from the vadose zone (unsaturated zone). Samples can be collected for a variety of reasons including the following:

- 1.1.1 Stratigraphic description,
- 1.1.2 Hydraulic conductivity testing,
- 1.1.3 Moisture content measurement,
- 1.1.4 Moisture release curve construction,
- 1.1.5 Geotechnical testing,
- 1.1.6 Soil gas analyses,
- 1.1.7 Microorganism extraction, or
- 1.1.8 Pore liquid and soils chemical analyses.

1.2 This guide focuses on methods that provide soil samples for chemical analyses of the soil or contained liquids or contaminants. However, comments on how methods may be modified for other objectives are included.

1.3 This guide does not describe sampling methods for lithified deposits and rocks (for example, sandstone, shale, tuff, granite).

1.4 In general, it is prudent to perform all field work with at least two people present. This increases safety and facilitates efficient data collection.

1.5 The values stated in inch-pound units are to be regarded as standard. The values given in parentheses are mathematical conversions to SI units that are provided for information only and are not considered standard.

1.6 *This standard does not purport to address all of the safety concerns, if any, associated with its use. It is the responsibility of the user of this standard to establish appropriate safety and health practices and determine the applicability of regulatory limitations prior to use.*

1.7 *This guide offers an organized collection of information or a series of options and does not recommend a specific course of action. This document cannot replace education or experience and should be used in conjunction with professional*

*judgment. Not all aspects of this guide may be applicable in all circumstances. This ASTM standard is not intended to represent or replace the standard of care by which the adequacy of a given professional service must be judged, nor should this document be applied without consideration of a project's many unique aspects. The word "Standard" in the title of this document means only that the document has been approved through the ASTM consensus process.*

### 2. Referenced Documents

2.1 *ASTM Standards:*<sup>2</sup>

[D653 Terminology Relating to Soil, Rock, and Contained Fluids](#)

[D1452 Practice for Soil Exploration and Sampling by Auger Borings](#)

[D1586 Test Method for Penetration Test \(SPT\) and Split-Barrel Sampling of Soils](#)

[D1587 Practice for Thin-Walled Tube Sampling of Soils for Geotechnical Purposes](#)

[D2488 Practice for Description and Identification of Soils \(Visual-Manual Procedure\)](#)

[D3550 Practice for Thick Wall, Ring-Lined, Split Barrel, Drive Sampling of Soils](#)

[D4220 Practices for Preserving and Transporting Soil Samples](#)

### 3. Terminology

3.1 *Definitions:*

3.1.1 Except where noted, all terms and symbols in this guide are in accordance with the following publications. In order of consideration they are:

3.1.1.1 Terminology [D653](#).

3.1.1.2 *Compilation of ASTM Standard Terminology*,<sup>3</sup> and

3.1.1.3 *Webster's New Collegiate Dictionary*.<sup>4</sup>

3.1.2 For definitions and classifications of soil related terms used, refer to Practice [D2488](#) and Terminology [D653](#). Additional terms that require clarification are defined in [3.2](#).

<sup>1</sup> This guide is under the jurisdiction of ASTM Committee [D18](#) on Soil and Rock and is the direct responsibility of Subcommittee [D18.21](#) on Groundwater and Vadose Zone Investigations.

Current edition approved July 1, 2006. Published August 2006. Originally approved in 1991. Last previous edition approved in 1998 as D4700 – 91 (1998) <sup>$\epsilon$ 1</sup>. DOI: 10.1520/D4700-91R06.

<sup>2</sup> For referenced ASTM standards, visit the ASTM website, [www.astm.org](http://www.astm.org), or contact ASTM Customer Service at [service@astm.org](mailto:service@astm.org). For *Annual Book of ASTM Standards* volume information, refer to the standard's Document Summary page on the ASTM website.

<sup>3</sup> *Compilation of ASTM Standard Terminology*, Sixth edition, ASTM International, 100 Barr Harbor Drive, West Conshohocken, PA, 1986.

<sup>4</sup> *Webster's New Collegiate Dictionary*, Fifth edition, 1977.

Type of Sampler	Obtains Core Sample		Most Suitable Core Types Coh. Coh'less	Operation in Storey Soils Fav. Unfav.	Most Suitable Soil Moisture Conditions			Access to Sample Sites During Poor Soil Conditions		Relative Sample Size Sm. Lg.	Labor Req'mts Sngl. 2/More
	Yes	No			Wet	Dry	Inter.	Yes	No		
<b>A. Drill Rig Samplers</b>											
1. Multipurpose Drill Rig	♦										
2. Split-barrel Drive Sampler	♦										
3. Thin-Walled Tube Sampler	♦										
4. Piston Sampler	♦										
5. Continuous Sample Tube system	♦										
6. Hand-Held Power Auger		♦									
<b>B. Hand Operated Samplers</b>											
1. Screw-Type Auger		♦									
2. Barrel Auger											
a. Post-Hole Auger		♦	♦								
b. Dutch Auger		♦									
c. Regular Barrel Auger		♦									
d. Sand Auger		♦									
e. Mud Auger		♦									
3. Tube-Type Sampler											
a. Soil Sampling Tube											
(1) Wet Tip		♦									
(2) Dry Tip		♦									
b. Veilmeyer Tube		♦									

FIG. 1 Criteria for Selecting Soil Sampling Equipment

3.2 Definitions of Terms Specific to This Standard:

3.2.1 *cascading water*—perched ground water that enters a well casing via cracks or uncovered perforations, trickling, or pouring down the inside of the casing.

3.2.2 *sludge*—a water charged sedimentary deposit.

3.2.2.1 *Discussion*—The water-formed sedimentary deposit may include all suspended solids carried by the water and trace elements that were in solution in the water. Sludge usually does not cohere sufficiently to retain its physical shape when mechanical means are used to remove it from the surface on which it deposits, but it may be baked in place and be adherent.

4. Summary of Guide

4.1 Sampling vadose zone soil involves inserting into the ground a device that retains and recovers a sample. Devices and systems for vadose zone sampling are divided into two general groups, namely the following: samplers used in conjunction with hand operated devices; and samplers used in conjunction with multipurpose or auger drill rigs. This guide discusses these groups and their associated practices.

4.2 The discussion of each device is organized into three sections, describing the device, describing sampling methods, and limitations and advantages of its use.

4.3 This guide identifies and describes a number of sampling methods and samplers. It is advisable to consult available site-specific geological and hydrological data to assist in determining the sampling method and sampler best suited for a specific project. It is also advisable to contact a local firm providing the services required as not all sampling and drilling methods described in this guide are available nationwide.

5. Significance and Use

5.1 Chemical analyses of liquids, solids, and gases from the vadose zone can provide information on the presence, possible source, migration route, and physical-chemical behavior of contaminants. Remedial or mitigating measures can be formulated based on this information. This guide describes devices and procedures that can be used to obtain vadose zone soil samples.

5.2 Soil sampling is useful for the reasons presented in Section 1. However, it should be recognized that the general method is destructive, and that resampling at an exact location is not possible. Therefore, if a long term monitoring program is being designed, other methods for obtaining samples should be considered.

6. Criteria for Selecting Soil Samplers

6.1 Important criteria to consider when selecting devices for vadose zone soil sampling include the following:

6.1.1 Type of sample: An encased core sample, an uncased core sample, a depth-specific representative sample, or a sample according to requirements of the analyses,

6.1.2 Sample size requirements,

6.1.3 Suitability for sampling various soil types,

6.1.4 Maximum sampling depth,

6.1.5 Suitability for sampling soils under various moisture conditions,

6.1.6 Ability to minimize cross contamination,

6.1.7 Accessibility to the sampling site, and

6.1.8 Personnel requirements.

6.2 The sampling devices described in this guide have been evaluated for these criteria. The results are summarized in Fig. 1.

7. Sampling with Hand Operated Devices

7.1 These devices, that have mostly been developed for agricultural purposes, include:

7.1.1 Screw-type augers,

7.1.2 Barrel augers,

7.1.3 Tube-type samplers,

7.1.4 Hand held power augers, and

7.1.5 Trench sampling with shovels in conjunction with machine excavations.

7.2 The advantages of using hand operated devices over drill rigs are the ease of equipment transport to locations with poor vehicle access, and the lower costs of setup and decontamination. However, a major disadvantage is that these devices are limited to shallower depths than drill rigs.

7.3 *Screw-Type Augers:*

7.3.1 *Description*—The screw or ship auger is essentially a small diameter (for example, 1.5 in. (3.81 cm)) wood auger from which the cutting side flanges and tip have been removed (1)<sup>5</sup> (see Fig. 2(a)). According to the Soil Survey Staff (1), the spiral part of the auger should be about 7 in. (18 cm) long, with the distances between flights about the same as the diameter (for example, 1.5 in.) of the auger. This facilitates measuring the depth of penetration of the tool. Variations on this design include the closed spiral auger and the Jamaica open spiral auger (2) (see Fig. 2(b) and (c)). The auger is welded onto a length of solid or tubular rod. The upper end of this rod is threaded, to accept a handle or extension rods. As many extensions are used as are required to reach the target sampling

<sup>5</sup> The boldface numbers in parentheses refer to the list of references at the end of the text.

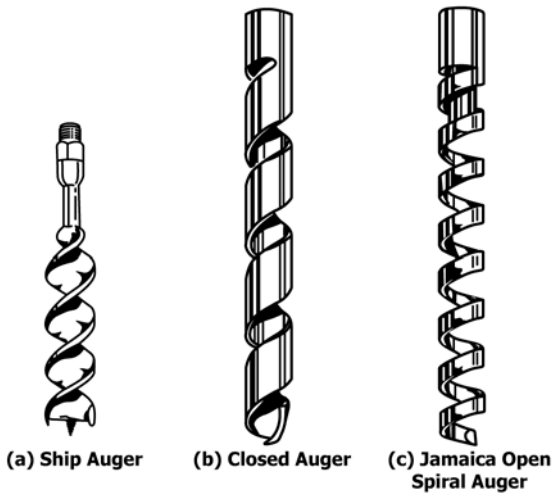

FIG. 2 Screw Type Augers

depth. The rod and the extensions are marked in even increments (for example, in 6-in. (15.24-cm) increments) above the base of the auger to aid in determining drilling depth. A wooden or metal handle fits into a tee-type coupling, screwed into the uppermost extension rod.

7.3.2 *Sampling Method*—For drilling, the auger is rotated manually. The operator may have to apply downward pressure to start and embed the auger; afterwards, the auger screws itself into the soil. The auger is advanced to its full length, and then pulled up and removed. Soil from the deepest interval penetrated by the auger is retained on the auger flights. A sample can be collected from the flights using a spatula. A foot pump operated hydraulic system has been developed to advance augers up to 4.5 in. (11.43 cm) in diameter. This larger diameter allows insertion of other sampling devices into the drill hole, once the auger is removed, if desired (3).<sup>6</sup>

7.3.3 *Comments*—Samples obtained with screw-type samplers are disturbed and are not truly core samples. Therefore, the samples are not suitable for tests requiring undisturbed samples, such as hydraulic conductivity tests. In addition, soil structures are disrupted and small scale lithologic features cannot be examined. Nevertheless, screw-type samplers are still suitable for use in collecting samples for the purpose of detecting contaminants. However, it is difficult to avoid transporting shallow soils downward when reentering a drill hole. When representative samples are desired from a discrete interval, the borehole must be made large enough to insert a sampler and extend it to the bottom of the borehole without touching the sides of the borehole. It is suggested that a larger diameter auger be used to advance and clear the borehole, then a smaller diameter auger sampler be used to obtain the sample. Screw-type augers work better in wet, cohesive soils than in dry, loose soils. Sampling in very dry (for example, powdery) soils may not be possible with these augers as soils will not be retained on the auger flights. Also, if the soil contains gravel or rock fragments larger than about one tenth of the hole diameter, drilling may not be possible (4).

#### 7.4 Barrel Augers:

7.4.1 *Description*—The barrel auger consists of a bit with cutting edges welded to a short tube or barrel within which the soil sample is retained, welded in turn to shanks. The shanks are welded to a threaded rod at the other end. Extension rods are attached as required to reach the target sampling depth. Extensions are marked in increments above the base of the tool. The uppermost extension rod contains a tee-type coupling for a handle. The auger is available in carbon steel and stainless steel with hardened steel cutting edges (5, 6).

7.4.2 *Sampling Method*—The auger is rotated to advance the barrel into the ground. The operator may have to apply downward pressure to keep the auger advancing. When the barrel is filled, the unit is withdrawn from the soil cavity and a sample may be collected from the barrel.

7.4.3 *Comments*—Barrel augers generally provide larger samples than screw-type augers. The augers can penetrate shallow clays, silts, and fine grained sands (7).<sup>6</sup> The augers do not work well in gravelly soils, caliche, or semi-lithified deposits. Samples obtained with barrel augers are disturbed and are not core samples. Therefore, the samples are not suitable for tests requiring undisturbed samples, such as hydraulic conductivity tests. Nevertheless, the samplers are still suitable for use in collecting samples for the purpose of detecting contaminants. Because the sample is retained inside the barrel, there is less of a chance of mixing it with soil from a shallower interval during insertion or withdrawal of the sampler. The following are five common barrel augers:

- 7.4.3.1 Post-hole augers (also called Iwan-type augers),
- 7.4.3.2 Dutch-type augers,
- 7.4.3.3 Regular or general purpose barrel augers,
- 7.4.3.4 Sand augers, and
- 7.4.3.5 Mud augers.

7.4.4 *Post-Hole Augers*—The most readily available barrel auger is the post-hole auger (also called the Iwan-type auger) (8). As shown in Fig. 3, the barrel consists of two-part cylindrical leaves rather than a complete cylinder and is slightly tapered toward the cutting bit. The taper and the cupped bit help to retain soils within the barrel. The barrel is

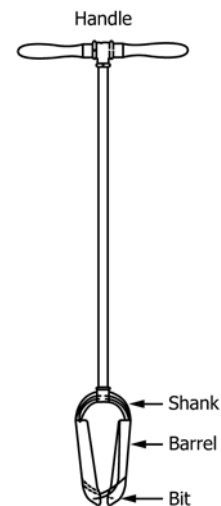

FIG. 3 Post-Hole Type Barrel Auger

<sup>6</sup> This reference is manufacturer's literature, and it has not been subjected to technical review.

available with a 3 to 12-in. (7.62 to 30.48-cm) diameter. There are two types of drilling systems, one has a single rod and handle, and the other has two handles. In stable, cohesive soils, the auger can be advanced up to 25 ft (7.62 m) (8).

7.4.5 *Dutch-Type Augers*—The Dutch-type auger (commercially developed by Eijkelkamp) is a smaller variation of the post-hole auger design. As shown in Fig. 4, the pointed bit is continuous with two, narrow part-cylindrical barrel segments, welded onto the shanks. The barrel generally has a 3 in. (7.62 cm) outside diameter. This tool is best suited for sampling wet, clayey soils.

7.4.6 *Regular or General Purpose Barrel Augers*—A version of the barrel auger commonly used by soil scientists and county agricultural agents is depicted in Fig. 5(a) and (b). As shown, the barrel is a complete cylinder. As with the post-hole auger, the cutting blades are cupped so that soil is loosened and forced into the barrel as the unit is rotated and pushed into the ground. Each filling of the barrel corresponds to a depth of penetration of 3 to 5 in. (7.62 to 12.70 cm) (1). The most popular barrel diameter is 3.5 in. (8.89 cm), but sizes ranging from 1.5 to 7 in. (3.81 to 17.78 cm) are available (6).<sup>6</sup> Plastic, stainless steel, PTFE (polytetrafluoroethylene), or aluminum liners can also be used (6).<sup>6</sup> Extension rods are available in 4 ft (1.22 m) lengths. The rods can be made from standard black pipe, from lightweight conduit or from seamless steel tubing. The extensions have evenly spaced marks to facilitate determining sample depth. The regular barrel auger is suitable for use in loam type soils.

7.4.7 *Sand Augers*—For dry, sandy soils it may be necessary to use a variation of the regular barrel auger that includes a specially-formed bit to retain the sample in the barrel (see Fig. 5(c)). Sand augers with 2, 3, or 4-in. (5.08, 7.62, or 10.16-cm) diameters are available (5).<sup>6</sup>

7.4.8 *Mud Augers*—Another variation on the regular barrel auger design is available for sampling wet, clayey soils. As shown in Fig. 5(d), the barrel is designed with open sides to facilitate extraction of samples. The bits are the same as those used on the regular barrel auger (6).<sup>6</sup> Mud augers with 2, 3, or 4-in. (5.08, 7.62, or 10.16-cm) diameters are available (5).<sup>6</sup>

7.5 *Tube-Type Samplers:*



FIG. 4 Dutch Type Auger

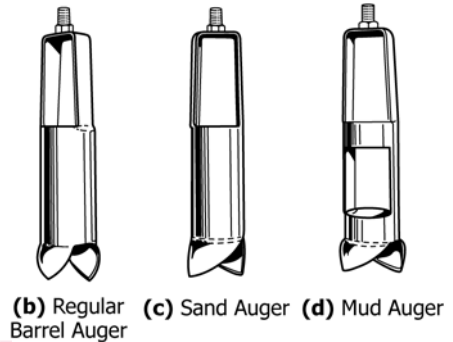
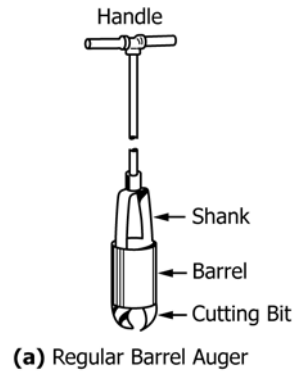

FIG. 5 Barrel Auger Variations and Soil Moisture

7.5.1 Tube-type samplers generally have proportionally smaller diameters and greater body lengths than those of barrel augers.

7.5.2 For sampling, these units are perched into the soil causing the tube to fill with material from the interval penetrated. The assembly is then pulled to the surface and a sample can be collected from the tube. Since the device is not rotated, a nearly undisturbed sample can be obtained. Commercial units are available with foot lever attachments, a hydraulic apparatus, or drop-hammers to aid in driving the sampler into the ground (5).<sup>6</sup> Vibratory heads have also been developed to advance tube-type samplers (9).<sup>6</sup>

7.5.3 These units are not as suitable for sampling in compacted, gravelly soils as are the barrel augers. They are preferred if an undisturbed sample is required. Commonly used varieties of the tube type samplers include:

- 7.5.3.1 Soil sampling tubes (also called Lord samplers),
- 7.5.3.2 Veihmeyer tubes (also called King tubes),
- 7.5.3.3 Thin-walled tube samplers (also called Shelby tubes),
- 7.5.3.4 Ring-lined barrel samplers, and
- 7.5.3.5 Piston samplers.

7.5.4 *Soil Sampling Tubes:*

7.5.4.1 *Description*—As depicted in Fig. 6, the soil sampling tube consists of a hardened cutting tip, a cut-away barrel, and an uppermost threaded segment. The cut-away barrel allows textural examination and easy removal of soil samples. Generally, the tube is constructed from high strength alloy steel (10).<sup>6</sup> The samplers are available with 6, 12, 15, 18, and 24-in. (15.24, 30.48, 38.10, 45.72, and 60.96-cm) lengths (5, 6). The tubes are available with 1.13 or 0.88-in. (2.87 or 2.22-cm)

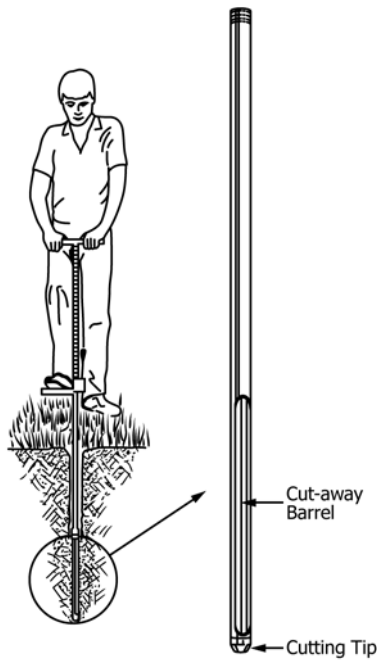

FIG. 6 Soil Sampling Tube

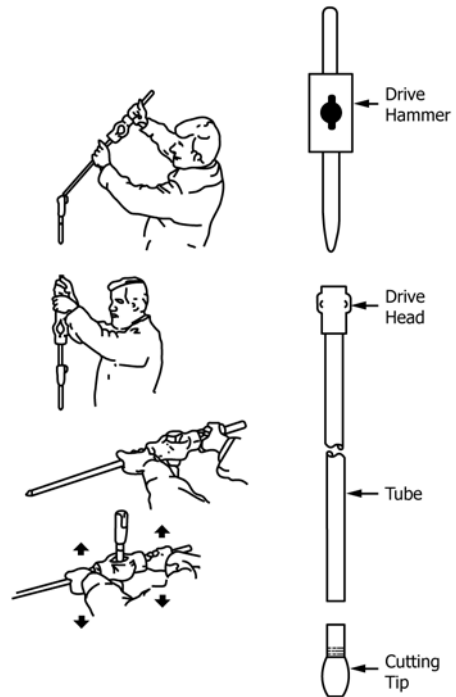

FIG. 7 Veihmeyer Tube

outside diameter. Two modified versions of the tip are available, for sampling in wet or dry soils. The sampling tube is attached to extension rods to attain the target sampling depth. A cross-handle is attached to the uppermost rod. Extension rods are made of lightweight, durable metal. They are available in a variety of lengths depending on the manufacturer. Markings on the extensions and the sampler facilitate determining sample depths.

**7.5.4.2 Sampling Method**—The sampler is pushed into the ground by leaning on the unit’s handle. Once the sampler has reached the bottom of the sampling interval, it is twisted to break soil continuity at the tip. Depending on the type of cutting edge, the tube sampler may obtain samples varying in diameter from 0.69 to 0.75 in. (1.75 to 1.91 cm).

**7.5.4.3 Comments**—The soil sampling tube works best in soft, clayey, cohesive soils. If the soil contains cobbles or rock fragments larger than about one-half the cutting tip diameter, satisfactory sampling may not be possible. If the soil is cohesionless, it will not be retained in the tube. With time, the cutting tip will be damaged and worn dull. Most units are designed so that this part can be replaced.

**7.5.5 Veihmeyer Tubes:**

**7.5.5.1 Description**—The Veihmeyer tube is a long, complete cylinder. As shown in Fig. 6, this unit consists of a bevelled tip, that is threaded into the lower end of the tube, and a drive head threaded onto the upper end of the tube. The sampler is constructed of hardened steel. The tube is generally marked in even increments (for example, 1 ft or 0.30 m). These samplers are available in 4 to 16-ft (1.22 to 4.88-m) lengths with a 0.75-in. (1.91-cm) inside diameter.

**7.5.5.2 Sampling Method**—The lower guide rod of the drop hammer is slipped into the upper tube, through the drive head (see Fig. 7). The hammer is used to pound the sampler into the ground. The sampler is then retrieved by pulling or jerking up

on the hammer to force the sampler out of the soil cavity. Samples are extruded by forcing a rod through the tube.

**7.5.5.3 Comments**—Prior to sampling, the inside of the tube is sometimes coated with a lubricant to facilitate extrusion. However, the types of analyses to be performed on the samples should be considered to determine if the presence of lubricant will cause interference. Because the Veihmeyer sampler is a solid-walled tube and is fitted with a drop hammer, it can generally be used in more resistant soils than the soil sampling tube.

**7.5.6 Thin-Walled Tube Samplers:**

**7.5.6.1 Description**—Thin-walled tube (Shelby Tube) samplers are readily available with 2, 3, and 5-in. (5.08, 7.62, and 12.70-cm) outside diameters and are commonly 30 in. (76.20 cm) long. The 3 by 30-in. (7.62 by 76.20-cm) outside diameter long sampler is most common. The advancing end of the sampler is rolled inwardly and has a cutting edge with a smaller diameter than the tube inside diameter. The cutting edge inside diameter reduction, defined as a “clearance ratio,” is usually in the range of 0.0050 to 0.0150 or 0.50 to 1.50 % (Refer to Practice D1587). The sampler tube is usually connected with set screws to a sampler head that in turn is threaded to connect with extension rods. Plastic and PTFE sealing caps for use after sampling are readily available for the 2, 3, and 5-in. (5.08, 7.62, and 12.70-cm) diameter tubes (refer to Practices D4220). Shelby tubes are commonly available in carbon steel but can be manufactured from other metal (see Fig. 8).

**7.5.6.2 Sampling Method**—The Shelby tube is pushed into soil by hand, with a jack-like system or with a hydraulic piston. The sample recovered is often less than the distance pushed, that is, the recovery ratio is less than 1.0. The recovery ratio is less than 1.0 because of soil compaction during sampling, and

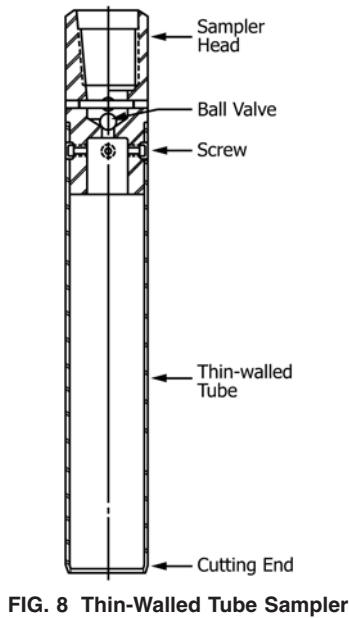

FIG. 8 Thin-Walled Tube Sampler

because friction between soil and the inner tube walls becomes greater than the shear strength of the soil in front of the tube. Consequently, soil in front of the advancing end of the tube is displaced laterally rather than entering the tube (11). In general, shorter tubes provide less-disturbed samples than longer tubes. Samples are extruded from the Shelby tube with a hydraulic ram. As with all sampling devices, the most disturbed portion of the sample in contact with the tube is considered unrepresentative. Wilson et al. (12) developed a paring device to remove this outer layer of the core during extrusion.

7.5.6.3 *Comments*—Shelby tubes are best used in clays, silts, and fine-grained sands. If the soils are cohesionless, they may not be retained in the tube. If firm to very hard soils are encountered, driving (hammering) the sampler may be required. However, this should be avoided as the tube may buckle under the drive stress.

7.5.7 *Ring-Lined Barrel Samplers :*

7.5.7.1 *Description*—As described in Practice D3550, the ring-lined barrel sampler consists of a one piece barrel or two split barrel halves, a drive shoe, rings, and a sampler head (see Fig. 9). The rings, that are usually brass, fit snugly inside the barrel and are designed to be directly inserted into geotechnical testing apparatuses when removed from the barrel. Most samplers are designed to hold at least two rings. The barrel is commonly 3.5 in. (8.89 cm) inside diameter and 3.94 to 5.91 in. (10 to 15 cm) long (5).<sup>6</sup> With these lengths, the barrel can be fitted with a variety of liners ranging in length from 1 to 2.36 in. (2.54 to 6 cm).

7.5.7.2 *Sampling Method*—The ring-lined barrel sampler can be driven or pushed into soil. Once retrieved, the sampler is disassembled, and the sample-filled rings are removed. The rings are usually removed as one unit and placed into a capped container. Alternately, the individual soil-filled rings can be capped with plastic or PTFE and then sealed with wax or adhesive tape (refer to Practices D4220).

7.5.7.3 *Comments*—Because barrel samplers are more rigid than thin-walled tubes, they can be driven into hard soils and

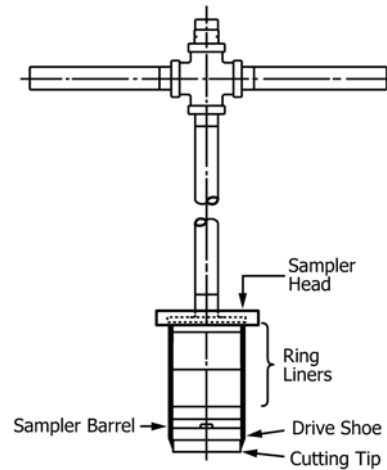

FIG. 9 Hand Operated Ring-Lined Barrel Sampler

soils containing sands and gravels that might damage thin-walled tubes. The sampler provides samples in rings which can be handled without further disturbance of the soil. Because of this, these devices are most often used when geotechnical or chemical analyses are to be performed.

7.5.8 *Piston Samplers:*

7.5.8.1 *Description*—Locally saturated (for example, by perched ground water), or cohesionless soils, and very soft soils or sludges may not be retained in most samplers, even when fitted with retainer baskets or flap valves. Piston samplers can be used in these situations. The sampler consists of a sampling tube, extension pipe attached to the tube, an internal piston, and rods connected to the piston and running through the extension pipe (see Fig. 10). These samplers are often built,

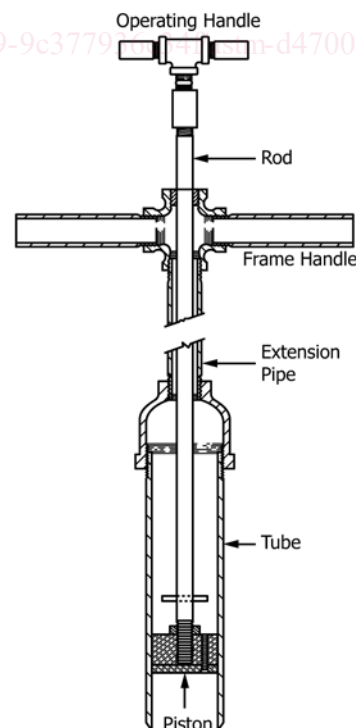

FIG. 10 Hand Operated Piston Sampler