



Designation: C 359 – 06

## Standard Test Method for Early Stiffening of Hydraulic Cement (Mortar Method)<sup>1</sup>

This standard is issued under the fixed designation C 359; the number immediately following the designation indicates the year of original adoption or, in the case of revision, the year of last revision. A number in parentheses indicates the year of last approval. A superscript epsilon ( $\epsilon$ ) indicates an editorial change since the last revision or reapproval.

### 1. Scope\*

1.1 This test method covers the determination of early stiffening in hydraulic-cement mortar.

1.2 The values stated in SI units are the standard. The values in parentheses are for information only.

1.3 *This standard does not purport to address all of the safety concerns, if any, associated with its use. It is the responsibility of the user of this standard to establish appropriate safety and health practices and determine the applicability of regulatory limitations prior to use. (Warning—Fresh hydraulic cementitious mixtures are caustic and may cause chemical burns to skin and tissue upon prolonged exposure. The use of gloves, protective clothing, and eye protection is recommended. Wash contact area with copious amounts of water after contact. Wash eyes for a minimum of 15 min. Avoid exposure of the body to clothing saturated with the liquid phase of the unhardened material. Remove contaminated clothing immediately after exposure.)<sup>2</sup>*

1.4 The text of this standard references notes and footnotes which provide explanatory material. These notes and footnotes (excluding those in tables and figures) shall not be considered as requirements of the standard.

### 2. Referenced Documents

#### 2.1 ASTM Standards:<sup>3</sup>

C 183 Practice for Sampling and the Amount of Testing of Hydraulic Cement

C 185 Test Method for Air Content of Hydraulic Cement Mortar

C 187 Test Method for Normal Consistency of Hydraulic Cement

C 305 Practice for Mechanical Mixing of Hydraulic Cement Pastes and Mortars of Plastic Consistency

C 670 Practice for Preparing Precision and Bias Statements for Test Methods for Construction Materials

C 778 Specification for Standard Sand

C 1005 Specification for Reference Masses and Devices for Determining Mass and Volume for Use in the Physical Testing of Hydraulic Cements

D 1193 Specification for Reagent Water

E 1 Specification for ASTM Liquid-in-Glass Thermometers

### 3. Terminology

#### 3.1 Definitions:

3.1.1 *early stiffening, n*—the early development of stiffness in the working characteristics of a hydraulic-cement paste, mortar, or concrete; varieties include false set and flash set.

3.1.2 *false set, n*—the early development of stiffness in the working characteristics of a hydraulic-cement paste, mortar, or concrete without the evolution of much heat, which stiffness can be dispelled and plasticity regained by further mixing without addition of water; also known as “grab set,” “premature stiffening,” “hesitation set,” and “rubber set.”

3.1.3 *flash set, n*—the early development of stiffness in the working characteristics of a hydraulic-cement paste, mortar, or concrete, usually with the evolution of considerable heat, which stiffness cannot be dispelled nor can the plasticity be regained by further mixing without addition of water; also known as “quick set.”

### 4. Summary of Test Method

4.1 A mortar is prepared with the cement to be tested, using specified quantities of cement, standard sand, and an amount of water that will produce a mortar with an initial penetration of  $46 \pm 3$  mm, using the modified Vicat apparatus. Measurements of penetration are made at stipulated intervals after the beginning of the mixing procedure. Upon completion of the first series of penetration measurements, the mortar is returned to the mixer to be remixed. Following the remix procedure, an

<sup>1</sup> This test method is under the jurisdiction of ASTM Committee C01 on Cement and is the direct responsibility of Subcommittee C01.30 on Time of Set.

Current edition approved July 1, 2006. Published August 2006. Originally approved in 1955. Last previous edition approved in 2005 as C 359 – 05.

<sup>2</sup> Section on Safety, Manual of Cement Testing, *Annual Book of ASTM Standards*, Vol 04.01.

<sup>3</sup> For referenced ASTM standards, visit the ASTM website, [www.astm.org](http://www.astm.org), or contact ASTM Customer Service at [service@astm.org](mailto:service@astm.org). For *Annual Book of ASTM Standards* volume information, refer to the standard's Document Summary page on the ASTM website.

additional penetration, termed the remix penetration, is determined. The report is a tabulation of the penetration measurements and the amount of mixing water used.

## 5. Significance and Use

5.1 The purpose of this test method is to determine the degree to which a cement mortar develops early stiffening. It is intended for use by those interested in methods for determining the potential early stiffening of hydraulic cement.

5.2 When used for estimating the relative tendency of a cement to manifest early stiffening, a judgment may be made by comparing the behavior in the penetration series (see 10.4.1 and 10.4.2) and the remix procedure (see 10.4.3) to differentiate a relatively less serious and less persistent tendency to early stiffening (false set) from one that is more persistent and, consequently, more serious (flash set).

5.3 Severe false setting in a cement may cause difficulty from a placing and handling standpoint, but it is not likely to cause difficulties where concrete is mixed for a longer time than usual, as usually occurs in transit mixing, or where it is remixed prior to placing or transporting, in concrete pumping operations. It is most likely noticed where concrete is mixed for a short period of time in stationary mixers and transported to the forms in non-agitating equipment, as on some paving jobs, and when concrete is made in an on-site batch plant.

5.4 Cements with severe false setting usually require slightly more mixing water to produce the same consistency, which may result in slightly lower strengths and increased drying shrinkage.

5.5 Early stiffening resulting from false set is not likely to cause a cement to fail the applicable time of setting requirement.

5.6 Early stiffening resulting from flash set, depending on severity, can cause a cement to fail the applicable time of setting requirement.

## 6. Apparatus

6.1 *Vicat Apparatus*, conforming to the requirements of Fig. 1 in Test Method C 187, with the following modifications:

6.1.1 The 1-mm needle shall be replaced by a mass, such that the total mass of the 10-mm plunger, indicator, and added mass shall be  $400 \pm 0.5$  g.

6.2 *Spoon*, conforming to the requirements of Test Method C 185.

6.3 *Mixer, Bowl, Paddle, and Scraper*, conforming to the requirements of Practice C 305.

6.4 *Glass Graduates*, 200 or 250 mL capacity, conforming to the requirements of Specification C 1005.

6.5 *Masses and Mass Determining Devices*, conforming to the requirements of Specification C 1005. The devices for determining mass shall be evaluated for precision and bias at a total load of 1000 g.

6.6 *Thermometer*, ASTM No. 1C or 1F, conforming to the requirements of Specification E 1.

6.7 *Flat Trowel*, having a sharpened straight-edged steel blade 100 to 150 mm in length.

6.8 *Clock Timer*, having a readability to the nearest second.

6.9 *Containers*, approximately 50 by 50 by 150 mm (2 by 2 by 6 in.) inside dimensions (Fig. 1). These containers, which

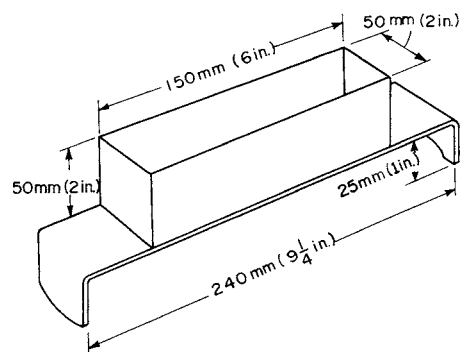

**FIG. 1 Container for Early Stiffening Tests**

may be made of any suitable materials such as sheet metal or plastic, shall be rigid, watertight, and at least 50 mm (2 in.) deep.

## 7. Reagents and Materials

7.1 *Standard Sand, 20-30 and Graded*, conforming to the requirements of Specification C 778.

7.2 *Mixing Water*—Potable water is satisfactory for routine tests. For all referee and cooperative tests, reagent water conforming to the requirements of Specification D 1193 for Type III or Type IV grades of reagent water shall be used.

## 8. Sampling

8.1 When the test is part of acceptance testing, sample the cement in accordance with Practice C 183.

## 9. Conditioning

9.1 Maintain the temperature of the room, dry materials, paddle, bowl, and containers at  $23.0 \pm 3.0$  °C.

9.2 The relative humidity of the laboratory shall not be less than 50 %.

## 10. Procedure

10.1 *Batch*—Mix at one time 600 g of cement, 300 g of graded standard sand, 300 g of 20-30 standard sand, and an amount of water that produces a mortar with an initial penetration of  $46 \pm 3$  mm.

10.2 *Mixing of Mortar*—Mix in the mechanical mixer as follows:

10.2.1 Place the sand and cement in the dry bowl, and mix the dry materials for a few seconds with the spoon.

10.2.2 Place the bowl in the mixer, set the paddle in place, and mix the dry materials for 10 s at a slow speed ( $140 \pm 5$  r/min).

10.2.3 With the mixer operating at a slow speed ( $140 \pm 5$  r/min), add the entire quantity of mixing water within 5 s. Stop the mixer, quickly change to a medium speed ( $285 \pm 10$  r/min), and continue the mixing for 1 min, timing from the first addition of water.

10.2.4 Stop the mixer, scrape the sides of the mixing bowl with the rubber scraper, and quickly place the thermometer in the mortar. Allow it to stand undisturbed for the remainder of a 45-s interval from the time of stopping the mixer.