



Designation: D5781 – 95(Reapproved 2006)

# Standard Guide for Use of Dual-Wall Reverse-Circulation Drilling for Geoenvironmental Exploration and the Installation of Subsurface Water-Quality Monitoring Devices<sup>1</sup>

This standard is issued under the fixed designation D5781; the number immediately following the designation indicates the year of original adoption or, in the case of revision, the year of last revision. A number in parentheses indicates the year of last reapproval. A superscript epsilon ( $\epsilon$ ) indicates an editorial change since the last revision or reapproval.

## 1. Scope

1.1 This guide covers how dual-wall reverse-circulation drilling may be used for geoenvironmental exploration and installation of subsurface water-quality monitoring devices.

NOTE 1—The term *reverse circulation* with respect to dual-wall drilling in this guide indicates that the circulating fluid is forced down the annular space between the double-wall drill pipe and transports soil and rock particles to the surface through the inner pipe.

NOTE 2—This guide does not include considerations for geotechnical site characterizations that are addressed in a separate guide.

1.2 Dual-wall reverse-circulation for geoenvironmental exploration and monitoring-device installations will often involve safety planning, administration, and documentation. This guide does not purport to specifically address exploration and site safety.

1.3 The values stated in SI units are to be regarded as standard. The values given in parentheses are for information only.

1.4 *This standard does not purport to address all of the safety concerns, if any, associated with its use. It is the responsibility of the user of this standard to establish appropriate safety and health practices and determine the applicability of regulatory limitations prior to use.*

1.5 *This guide offers an organized collection of information or a series of options and does not recommend a specific course of action. This document cannot replace education or experience and should be used in conjunction with professional judgment. Not all aspects of this guide may be applicable in all circumstances. This ASTM standard is not intended to represent or replace the standard of care by which the adequacy of a given professional service must be judged, nor should this document be applied without consideration of a project's many unique aspects. The word "Standard" in the title of this*

*document means only that the document has been approved through the ASTM consensus process.*

## 2. Referenced Documents

### 2.1 ASTM Standards:<sup>2</sup>

D653 Terminology Relating to Soil, Rock, and Contained Fluids

D1452 Practice for Soil Exploration and Sampling by Auger Borings

D1586 Test Method for Penetration Test (SPT) and Split-Barrel Sampling of Soils

D1587 Practice for Thin-Walled Tube Sampling of Soils for Geotechnical Purposes

D2487 Practice for Classification of Soils for Engineering Purposes (Unified Soil Classification System)

D3550 Practice for Thick Wall, Ring-Lined, Split Barrel, Drive Sampling of Soils

D4428/D4428M Test Methods for Crosshole Seismic Testing

D5088 Practice for Decontamination of Field Equipment Used at Waste Sites

D5092 Practice for Design and Installation of Ground Water Monitoring Wells

D5099 Test Methods for Rubber—Measurement of Processing Properties Using Capillary Rheometry

D5254 Practice for Minimum Set of Data Elements to Identify a Ground-Water Site

D5434 Guide for Field Logging of Subsurface Explorations of Soil and Rock

## 3. Terminology

### 3.1 Definitions:

3.1.1 Terminology used within this guide is in accordance with Terminology D653. Definitions of additional terms may be found in Terminology D653.

### 3.2 Definitions of Terms Specific to This Standard:

<sup>1</sup> This guide is under the jurisdiction of ASTM Committee D18 on Soil and Rock and is the direct responsibility of Subcommittee D18.21 on Groundwater and Vadose Zone Investigations.

Current edition approved July 1, 2006. Published August 2006. Originally approved in 1995. Last previous edition approved in 2000 as D5781 – 95 (2000). DOI: 10.1520/D5781-95R06.

<sup>2</sup> For referenced ASTM standards, visit the ASTM website, www.astm.org, or contact ASTM Customer Service at service@astm.org. For *Annual Book of ASTM Standards* volume information, refer to the standard's Document Summary page on the ASTM website.

3.2.1 *bentonite*—common name for drilling-fluid additives and well-construction products consisting mostly of naturally-occurring montmorillonite. Some bentonite products have chemical additives that may affect water-quality analyses.

3.2.2 *bentonite granules and chips*—irregularly-shaped particles of bentonite (free from additives) that have been dried and separated into a specific size range.

3.2.3 *bentonite pellets*—roughly spherical- or disc-shaped units of compressed bentonite powder (some pellet manufacturers coat the bentonite with chemicals that may affect the water quality analysis).

3.2.4 *coefficient of uniformity*— $C_u(D)$ , the ratio  $D_{60}/D_{10}$ , where  $D_{60}$  is the particle diameter corresponding to 60 % finer on the cumulative particle-size distribution curve, and  $D_{10}$  is the particle diameter corresponding to 10 % finer on the cumulative particle-size distribution curve.

3.2.5 *drawworks*—a power-driven winch, or several winches, usually equipped with a clutch and brake system(s) for hoisting or lowering a drilling string.

3.2.6 *drill hole*—a cylindrical hole advanced into the subsurface by mechanical means. Also known as a borehole or boring.

3.2.7 *filter pack*—also known as a gravel pack or a primary filter pack in the practice of monitoring-well installations. The gravel pack is usually granular material, having selected grain size characteristics, that is placed between a monitoring device and the borehole wall. The basic purpose of the filter pack or gravel envelope is to act as: (1) a non-clogging filter when the aquifer is not suited to natural development or, (2) act as a formation stabilizer when the aquifer is suitable for natural development.

3.2.7.1 *Discussion*—Under most circumstances a clean, quartz sand or gravel should be used. In some cases a pre-packed screen may be used.

3.2.8 *hoisting line*—or drilling line, is wire rope used on the drawworks to hoist and lower the drill string.

3.2.9 *in-situ testing devices*—sensors or probes, used for obtaining mechanical or chemical-test data, that are typically pushed, rotated or driven below the bottom of a borehole following completion of an increment of drilling. However, some in-situ testing devices (such as electronic pressure transducers, gas-lift samplers, tensiometers, and etc.) may require lowering and setting of the device(s) in a pre-existing borehole by means of a suspension line or a string of lowering rods or pipe. Centralizers may be required to correctly position the device(s) in the borehole.

3.2.10 *intermittent-sampling devices*—usually barrel-type samplers that are driven or pushed below the bottom of a borehole following completion of an increment of drilling. The user is referred to the following ASTM Standards relating to suggested sampling methods and procedures: Practice **D1452**, Test Method **D1586**, Practice **D3550**, and Practice **D1587**.

3.2.11 *mast*—or derrick, on a drilling rig is used for supporting the crown block, top drive, pulldown chains, hoisting lines, etc. It must be constructed to safely carry the expected

loads encountered in drilling and completion of wells of the diameter and depth for which the rig manufacturer specifies the equipment.

3.2.11.1 *Discussion*—To allow for contingencies, it is recommended that the rated capacity of the mast should be at least twice the anticipated weight load or normal pulling load.

3.2.12 *piezometer*—an instrument for measuring pressure head.

3.2.13 *subsurface water-quality monitoring device*—an instrument placed below ground surface to obtain a sample for analysis of the chemical, biological or radiological characteristics of subsurface-pore water or to make in-situ measurements.

## 4. Significance and Use

4.1 Dual-wall reverse-circulation drilling can be used in support of geoenvironmental exploration and for installation of subsurface water-quality monitoring devices in unconsolidated and consolidated materials. Dual-wall reverse-circulation drilling methods permit the collection of water-quality samples at any depth(s), allows the setting of temporary casing during drilling, cuttings samples can be taken continuously as circulation is maintained at all times during drilling. Other advantages of the dual-wall reverse-circulation drilling method include: (1) the capability of drilling without the introduction of any drilling fluid(s) to the subsurface; (2) maintenance of hole stability for sampling purposes and monitor-well installation/construction in poorly-indurated to unconsolidated materials.

NOTE 3—The user of dual-wall reverse-circulation drilling for geoenvironmental exploration and monitoring-device installations should be cognizant of both the physical (temperature and airborne particles) and chemical (compressor lubricants and possible fluid additives) qualities of compressed air that may be used as the circulating medium.

4.2 The application of dual-wall reverse-circulation drilling to geoenvironmental exploration may involve soil or rock sampling, or in-situ soil, rock, or pore-fluid testing.

NOTE 4—The user may install a monitoring device within the same borehole wherein sampling, in-situ or pore-fluid testing, or coring was performed.

4.3 The subsurface water-quality monitoring devices that are addressed in this guide consist generally of a screened- or porous-intake device and riser pipe(s) that are usually installed with a filter pack to enhance the longevity of the intake unit, and with isolation seals and low-permeability backfill to deter the movement of fluids or infiltration of surface water between hydrologic units penetrated by the borehole (see Practice **D5092**). Inasmuch as a piezometer is primarily a device used for measuring subsurface hydraulic heads, the conversion of a piezometer to a water-quality monitoring device should be made only after consideration of the overall quality and integrity of the installation to include the quality of materials that will contact sampled water or gas.

NOTE 5—Both water-quality monitoring devices and piezometers should have adequate casing seals, annular isolation seals and backfills to deter communication of contaminants between hydrologic units.

## 5. Apparatus

5.1 The basic mechanical components of dual-wall reverse-circulation drilling systems include dual-wall pipe, drill compressor and filter(s), water pump, discharge hose, cleaning device (cyclone separator). The dual-wall drill advanced by the percussive action of an above-ground pile hammer or by rotation from a rotary-drive unit.

NOTE 6—Other methods, such as vibratory equipment sonic resonators, may be used to apply the energy required to advance the dual-wall drill pipe.

5.1.1 *dual-wall drill pipe*, consists of an inner pipe secured concentrically within an outer pipe. Inner-pipe connections utilize pin and box components with seals. Outer-pipe connections are flush threaded.

NOTE 7—Drill pipes usually require lubricants on the threads to allow easy unthreading (breaking) of the connecting joints. Some lubricants have organic or metallic constituents, or both, that could be interpreted as contaminants if detected in a sample. Various lubricants are available that have components of known chemistry. The effect of pipe-thread lubricants on chemical analyses of samples should be considered and documented when using dual-wall reverse-circulation drilling. The same consideration and documentation should be given to lubricants used with water swivels, hoisting swivels, or other devices used near the drilling axis.

5.1.2 The drill bit is attached to the bottom of the dual-wall drill pipe and provides the soil- or rock-cutting capability. Drill bit types include tricone roller, down-the-hole (DTH) hammer or, open faced. Drill bit selection should be based upon the character of the soils or rocks penetrated. DTH lubricants should be documented.

NOTE 8—In North America, the sizes of casings bits, drill rods and core barrels are standardized by American Petroleum Institute (API) and the Diamond Core Drill Manufacturers Association (DCDMA). Refer to the DCDMA technical manual and to published materials of API for available sizes and capacities of drilling tools equipment.

5.1.3 The air compressor and filter(s) should provide an adequate volume of air for removal of cuttings without significant contamination generated at the bit. Air requirements will vary depending upon the size and configuration of the drill pipe used, and the character of the soil and rock penetrated. The air-flow rates are usually based on maintaining an upflow air velocity of about 1400 m/min (4200 ft/min).

NOTE 9—The quality of compressed air entering the borehole and the quality of air discharged from the borehole and air-cleaning devices must be considered. If not adequately filtered, the air produced by most oil-lubricated air compressors inherently introduces a significant quantity of oil into the circulation system. High-efficiency, in-line, air filters are usually required to prevent significant contamination of the borehole. Air-quality monitoring may be required and, if performed, results should be documented.

5.1.4 A water pump may be used to inject water into the circulating air stream or may be used to inject water without air as the circulating fluid. If water is injected, the approximate volumes and locations should be reported.

5.1.5 A discharge hose conducts discharged drill cuttings and circulation-return air away from the borehole.

5.1.6 *Air-Cleaning Device System*, generally called a cyclone separator, separates cuttings from the air returning from the borehole.

NOTE 10—A properly-sized cyclone separator can remove practically all of the cuttings from the return air. A small quantity of fine particles, however, are usually discharged to the atmosphere with the “cleaned” air. Some air-cleaning devices consist of a cyclone separator alone. In special cases, the cyclone separator can be combined with a HEPA (high-efficiency particulate air) filter for removing dust particles that might be radioactive. In other special situations, the cyclone separator may be used in conjunction with a charcoal-filtering arrangement for removal of organic volatiles. Samples of drill cuttings can be collected for analyses of materials penetrated. If samples are obtained, the depth(s) and interval(s) of sample collection should be documented.

5.1.7 *Pile Hammer*, is commonly used to advance dual-wall drill pipe. The percussive force of the pile hammer is applied only to the outer pipe.

5.1.8 *Rotary-Drive Unit*, may be used to advance dual-wall drill pipe by rotation. Torque generated from a rotary-drive unit is applied only to the outer pipe.

## 6. Drilling Procedures

6.1 *Dual-Wall Percussion-Hammer Method* (see Fig. 1):

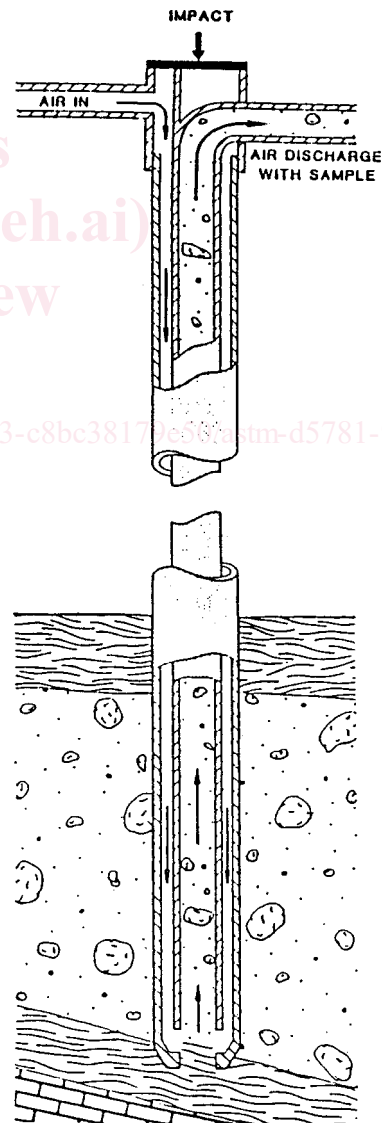

FIG. 1 Drilling with the Dual Wall Percussion Hammer Method

6.1.1 As a prelude to and throughout the drilling process stabilize the drill rig, and raise the drill-rig mast and position the cyclone separator. If air-monitoring operations are performed the prevalent wind direction relative to the exhaust from the drill rig should be considered. Also, the location of the cyclone relative to the rig exhaust should be considered since air-quality monitoring will be performed at the cyclone separator discharge point.

6.1.2 Thread an open-faced bit to the drill pipe.

6.1.3 Force compressed air down the annular space formed between the inner pipes and outer pipes as the percussive action of the pile hammer advances the dual-wall drill pipe. Conduct drill cuttings to the surface through the inner pipe.

6.1.4 Continue air circulation and the percussive action until drilling progresses to a depth where sampling or in-situ testing is to be performed or until the length of the drill-pipe section limits further penetration.

NOTE 11—At a minimum, the following information should be documented: number of impacts or driving conditions (i.e. hard, soft, rapid/slow penetration rate), air pressures, water added, volume of cuttings or cuttings return, air quality data, samples taken, water losses, heaving, and any observed unusual occurrences. Drilling rates depend on many factors such as the density or stiffness of unconsolidated material and the existence of cobbles or boulders, the hardness and/or durability of the rock, the swelling activity of clays or shales encountered in the borehole and the erosiveness of the borehole wall. Drilling rates can vary from a few mm (less than an in./min) to about 1 m (3 ft)/min, depending on subsurface conditions. Other factors influencing drilling rates include the weight of the drill string. These data as well as any other drilling-rate information should be recorded.

6.1.5 The percussive action is then stopped. Maintain air circulation, however, for a short time until the drill cuttings are removed from the inner pipe.

6.1.6 Increase drilling depth by attaching an additional section of dual-wall drill pipe to the top of the previously-advanced section of dual-wall drill pipe.

6.1.7 Sampling or in-situ testing can be performed at any depth. Insert the sampling or in-situ testing device through the open inner pipe and open-faced bit and lower to the material at the bottom of the borehole.

NOTE 12—Sampling and testing devices should be decontaminated according to Practices D5088 prior to testing.

6.2 “Triple-Wall” Percussion Method (see Fig. 2):

6.2.1 As a prelude to and throughout the drilling process, stabilize the drill rig, and raise the drill rig mast with the cyclone separator positioned. If air-monitoring operations are performed, the prevalent wind direction relative to the exhaust from the drill rig should be considered. Also, the location of the cyclone relative to the rig exhaust should be considered since air-quality monitoring will be performed at the cyclone separator discharge point.

6.2.2 Place a single-wall, flush-threaded pipe over the outside of the dual-wall drill pipe, thus making a triple-wall drilling assembly.

6.2.3 Advance the triple-wall drilling assembly as a single unit by the percussive action of the pile hammer as described in 6.1. Drill cuttings are removed only through the dual-wall part of this drill-pipe assembly.

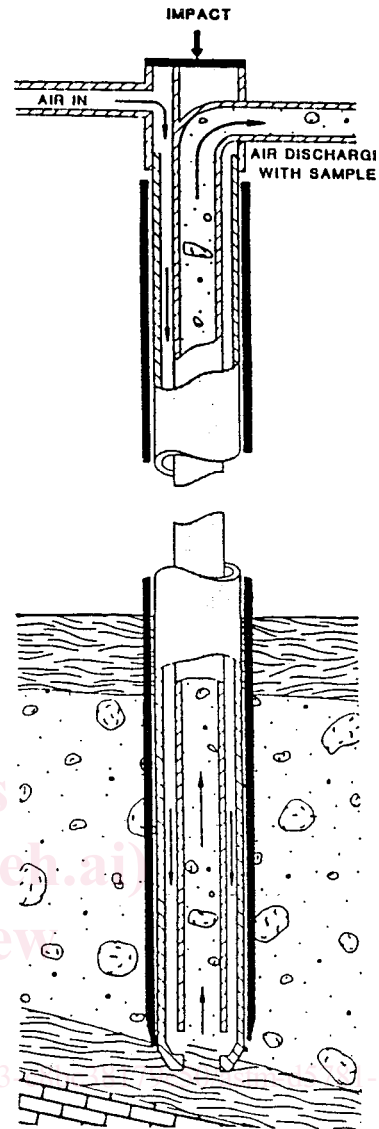

FIG. 2 Drilling with the “Triple Wall” Percussion Hammer Method

6.2.4 Perform sampling or in-situ testing at any depth. Insert the sampling or in-situ testing device through the open inner pipe and open-faced bit and thence into the material at the bottom of the borehole.

NOTE 13—Sampling and testing devices should be decontaminated according to Practices D5088 prior to testing.

6.3 Dual-Wall Rotary Method (see Fig. 3):

6.3.1 As a prelude to and throughout the drilling process first stabilize the drill rig, raise rig mast, and position the cyclone separator. If air-monitoring operations are performed, consider the prevalent wind direction relative to the exhaust from the drill rig. Also, consider the location of the cyclone separator relative to the rig exhaust since air-quality monitoring may be performed at the cyclone separator discharge point.

6.3.2 Thread an open-faced multicone roller bit or DTH-hammer bit (using appropriate crossover sub) to the drill pipe.

6.3.3 Force compressed air down the annular space formed between the inner pipes and outer pipes as the rotation from the top-head drive unit advances the dual-wall drill pipe. Conduct